

SMART FORTWO COUPÉ OWNER'S MANUAL



Table of Contents

[Table of Contents](#)

[Protection of the environment](#)

[smart genuine parts](#)

[Warranty for the smart Audio-System and smart Media-System](#)

[Vehicle equipment](#)

[Operating safety](#)

[QR codes for rescue card](#)

[Data stored in the vehicle](#)

[Copyright information](#)

Cockpit

Multifunction steering wheel

Centre console with drawer

Overhead control panel

Door control panel

Displays shown in the instrument cluster and the display

Occupant safety

Children in the vehicle

Pets in the vehicle

Driving safely

Opening the door

Correct driver's seat position

Adjusting the seats

Adjusting the steering wheel

Adjusting the mirrors

Running-in a new vehicle

Starting the engine

Pulling away

Automatic start/stop system

Manual transmission

Automatic transmission

Using the turn signals

Driving economically

Braking correctly

Driving on wet roads

Winter driving

Lane Keeping Assist

Cruise control and limiter

Refuelling

Switching on the lighting

Adjusting the lighting

Using the interior lighting

Using the windscreen wipers

Folding the sun visor to the side

Locking and unlocking the doors from the inside

Understanding the reversing function

Opening and closing the windows

Using the soft top (smart fortwo cabrio)

Operating the climate control system

Switching the seat heating on and off

Using the accessories

Parking

Using the parking aid

Using the reversing camera

Locking the vehicle

Priming and deactivating the anti-theft alarm system

Overview of the on-board computer

Calling up displays

Setting values

Operating and setting the smart Audio-System

Listening to the radio

Using a mobile phone

Operating external data storage media

Operating and setting up the smart Media-System

Listening to the radio

Using a mobile phone

Connecting and operating external data storage media

Viewing images

Video playback

Using the navigation system

Managing apps

Stowing small objects

Stowing luggage and large objects

Using the boot separator

Useful information

Removing/fitting the subwoofer

Opening and closing the engine compartment cover

Opening and closing the service cover

Checking service products and topping up

Checking wheels and tyres

Changing a wheel

Using the tyre pressure monitor

Checking the tyre pressures

Using winter tyres

Using snow chains

Changing the window wiper blades

Cleaning the vehicle

Observing service due dates

Parking up the vehicle

Securing the vehicle in the event of an accident or a breakdown

Removing the first-aid kit

Removing the fire extinguisher

Removing the vehicle tool tray

Sealing tyres using the TIREFIT kit

Jump-starting and charging the battery

Towing and tow-starting the vehicle

Manually releasing the selector lever lock

Replacing the bulbs

Changing fuses

Replacing the key battery

Opening a door with the emergency release

Locking the doors in an emergency

Notes on display messages

Locking and unlocking

Visibility, occupants, airbags

Engine, brakes, transmission

Driving safety systems

Driver assistance systems

Battery, lights, heating

smart Audio-System and smart Media-System

Obtaining technical data

Reading out vehicle data

Service products

Bulb types

Fuse allocation

Radio type approvals for the tyre pressure monitors

Retrofitting two-way radios and mobile phones (RF transmitters)

Other ManualsLib Projects



>> Owner's Manual

smart fortwo coupé and smart fortwo cabrio

Symbols in the Owner's Manual

The following symbols are used in this Owner's Manual:

WARNING

Warning notes make you aware of dangers which could pose a threat to your health or life, or to the health and life of others.

Environmental note

Environmental notes provide you with information on environmentally aware actions or disposal.

 Notes on material damage alert you to dangers that could lead to damage to your vehicle.

 These symbols indicate useful instructions or further information that could be helpful to you.

▶ Instructions that must be followed.

▶ Several consecutive symbols indicate an instruction with several consecutive steps.

(▷ page) Further information on a topic

▷▷ A warning or an instruction that is continued on the next page.

Display text: Display text in the instrument cluster display, the smart Audio-System or the smart Media-System.

About this Owner's Manual

Before you first drive off, read this Owner's Manual carefully and familiarise yourself with your vehicle. For your own safety and a longer vehicle life, follow the instructions and warning notices in this manual. Disregarding them may lead to damage to the vehicle or personal injury.

This Owner's Manual provides information on the most important functions of your vehicle.

The equipment or model designation of your vehicle may vary according to:

- Model
- Order
- Country variant
- Availability

The illustrations in this manual show a left-hand-drive vehicle. On right-hand-drive vehicles, the layout of components and controls differs accordingly.

smart is constantly updating its vehicles to the state of the art.

smart therefore reserves the right to introduce changes in the following areas:

- Design
- Equipment
- Technical features

Therefore, the description may differ from your vehicle in some cases.

Integral parts of the vehicle include:

- Owner's Manual
- Service Booklet
- Equipment-dependent Supplements

These documents should be kept in the vehicle at all times. If you sell the vehicle, always pass all documents on to the new owner.

Your Owner's Manuals:



Digital on the Internet

The Owner's Manual on the Internet provides you with convenient access to all the information relevant to your vehicle and multimedia system. It also offers helpful animations, exciting background information and a wide variety of search options.



Digital as an app

Using the smart guides app, you can call up all of the information relevant to

your vehicle and multimedia system online on your phone or as a download regardless of the status of your network connection. Available for smartphones or tablets.

QR codes for the smart guides app.



Apple® iOS



Android™

Please note that the smart guides app may not currently be available in your country.

Index	4	Braking correctly	64
Introduction	18	Driving on wet roads	64
Protection of the environment	18	Winter driving	65
smart genuine parts	18	Lane Keeping Assist	65
Warranty for the smart Audio-System and smart Media-System	19	Cruise control and limiter	66
Vehicle equipment	19	Refuelling	67
Operating safety	19	Ensuring good visibility	70
QR codes for rescue card	22	Switching on the lighting	70
Data stored in the vehicle	22	Adjusting the lighting	71
Copyright information	23	Using the interior lighting	72
At a glance	24	Using the windscreen wipers	72
Cockpit	24	Folding the sun visor to the side	74
Multifunction steering wheel	25	Feeling comfortable in the vehicle interior	75
Centre console with drawer	26	Locking and unlocking the doors from the inside	75
Overhead control panel	27	Understanding the reversing function	76
Door control panel	28	Opening and closing the windows	76
Displays shown in the instrument cluster and the display	29	Using the soft top (smart fortwo cabrio)	77
Safety	30	Operating the climate control system	80
Occupant safety	30	Switching the seat heating on and off	83
Children in the vehicle	36	Using the accessories	83
Pets in the vehicle	45	Parking and getting out	85
Driving safely	46	Parking	85
Entering and setting up	49	Using the parking aid	85
Opening the door	49	Using the reversing camera	86
Correct driver's seat position	49	Locking the vehicle	87
Adjusting the seats	49	Priming and deactivating the anti-theft alarm system	88
Adjusting the steering wheel	51	Operating the on-board computer	89
Adjusting the mirrors	51	Overview of the on-board computer	89
Driving	53	Calling up displays	90
Running-in a new vehicle	53	Setting values	92
Starting the engine	53	Using the smart Audio-System	94
Pulling away	54	Operating and setting the smart Audio-System	94
Automatic start/stop system	56		
Manual transmission	57		
Automatic transmission	57		
Using the turn signals	60		
Driving economically	60		

Listening to the radio	96	Removing the first-aid kit	149
Using a mobile phone	98	Removing the fire extinguisher	149
Operating external data storage media	100	Removing the vehicle tool tray	149
Using the smart Media-System		Sealing tyres using the TIREFIT kit ..	150
Operating and setting up the smart Media-System	102	Jump-starting and charging the battery	152
Listening to the radio	106	Towing and tow-starting the vehi- cle	155
Using a mobile phone	108	Manually releasing the selector lever lock	158
Connecting and operating external data storage media	111	Replacing the bulbs	158
Viewing images	112	Changing fuses	161
Video playback	113	Replacing the key battery	162
Using the navigation system	113	Opening a door with the emergency release	163
Managing apps	122	Locking the doors in an emergency ..	163
Loading and stowing		Practical advice	
Stowing small objects	124	Notes on display messages	165
Stowing luggage and large objects ...	125	Locking and unlocking	165
Using the boot separator	127	Visibility, occupants, airbags	167
Maintenance and care		Engine, brakes, transmission	169
Useful information	129	Driving safety systems	176
Removing/fitting the subwoofer	129	Driver assistance systems	182
Opening and closing the engine compartment cover	129	Battery, lights, heating	184
Opening and closing the service cover	130	smart Audio-System and smart Media-System	186
Checking service products and top- ping up	131	Technical data	
Checking wheels and tyres	134	Obtaining technical data	188
Changing a wheel	135	Reading out vehicle data	188
Using the tyre pressure monitor	139	Service products	190
Checking the tyre pressures	140	Bulb types	190
Using winter tyres	141	Fuse allocation	190
Using snow chains	141	Radio type approvals for the tyre pressure monitors	192
Changing the window wiper blades ..	141	Retrofitting two-way radios and mobile phones (RF transmitters)	192
Cleaning the vehicle	143		
Observing service due dates	147		
Parking up the vehicle	147		
Dealing with accidents and break- downs			
Securing the vehicle in the event of an accident or a breakdown	148		

- A**
- ABS (Anti-lock Braking System)**
 Display message 176
 Function/notes 46
 Warning lamp (yellow) 176
- Adjusting the headlamp range** 71
- Air conditioning**
 General notes 80
- Air conditioning system**
 Demisting the windscreen 81
- Air distribution**
 Setting (air-conditioning system) 80
 Setting (automatic climate control) 81
- Air pressure**
 see Tyre pressure
- Air vents**
 Important safety notes 82
 Setting 82
- Air vents**
 see Air vents
- Air-conditioning system**
 Activating/deactivating air-recirculation mode 80
 Air distribution 80
 Cooling with air dehumidification 81
 Demisting the rear window 81
 Increasing or decreasing the blower speed 80
 Setting the temperature 80
 Switching on/off 80
 Windows misted up 81
- Air-recirculation mode**
 Activating/deactivating (air-conditioning system) 80
 Switching on/off (automatic climate control) 82
- Airbag**
 Enabling and disabling the passenger airbag* 39
 Installation locations 33
 Limited protection 34
 Overview 33
 PASSENGER AIR BAG indicator lamps 35
- Airbags**
 Front airbag (driver, front passenger) 33
 Kneebag 33
 Protection provided 34
 Sidebag 33
 Triggering 31
- Alarm**
 Anti-theft alarm system 88
 Switching off 88
- Ambient lighting**
 Setting the brightness 92
 Switching on/off 92
- Animals**
 see Pets in the vehicle
- Anti-lock Braking System**
 see ABS (Anti-lock Braking System)
- Anti-skid chains**
 see Snow chains
- Anti-theft alarm system**
 Priming/deactivating 88
 Switching off the alarm 88
- Aquaplaning** 64
- Ashtray** 83
- Audio-System**
 Connecting a mobile phone 98
 Connecting a USB device 100
 Connecting Bluetooth® audio devices 101
 Connecting external audio equipment (AUX) 100
 Operating 94
 Operating the radio 96
 Overview 94
 Selecting a track 100
 System settings 95
 Troubleshooting 186
 Volume/sound settings 96
 Warranty 19
- Authorised workshop**
 see Qualified specialist workshop
- Automatic climate control**
 Cooling with air dehumidification 82
 Demisting the rear window 82
 Demisting the windscreen 82
 Increasing or decreasing the blower speed 81

- Setting air distribution 81
 Setting the temperature 81
 Switching air-recirculation
 mode on/off 82
 Switching on/off 81
 Windows misted up 82
- Automatic engine switch-off (auto-
 matic start/stop system)** 56
- Automatic headlamp mode** 70
- Automatic start/stop system**
 Activating/deactivating 56
 General information 56
- Automatic transmission**
 Display message 174
 Drive programs 58
 Emergency running mode 175
 Engaging neutral 58
 Engaging reverse gear 58
 Engaging the park position 58
 Gearshift paddles 60
 Gearshift recommendation 61
 Kickdown 58
 Malfunction (on-board com-
 puter with colour display) 174
 Malfunction (on-board com-
 puter with monochrome dis-
 play) 174
 Manual shifting 59
 Manually releasing the selector
 lever lock 158
 Pulling away 54
 Starting the engine 53
 Transmission positions 57
- Automatic transmission emergency
 running mode** 175
- AUX jack**
 Audio-System 94
 Media-System 102
- B**
- Battery (key)**
 Important safety notes 162
 Replacing 162
- Battery (vehicle)**
 Charging 152
 Display message 184
 Important safety notes 152
- Jump starting 154
 Warning and indicator lamps 184
- Belt tensioner**
 Activation 31
- Blower speed**
 Increasing or decreasing (air-
 conditioning system) 80
 Increasing or decreasing (auto-
 matic climate control) 81
- Bonnet (front)**
 see Service cover
- Boot**
 see Tailgate
- Boot separator** 127
 Fitting 127
 Removing 128
- Brake**
 EBD 48
- Brake fluid**
 Display message 172
- Brake force distribution**
 see EBD (electronic brake force
 distribution)
- Brake lamp**
 Replacing bulbs 159
- Brake lamps**
 Display message 184
- Brakes**
 ABS 46
 Driving tips 64
 Important safety notes 64
 Parking brake 55
 Warning lamp 172
- Breakdown**
 see Flat tyre
 see Towing away/tow-starting
- C**
- Car**
 see Vehicle
- Car wash (care)** 143
- Care**
 Automatic car wash 143
 Carpets 146
 Cleaning the interior 145
 Display 145
 Exhaust pipe 144

- Exterior 145
- Exterior lighting 145
- Gear or selector lever 145
- High-pressure cleaner 143
- Interior 145
- Notes 143, 145
- Paint 145
- Plastic trim 146
- Reversing camera 144
- Roof lining 145, 146
- Seat belt 146
- Seat cover 146
- Sensors 144
- Soft-top system 145
- Steering wheel 145
- Washing by hand 143
- Wheels 144
- Windows 144
- Wiper blades 145
- Central locking**
 - Automatic locking 75
 - Locking/unlocking (key) 87
- Centre console**
 - Overview 26
- Changing bulbs**
 - Tail lamps 159
- Changing the route**
 - Navigation 117
- Child restraint system**
 - Suitability of the seats for attaching belt-secured child restraint systems 42
 - Suitability of the seats for attaching ISOFIX child restraint systems 43
- Child seat**
 - Forward-facing restraint system 41
 - i-Size 37
 - ISOFIX 37
 - On the front-passenger seat 40
 - Rearward-facing restraint system 41
 - Recommendations 44
 - Suitability of the seats for i-Size child restraint systems 44
 - Suitable positions 41
 - Top Tether 38
- Children**
 - Restraint systems 36
- Cigarette lighter** 83
- Climate control**
 - Air conditioning 80
 - Automatic air conditioning 81
 - Setting the air vents 82
- Clock**
 - Setting the time (Media-System) 104
- Cockpit**
 - Overview 24
- Controlling speed**
 - see Cruise control
- Coolant**
 - Checking coolant level and topping up 133
 - Display message 171
 - Important safety notes 134
 - Temperature gauge 91
- Cooling**
 - see Climate control
- Cooling with air dehumidification**
 - Air-conditioning system 81
 - Automatic climate control 82
- Copyright** 23
- Cornering light function** 71
- Cover (front)**
 - see Service cover
- Crosswind Assist** 47
- Cruise control**
 - Activating 66
 - Buttons 66
 - Calling up the speed last stored 67
 - Cancelling cruise control 67
 - Deactivating 67
 - Display message (colour display) 183
 - Display message (monochrome display) 183
 - Function/notes 66
 - General notes 66
 - Important safety notes 66
 - Increasing/decreasing the speed 67
 - Storing and maintaining current speed 67

- Cup holder**
 Centre console 124
 Important safety notes 124
- Cup holder**
 see Cup holder
- D**
- DAB radio (Digital Audio Broadcasting)**
 Introduction 97
- Dashboard**
 Additional instruments 61
- Dashboard clock** 61
- Data**
 see Technical data
- Daytime driving lights** 70
- Dealership**
 see Qualified specialist workshop
- Declarations of conformity** 20
- Diagnostics connection** 21
- Digital radio** 97
 Audio-System 96
 Media-System 106
- Digital speedometer**
 Displaying 92
- Dipped-beam headlamps**
 Driving abroad 71
 Replacing bulbs 159
 Switching on/off 70
- Display**
 Colour 90
 Monochrome 89
- Display (cleaning instructions)** 145
- Display messages**
 General information 165
- Distance recorder**
 Monochrome display 90
- Distance recorder**
 see Trip meter
- Distance warning function**
 Display message 182
 Function/notes 46
 Warning lamp 182
- Door**
 Automatic locking (switch) 75
 Central locking/unlocking (key) 87
 Control panel 28
 Display message 166
 Emergency locking 163
 Emergency unlocking 163
 Opening (from the inside) 75
- Double lock function** 75
- Driver's door**
 see Door
- Driver's seat**
 see Seats
- Driving abroad**
 Symmetrical dipped beam 71
- Driving safety system**
 EBD (electronic brake force distribution) 48
- Driving safety systems**
 ABS (Anti-lock Braking System) 46
 Distance warning function 46
 ESP® (Electronic Stability Program) 47
 ETS (Electronic Traction System) 47
 Important safety guidelines 46
- Driving systems**
 Cruise control 66
 Lane Keeping Assist 65
 Speed limiter 66
- Driving tips**
 Aquaplaning 64
 Brakes 64
 Downhill gradient 64
 Driving in winter 65
 Driving on flooded roads 64
 Driving on wet roads 64
 Energy consumption 60
 General 60
 Icy road surfaces 65
 Limited braking efficiency on
 salted roads 64
 Pulling away 54
 Running-in tips 53
 Symmetrical dipped beam 71
 Wet road surface 64
- E**
- EBD (electronic brake force distribution)**
 Function/notes 48

- Indicator lamp 176
 - eco score**
 - Calling up 63
 - Comparing the trip 63
 - Evaluating the current trip 63
 - Function/notes 62
 - Resetting data 63
 - Saving the trip 63
 - eco score display**
 - Colour display 62
 - Monochrome display 62
 - Electromagnetic compatibility**
 - Declaration of conformity 21
 - Electronic Brake-force Distribution**
 - see EBD (electronic brake force distribution)
 - Electronic Traction System**
 - see ETS (Electronic Traction System)
 - Emergency release**
 - Driver's door 163
 - Emergency unlocking**
 - Vehicle 163
 - Engine**
 - Automatic start/stop system 56
 - Display message 170
 - Jump-starting 152
 - Running irregularly 169
 - Starting problems 169
 - Starting the engine with the key .. 53
 - Stopping 85
 - Tow-starting (vehicle) 157
 - Warning lamp (engine diagnostics) 170
 - Engine compartment cover** 129
 - Engine electronics**
 - Notes 19
 - Problem (fault) 169
 - Engine oil**
 - Checking the oil level 132
 - Display message 171
 - Notes about oil grades 190
 - Topping up 133
 - Warning lamp 171
 - Entering a destination**
 - Navigation 114
 - Environmental protection**
 - Returning an end-of-life vehicle 18
 - EPG**
 - Displaying 98
 - ESP® (Electronic Stability Program)**
 - Crosswind Assist 47
 - Display message 177
 - General notes 47
 - Important safety guidelines 47
 - Warning and indicator lamps 177
 - ETS (Electronic Traction System)** 47
 - Exhaust pipe**
 - Cleaning 144
 - Exterior lighting**
 - Cleaning 145
 - see Lights
 - Exterior mirrors**
 - Adjusting 52
 - Out of position (troubleshooting) 167
 - External audio equipment (AUX)**
 - Connecting (Audio-System) 100
 - External data carriers**
 - Connecting (Audio-System) 94
 - Connection (Media-System) 111
 - Operating (Audio-System) 100
 - Operation (Media-System) 111
- F**
- Favourites**
 - Creating (Media-System) 105
 - Managing (Media-System) 105
 - Fire extinguisher** 149
 - First-aid kit** 149
 - Fitting a wheel**
 - Fitting a wheel 138
 - Preparing the vehicle 136
 - Raising the vehicle 137
 - Removing a wheel 137
 - Securing the vehicle against rolling away 148
 - Flat tyre**
 - Preparing the vehicle 148
 - TIREFIT kit 150
 - Floormat** 84
 - Foglamps**
 - Switching on/off 71
 - Fording**
 - On flooded roads 64

Frequencies

- Mobile phone 192
- Two-way radio 192

Front airbag 33

Front cover

see Service cover

Front windscreen

see Windscreen

Front-passenger front airbag deactivation system

- PASSENGER AIR BAG indicator lamps 35
- Status indicator 35

Frontal area cover

see Service cover

Fuel

- Additives 67
- Displaying the current consumption 90
- Displaying the current consumption (colour display) 91
- Driving tips 60
- E10 67
- Grade (petrol) 67
- Important safety notes 67
- Problem (malfunction) 170
- Refuelling 67

Fuel filler flap

- Opening/closing 68
- Problem (malfunction) 166

Fuel gauge 89

Fuel level

- Gauge 89

Fuses

- Allocation chart 190
- Before changing 161
- Dashboard fuse box 161
- Important safety notes 161
- Opening the fuse box 161

G

Gear or selector lever (cleaning instructions) 145

Genuine Mercedes-Benz parts 18

Glove compartment 124

H**Handbrake**

see Parking brake

Hands-free system

see Mobile phone

Hazard warning lamps 148

Headlamp flasher 71

Headlamps

see Automatic headlamp mode

Heating

see Climate control

Hill start assist 55

I

i-Size child seat securing systems 37

Ice warning

- Warning lamp (colour display) 184
- Warning lamp (monochrome display) 184

Ignition lock

see Key positions

Immobiliser 85, 88

Indicator and warning lamp

Restraint system 168

Indicator and warning lamps

- Coolant 171
- Engine diagnostics 170

Indicator lamps

see Warning and indicator lamps

Instrument cluster

- Overview 29
- Warning and indicator lamps 29

Instrument cluster lighting

Setting 92

Intellitext™

Switching on 98

Interior lighting 51, 72

Changing bulbs 161

Setting the ambient lighting 92

Switching on/off 72

Intermittent wipe 73

ISOFIX child seat securing system 37

J**Jack**

Using 137

- Jump start (engine)**
see Jump starting (engine)
- Jump starting (engine)** 152
- K**
- Key**
Changing the battery 162
Loss 165
Position in the ignition lock 53
Problem (malfunction) 165
Starting the engine 53
- Key positions (ignition lock)** 53
- Kickdown** 58
- Kneebag** 33
- L**
- Lamps**
see Warning and indicator lamps
- Lane Keeping Assist**
Activating/deactivating 66
Function/information 65
Warning lamp (colour display) 183
Warning lamp (monochrome display) 183
- Lane recognition system (automatic)**
see Lane Keeping Assist
- Language (on-board computer)** 93
- Licence plate lighting**
Changing bulbs 160
- Lighting**
see Lights
- Lights**
Automatic headlamp mode 70
Cornering light function 71
Dipped-beam headlamps 70
Display message 185
Driving abroad 71
Foglamps 71
Hazard warning lamps 148
Headlamp flasher 71
Headlamp range 71
Light switch 70
Main-beam headlamps 70
Rear foglamp 71
Setting the ambient lighting 92
Side lamps 71
- Turn signals 60
see Interior lighting
see Replacing bulbs
- Limiter**
Calling up the stored limit
speed 67
Cancelling 67
Deactivating 67
Display message (colour display) 183
Exceeding the stored limit
speed 66
Increasing or reducing the
stored limit speed 67
- Limiting the speed**
see Speed limiter
- Loading guidelines** 125
- Locking**
see Central locking
- Locking (doors)**
Automatic 75
Emergency locking 163
From inside (central locking
button) 75
- Loudspeaker**
see Subwoofer
- Luggage cover**
see Boot separator
- M**
- M+S tyres (winter tyres)** 141
- Main-beam headlamps**
Replacing bulbs 159
Switching on/off 70
- Making a call**
Media-System 110
- Malfunction**
Restraint system 30
- Manual transmission**
Display message (colour display) 173
Display message (monochrome display) 173
Engaging reverse gear 57
Gear lever 57
Malfunction (on-board computer with colour display) 174

- Malfunction (on-board computer with monochrome display) 174
 - Pulling away 54
 - Shift recommendation 61
 - Shifting to neutral 57
 - Starting the engine 53
 - Manually releasing the selector lever lock (automatic transmission) ...** 158
 - Media-System**
 - Buttons on the multifunction steering wheel 102
 - Calling up menus 103
 - Connectivity manager 123
 - Controls 102
 - Creating favourites 105
 - Data connectivity 122
 - Display settings 104
 - eco score 63
 - Enabling data sharing 123
 - Home screen 103
 - Image playback 112
 - Installing apps 122
 - Multimedia menu 103
 - Navigation menu 113
 - Navigation system 113
 - Operating the radio 106
 - Overview 102
 - Problem solving 186
 - Reversing camera 86
 - Selecting a track 112
 - Selecting the language 104
 - Services menu 123
 - Setting warning tones 105
 - Status and information 104
 - System menu 104
 - System settings 104
 - Vehicle menu 103
 - Video playback 113
 - Volume/tone settings 105
 - Warranty 19
 - Message memory (colour display)** 91
 - MirrorLink®**
 - Connecting a mobile phone 109
 - Mobile phone**
 - Connecting (Audio-System) 98
 - Connecting (Media-System) 108
 - Frequencies 192
 - Installation 192
 - Transmission output (maximum) 192
 - Model series**
 - see Vehicle identification plate
 - Multi-functional seat**
 - see Seats
 - Multifunction steering wheel**
 - Overview 25
 - Music track**
 - Selecting (Audio-System) 100
 - Selection (Media-System) 112
- N**
- Navigation**
 - Alternative route 117
 - Changing the route 117
 - Current location 119
 - Destination memory 115
 - Entering a destination 114
 - Entering a destination by address 114
 - Entering a destination using the map 114
 - Entering a POI 115
 - Entering/saving your home address 115
 - Reading map data 114
 - Route details 116
 - Setting 121
 - Setting route planning 117
 - Setting the voice 121
 - Starting 113
 - Starting route calculation 116
 - Switching announcements on/off 118
 - TomTom Services 120
 - Traffic information 119
 - Troubleshooting 186
 - Way points 117
 - Notes on running in a new vehicle** 53
- O**
- Occupant safety**
 - Airbags 33
 - Belt warning 33
 - Children in the vehicle 36

PASSENGER AIRBAG indicator lamp	35
Pets in the vehicle	45
Restraint system	30
Restraint system warning lamp	30
Seat belts	31
Oil	
see Engine oil	
On-board computer	
Important safety notes	89
Menu overview (colour display)	90
Menu overview (monochrome display)	90
Operation	89
Overview	89
Selecting the language	93
Settings menu	92
On-board diagnostics interface	
see Diagnostics connection	
Operating instructions	
Vehicle equipment	19
Operating safety	19
Declaration of conformity	20
Operating system	
see On-board computer	
Outside temperature display	
Colour display	90
Monochrome display	89
Setting the units	93
Overhead control panel	27
Overrevving range	61
P	
Paint code	188
Paintwork (cleaning instructions)	145
Parking	85
Important safety notes	85
Parking brake	55
Reversing camera	86
Parking brake	
Display message	172
General information	55
Warning lamp	172
PASSENGER AIR BAG	
Disabling/activating	39
Indicator lamps	35

Passenger airbag	
Enabling and disabling*	39
Problem (malfunction)*	168
Passenger seat	
Folding down	127
Petrol	67
Pets in the vehicle	45
Plastic trim (cleaning instructions) ...	146
Power windows	
see Side windows	
Protection against theft	
Anti-theft alarm system	88
Protection of the environment	
General notes	18
Pulling away	
General notes	54

Q

QR code	
Rescue card	22
Qualified specialist workshop	21

R

Radio	
Display mode	106
Displaying radio text	97
Operating (Audio-System)	96
Operation (Media-System)	106
Radio text	
Displaying (Audio-System)	97
Displaying (Media-System)	107
Radio-based vehicle components	
Declaration of conformity	20
Rain/light sensor (display message) ..	184
Reading lamp	72
Rear foglamp	
Switching on/off	71
Rear foglamps	
Replacing bulbs	159
Rear lamps	
Changing bulbs	159
Rear parking aid	
Deactivating/activating	86
Function/notes	85
Rear soft top	
Closing	126
Opening	126

- Rear window heating**
 - Air-conditioning system 81
 - Automatic climate control 82
 - Rear window wiper**
 - Replacing the wiper blade 142
 - Switching on/off 73
 - Rear-view mirror** 51
 - Recycling**
 - see Protection of the environment
 - Refuelling**
 - Fuel filler flap 68
 - Fuel gauge 89
 - Important safety notes 67
 - Refuelling process 68
 - see Fuel
 - Replacing bulbs**
 - Brake lamp 159
 - Dipped-beam headlamps 159
 - Fitting/removing the cover
(front wheel arch) 159
 - Important safety notes 158
 - Licence plate lighting 160
 - Main-beam headlamps 159
 - Overview of bulb types 190
 - Rear fog lamp 159
 - Reversing lamp 159
 - Turn signals (front) 159
 - Turn signals (rear) 159
 - Replacing the bulb**
 - Turn signals 159
 - Rescue card** 22
 - Reserve fuel**
 - Display message 170
 - Restraint system**
 - Display message 168
 - Function during an accident 31
 - Limited protection 30
 - Malfunction 30
 - Operational readiness 30
 - Protection provided 30
 - System self-test 30
 - Warning lamp 168
 - Warning lamp (function) 30
 - Rev counter** 61
 - Reverse gear**
 - Engaging (automatic transmis-
sion) 58
 - Engaging (manual transmis-
sion) 57
 - Reversing camera**
 - Cleaning instructions 144
 - Function/notes 86
 - Switching on/off 87
 - Reversing feature**
 - Side windows 76
 - Reversing lamp**
 - Changing bulbs 159
 - Roof lining**
 - Cleaning 145
 - Roof lining and carpets (cleaning instructions)** 146
- S**
- Safety**
 - Children in the vehicle 36
 - see Occupant safety
 - see Operating safety
 - SD card**
 - Inserting an SD card 114
 - Removing an SD card 114
 - SD card slot 102
 - Seat**
 - Folding passenger seat down 127
 - Seat belt**
 - Limited protection 32
 - Protection provided 31
 - Seat belts**
 - Cleaning 146
 - Fastening 33
 - Releasing 33
 - Warning lamp 167
 - Warning lamp (function) 33
 - Seat heating** 83
 - Seats**
 - Adjusting (manually) 49
 - Cleaning the cover 146
 - Correct driver's seat position 49
 - Important safety notes 49
 - Switching seat heating on/off 83
 - Sensors (cleaning instructions)** 144
 - Service Centre**
 - see Qualified specialist workshop
 - Service cover** 130

- Service display**
 Calling up (on-board computer with colour display) 91
 Calling up (on-board computer with monochrome display) 90
- Service due date**
 Display message 175
- Service products**
 Brake fluid 190
 Coolant (engine) 134
 Engine oil 190
 Fuel 190
 Important safety notes 131
 Washer fluid 190
- Shift recommendation** 61
- Side lamps**
 Switching on/off 71
- Side spars**
 Fitting 79
 Removing 78
- Side windows**
 Important safety notes 76
 Opening/closing 77
 Problem (malfunction) 165
 Resetting 165
 Reversing feature 76
- Sidebag** 33
- smart Centre**
 see Qualified specialist workshop
- Snow chains** 141
- Socket (12 V)**
 Centre console 84
- Soft top**
 Cleaning 145
 Closing 77
 Important safety notes 77
 Opening 77
- Speakers**
 see Subwoofer
- Specialist workshop** 21
- Speed limiter**
 Activating 66
 Functions and conditions for activation 66
 Setting limit speed 67
- Speedometer**
 Digital 90
 see Instrument cluster
- Start/stop function**
 see Automatic start/stop system
- Starting (engine)** 53
- Starting the engine**
 see Starting (engine)
- Station**
 Setting (Media-System) 107
- Station search**
 Audio-System 97
 Media-System 107
- Stations**
 Setting (Audio-System) 96
 Storing (Audio-System) 97
- Steering**
 Display message (colour display) 181
 Warning lamps 181
- Steering wheel**
 Adjusting (manually) 51
 Button overview 25
 Cleaning 145
 Gearshift paddles 60
 Important safety notes 51
- Stowage areas** 124
- Stowage compartment in the tailgate** 124
- Stowage compartments**
 Centre console 124
 Cup holder 124
 Door 124
 Glove compartment 124
 Important safety information 124
 Spectacles compartment 124
- Subwoofer**
 Fitting/removing 129
- Sun visor** 74

T

- Tailgate**
 Opening dimensions 188
 Opening/closing 125
 Warning lamp 166
- Tailgate (Cabriolet)**
 Opening/closing 126
- Tank**
 see Fuel tank

- Technical data**
 Information 188
 Vehicle data 188
- Telephone**
 Charging (Media-System) 108
 see Mobile phone
- Telephone book**
 Loading (Audio-System) 98
- Telephone operation**
 Audio-System 99
- Temperature**
 Setting (air conditioning) 80
 Setting (automatic climate control) 81
- Time**
 Setting (Audio-System) 96
 Setting (on-board computer with colour display) 92
 Setting (on-board computer with monochrome display) 92
 Setting the time mode (on-board computer with colour display) 92
- TIREFIT kit** 150
- TomTom Services**
 Introduction 120
 My Services menu 120
 Traffic information menu 120
- Tool**
 see Vehicle tool kit
- Top Tether** 38
- Total distance recorder**
 Colour display 91
 Monochrome display 89
 Setting the display unit 93
- Touchscreen**
 Confirming settings with Done 103
 Operating the touchscreen 103
- Tow-starting**
 Emergency engine starting 157
 Important safety notes 155
- Towing**
 Important safety notes 155
 With the rear axle raised 157
- Towing away**
 Fitting the towing eye 156
 Removing the towing eye 157
 With both axles on the ground 156
- Track**
 Selecting (Audio-System) 100
 Selection (Media-System) 112
- Traffic reports**
 Switching on/off 97
- Transmission**
 see Automatic transmission
 see Manual transmission
- Transporting the vehicle** 157
- Trip computer**
 Displaying 91
- Trip meter**
 Colour display 91
 Displaying (on-board computer with colour display) 91
 Displaying (on-board computer with monochrome display) 90
 Resetting (on-board computer with colour display) 92
 Resetting (on-board computer with monochrome display) 92
- Trip meter**
 see Trip meter
- Turn signals**
 Replacing bulbs (front) 159
 Replacing the bulb 159
 Switching on/off 60
- Turn signals**
 see Turn signals
- Two-way radio**
 Frequencies 192
 Installation 192
 Transmission output (maximum) 192
- Type identification plate**
 see Vehicle identification plate
- Tyre pressure**
 Display message 178
 Not reached (TIREFIT) 151
 Reached (TIREFIT) 151
 Recommended 140
- Tyre pressure monitor**
 Function/notes 139
 Radio type approval for the tyre pressure monitor 192
 Restarting 139
 Warning lamp 178

Tyres

Changing a wheel	135
Checking	134
Direction of rotation	138
Important safety notes	134
M+S tyres (winter tyres)	141
Service life	136
Snow chains	141
Storing	139
Tyre tread	134
see Flat tyre	

U**Unlocking**

From inside the vehicle (central unlocking button)	75
With emergency key element	163

USB device

Connecting (Audio-System)	100
Connection (Media-System)	111
Operating (Audio-System)	100
Operation (Media-System)	111

USB port

Audio-System	94
Media-System	102

V**Vehicle**

Data acquisition	22
Electronics	19
Equipment	19
Implied warranty	19
Locking (in an emergency)	163
Locking (key)	87
Operating safety	19
Parking up	147
Raising	137
Registration	21
Securing from rolling away	148
Tow-starting	157
Towing away	155
Transporting	157
Unlocking (in an emergency)	163
Unlocking (key)	49
Vehicle data	188

Vehicle battery

see Battery (vehicle)

Vehicle data	188
Vehicle dimensions	188
Vehicle emergency locking	163
Vehicle identification number see VIN	
Vehicle identification plate	188
Vehicle tool kit	149
VIN	188

Voice control system

Entering a destination in the navigation system	115
Problems with the voice control system	187
Starting an application	102

Volume/sound settings

Audio-System	96
Media-System	105

W**Warning and indicator lamps**

ABS	176
Automatic Start/Stop function (green)	172
Automatic Start/Stop function (yellow)	172
Battery	184
Brakes	172
Distance warning function (red) ..	182
EBD	176
ESP® (yellow)	177
Lane Keeping Assist	182
Oil pressure	171
Overview	29
Parking brake	172
PASSENGER AIR BAG	35
PASSENGER AIRBAG OFF	168
Seat belt	167
Steering	181
Tyre pressure monitor	178
Warning triangle	149
Wheel bolt tightening torque	138

Wheels

Changing a wheel	135
Checking	134
Cleaning	144
Fitting a new wheel	138
Important safety notes	134

- Removing a wheel 137
- Snow chains 141
- Storing 139
- Tightening torque 138
- Windows**
 - Cleaning 144
 - see Side windows
- Windscreen**
 - Demisting (air-conditioning system) 81
 - Demisting (automatic climate control) 82
- Windscreen washer fluid**
 - see Windscreen washer system
- Windscreen washer system**
 - Important safety notes 134
 - Topping up 134
- Windscreen wipers**
 - Intermittent wipe 73
 - Problem (malfunction) 167
 - Rear window wiper 73
 - Replacing the wiper blades 141
 - Switching on/off 72
- Winter driving**
 - General notes 65
- Winter operation**
 - Slippery road surfaces 65
 - Snow chains 141
- Winter tyres**
 - M+S tyres 141
- Wiper blades**
 - Cleaning 145
 - Replacing (on the rear window) ... 142
 - Replacing (windscreen) 142
- Workshop**
 - see Qualified specialist workshop

Protection of the environment

General notes

🕒 Environmental note

Daimler's declared policy is one of integrated environmental protection.

The objectives are for the natural resources which form the basis of our existence on this planet to be used sparingly and in a manner which takes the requirements of both nature and humanity into account.

You too can help to protect the environment by operating your vehicle in an environmentally responsible manner.

Fuel consumption and the rate of engine, transmission, brake and tyre wear depend on the following factors:

- operating conditions of your vehicle
- your personal driving style

You can influence both factors.

You should bear the following in mind:

Operating conditions

- avoid short trips as these increase fuel consumption.
- make sure that the tyre pressures are always correct.
- do not carry any unnecessary weight.
- keep an eye on the vehicle's fuel consumption.
- remove rear racks once you no longer need them.
- a regularly serviced vehicle will contribute to environmental protection. You should therefore adhere to the service intervals.
- always have maintenance work carried out at a qualified specialist workshop, e.g. a smart Centre.

Personal driving style

- do not depress the accelerator pedal when starting the engine.
- do not warm up the engine with the vehicle stationary.

- drive carefully and maintain a safe distance from the vehicle in front.
- avoid frequent, sudden acceleration.
- change gear in good time, if possible in accordance with the gearshift recommendations in the multifunction display.
- shift up to the next gear as early as possible.
- switch off the engine in stationary traffic.

Returning an end-of-life vehicle

EU countries only:

smart will take back your end-of-life vehicle for environment-friendly disposal in accordance with the European Union (EU) End-Of-Life Vehicles Directive.

This makes an important contribution to closing the recycling circle and conserving resources. A network of vehicle take-back points and dismantlers has been established for you to return your vehicle. Returning vehicles to these facilities is free of charge.

For further information about the recycling and disposal of end-of-life vehicles, and the take-back conditions, please visit the national smart website for your country.

smart genuine parts

🕒 Environmental note

Daimler AG also supplies reconditioned assemblies and parts which are of the same quality as new parts. For these, the same warranty applies as for new parts.

📌 Airbags and seat belt tensioners, as well as control units and sensors for these restraint systems, may be installed in the following areas of your vehicle:

- doors
- door pillars
- door sills
- seats
- dashboard

- instrument cluster
- centre console

Do not install accessories such as audio systems in these areas. Do not carry out repairs or welding. You could impair the operating efficiency of the restraint systems.

Have accessories retrofitted at a qualified specialist workshop.

Only smart genuine parts or parts of the same quality may be used. In addition, only approved wheels, tyres and accessories for the particular type of vehicle may be used.

Always specify the vehicle identification number (VIN) when ordering smart genuine parts.

Using parts, tyres, wheels or safety-relevant equipment not approved by smart could jeopardise the operational safety of the vehicle. Safety-relevant systems, such as the brake system, may malfunction.

smart tests genuine parts and conversion parts and accessories that have been specifically approved for your vehicle for their reliability, safety and suitability. Despite ongoing market research, smart is unable to assess other parts. smart therefore accepts no responsibility for the use of such parts in smart vehicles, even if they have been officially approved or independently approved by a testing centre.

In Germany, certain parts are only officially approved for installation or modification if they comply with legal requirements. This also applies to some other countries. All genuine smart parts meet the approval requirements. The use of non-approved parts may invalidate the vehicle's general operating permit.

The following situations will invalidate the operating permit:

- The vehicle type changes from that stated in the vehicle's operating permit, due to modifications.
- Other road users are likely to be endangered.
- Emissions or noise characteristics deteriorate.

Warranty for the smart Audio-System and smart Media-System

The smart sales organisation provides a warranty for a period of 24 months without a kilometre limit for the smart Audio-System and the smart Media-System.

The warranty issuer is the respective sales organisation in the country in which the accessory or replacement part was purchased (see list in the service booklet).

Vehicle equipment

This Owner's Manual describes all models and all standard and optional equipment available for the vehicle at the time of publication of this Owner's Manual. Country-specific differences are possible. Please note that the vehicle equipment may differ from certain descriptions and illustrations provided in this manual. This is also the case for systems and functions relevant to safety.

The vehicle's original purchase contract documentation contains a list of all the systems in your vehicle. Please contact any smart centre to help clarify any questions related to the vehicle equipment and operation.

Operating safety

Important safety notes

WARNING

If you do not have the prescribed service/maintenance work or necessary repairs carried out, this could result in malfunctions or system failures. There is a risk of an accident.

Always have the prescribed service/maintenance work as well as necessary repairs carried out at a qualified specialist workshop.

WARNING

Flammable material such as leaves, grass or twigs may ignite if they come into con-

tact with hot parts of the exhaust system. There is a risk of fire.

When driving off road or on unpaved roads, check the vehicle's underside regularly. In particular, remove parts of plants or other flammable materials which have become trapped. In the case of damage, contact a qualified specialist workshop.

 **WARNING**

Operating the integrated information systems and communications equipment in the vehicle while driving will distract you from traffic conditions. You could then lose control of the vehicle. There is a risk of an accident.

Only operate these devices if road traffic conditions permit. If you are unsure about the surrounding conditions, pull over to a safe location and make entries only while the vehicle is stationary.

 **WARNING**

Modifications to electronic components, their software as well as wiring could affect their function and/or the operation of other networked components. This could in particular also be the case for systems relevant to safety. They might not function properly anymore and/or jeopardise the operational safety of the vehicle. There is an increased risk of an accident and injury.

Do not attempt to modify the wiring as well as electronic components or their software. Always have work on electrical and electronic components carried out at a qualified specialist workshop.

If you make any changes to the vehicle electronics, the general operating permit is rendered invalid.

 There is a risk of damage to the vehicle if:

- the vehicle becomes stuck, e.g. on a high kerb or an unpaved road
- you drive too quickly over an obstacle, e.g. a kerb, slowing thresholds or a pot-hole in the road
- a heavy object strikes the underbody or parts of the chassis

In situations like this, the body, underbody, chassis parts, wheels or tyres could be damaged without the damage being visible. Components damaged in this way can unexpectedly fail or, in the case of an accident, no longer withstand the strain they are designed to withstand.

If the underbody panelling is damaged, combustible materials such as leaves, grass or twigs can gather between the underbody and the underbody panelling. If these materials come into contact with hot parts of the exhaust system, they can catch fire.

In such situations, have the vehicle checked and repaired immediately at a qualified specialist workshop. If, on continuing your journey, you notice that driving safety is impaired, stop the vehicle immediately, paying attention to road and traffic conditions. In such cases, consult a qualified specialist workshop.

The multimedia device is equipped with technical provisions to protect it against theft. Further information is available from any smart Centre.

The functionality of a roof aerial (radio, DAB) may be impaired if roof carriers are used. Attaching metallised retrofit film to windows may also affect radio and GPS reception and have a negative impact on all other aerial functions in the vehicle interior.

Declarations of conformity

Wireless vehicle components

The following information applies to all components of the vehicle and the information systems and communication devices integrated into the vehicle which receive and/or transmit radio waves:

All wireless vehicle components as well as information systems and communications

equipment integrated into the vehicle are compliant with the basic requirements and all other relevant regulations stipulated in the 1999/5/EC Directive. Further information is available from any smart Centre.

Electromagnetic compatibility

The electromagnetic compatibility of the vehicle components has been checked and certified according to the currently valid version of Regulation ECE-R 10.

Diagnostics connection

The diagnostics connection is only intended for the connection of diagnostic equipment at a qualified specialist workshop.

WARNING

If you connect equipment to a diagnostics connection in the vehicle, it may affect the operation of vehicle systems. As a result, the operating safety of the vehicle could be affected. There is a risk of an accident.

Only connect equipment to a diagnostics connection in the vehicle, which is approved for your vehicle by Mercedes-Benz.

WARNING

Objects in the driver's footwell may restrict the clearance around the pedals or block a depressed pedal. This jeopardises the operating and road safety of the vehicle. There is a risk of an accident.

Stow all objects securely in the vehicle so that they do not get into the driver's footwell. Always fit the floor mats securely and as prescribed in order to ensure that there is always sufficient room for the pedals. Do not use loose floor mats and do not place several floor mats on top of one another.

 If the engine is switched off and a device is connected to a diagnostic connection, the battery may become discharged.

Connecting equipment to the diagnostics connection can result in the resetting of the emissions monitoring information,

for example. This may lead to the vehicle failing to meet the requirements of the next emissions test during the main inspection.

Qualified specialist workshop

A qualified specialist workshop has the necessary special skills, tools and qualifications to correctly carry out any necessary work on your vehicle. This particularly applies to work relevant to safety.

Observe the information contained in the Service Booklet.

Always have the following work carried out on your vehicle at a smart centre:

- work relevant to safety
- service and maintenance work
- repair work
- modifications, installations and conversions
- work on electronic components

Vehicle registration

smart may ask its smart centres to carry out technical inspections on certain vehicles. The quality or safety of the vehicle is improved as a result of the inspection.

smart is only able to notify the vehicle owner about vehicle inspections if smart has the vehicle registration data.

In the following cases, it is possible that a vehicle has not yet been registered in the owner's name:

- the vehicle was not purchased at an authorised specialist dealer
- the vehicle has not yet been examined at a smart centre

smart recommends registering the vehicle in a smart centre.

Notify smart as soon as possible if there is a change of address or if ownership of the vehicles changes. This can be done at a smart centre, for example.

Correct use

If warning stickers are removed, you may fail to recognise certain dangers. Leave warning stickers in place.

The following are important sources of information in regard to vehicle use:

- Safety notes in this Owner's Manual
- Technical data in this Owner's Manual
- Traffic rules and regulations
- Laws and safety standards pertaining to motor vehicles

Implied warranty

! Follow the instructions in this manual about the proper operation of your vehicle as well as about possible vehicle damage. Damage to your vehicle that arises from culpable contraventions against these instructions is not covered either by the smart implied warranty or by the New or Used-Vehicle Warranty.

QR codes for rescue card

The QR code is on the fuel filler flap and on the door pillar (B-pillar), on the opposite side. In the event of an accident, rescue services can use the QR code to quickly determine the corresponding rescue card for a vehicle. The current rescue card contains the most important information about the vehicle in compact form, such as the routing of the electric cables. Further information:

www.mercedes-benz.de/qr-code

Data stored in the vehicle

Many of the vehicle's electronic components contain data memories. These data memories store technical information temporarily or permanently on components, systems or the environment concerning:

- condition
- events
- faults

The data cannot be used to trace the vehicle's movements.

Examples of information stored include:

- the operating conditions of system components, such as fluid levels
- status messages concerning the vehicle and its individual components, such as speed and accelerator position
- malfunctions and defects in key system components, such as the lights and brakes
- vehicle reactions and operating conditions in specific driving situations, such as deployment of an airbag
- ambient conditions, such as outside temperature

This data is purely technical in nature and is used for the following:

- to assist in the detection and elimination of faults and defects
- to analyse vehicle functions, e.g. after an accident has occurred
- to optimise vehicle functions

This technical information is also read out for the following services:

- repair work
- service work
- warranty claims
- quality assurance

The readout is handled by service network staff (including the manufacturer) with the help of special diagnostic testers. You can obtain more information there, if required.

After the fault has been rectified, the information is cleared in the fault memory or is sequentially overwritten.

During vehicle operation, certain situations may arise in which this technical data - in conjunction with other information and, if applicable, after consultation with an approved assessor - may be linked to an individual person.

Examples of this include:

- accident reports
- vehicle damage
- witness evidence

Additional functions that have been contractually agreed upon with the customer also make it possible to transmit particular vehicle data from the vehicle, such as the vehicle location in the event of an emergency.

Copyright information

Information on licenses of Free and Open-Source software used in the vehicle and the electronic components:
<http://www.mercedes-benz.com/opensource>

Cockpit

>> At a glance.

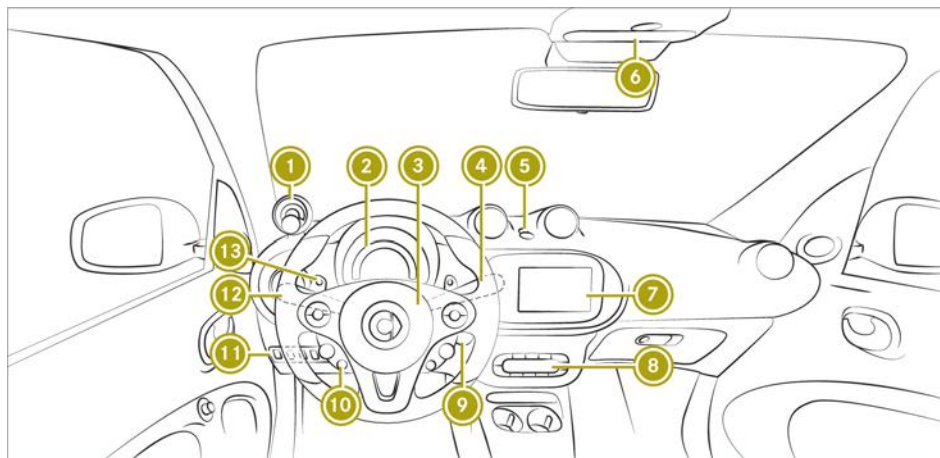

	Function	Page
①	Rev counter, dashboard clock	61
②	Instrument cluster	29
③	Horn	
④	Instrument cluster multi-function lever	90
	Windscreen wipers combination switch	72
⑤	Automatic locking feature	75
	Hazard warning lamps	148
⑥	Overhead control panel	27
⑦	smart Audio-System	94
	smart Media-System	102
⑧	Climate control system control panel	80

	Function	Page
⑨	Ignition lock	53
⑩	Adjusts the steering wheel	51
⑪	Control panel for:	
	Automatic start/stop system	56
	Lane Keeping Assist	65
	Forward collision warning	46
	Parking aid	85
	Headlamp range adjustment	71
⑫	Lights combination switch	70
⑬	Automatic transmission: shift paddles	60

Multifunction steering wheel

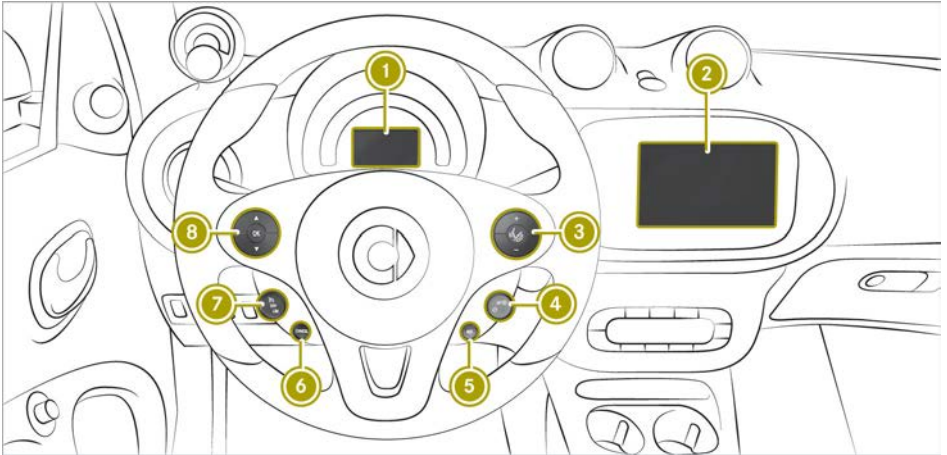

	Function	Page
①	Colour display of the instrument cluster Monochrome display of the instrument cluster	90 89
②	smart Audio-System smart Media-System	94 102
③	Only for instrument cluster with colour display: <input type="button" value="+"/> <input type="button" value="-"/> Adjusts the volume <input type="button" value="voice icon"/> Switches voice-operated control on or off and accepts or ends a call	102 102
④	<input type="button" value="SET +"/> Increases or stores the current speed - Decreases current speed	67 67

	Function	Page
⑤	<input type="button" value="RES"/> Calls up the last speed stored	67
⑥	<input type="button" value="CANCEL"/> Interrupts cruise control or the limiter	67
⑦	<input type="button" value="cruise icon"/> Activates cruise control <input type="button" value="OFF"/> Deactivates cruise control or the limiter <input type="button" value="LIM"/> Activates limiter	66 67 66
⑧	Only for instrument cluster with colour display: <input type="button" value="up arrow"/> <input type="button" value="down arrow"/> Scrolls through menus <input type="button" value="OK"/> Confirms the selection	90 92

Centre console with drawer

>> At a glance.

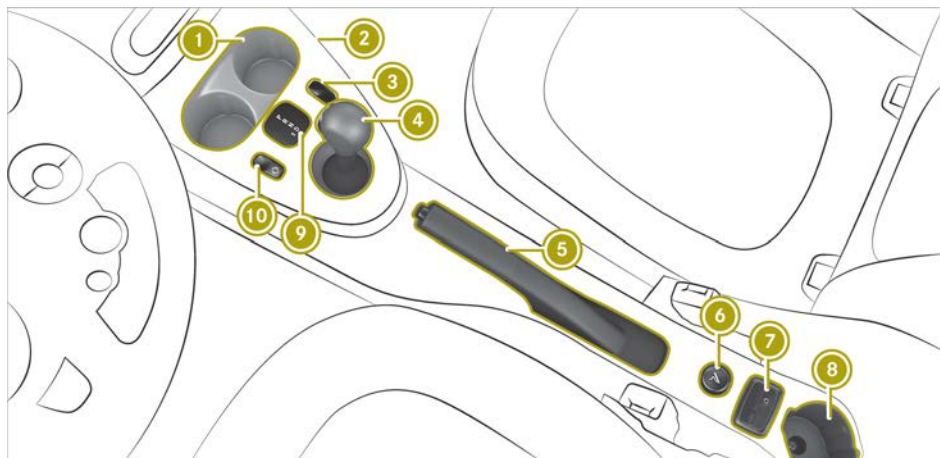

i Vehicles with automatic transmission

	Function	Page
①	Cup holders Ashtray	124 83
②	Drawer	124
③	smart fortwo coupé: coin holder	
③	smart fortwo cabrio: opens and closes the soft top	77
④	Selector lever	58
⑤	Parking brake	55

	Function	Page
⑥	Cigarette lighter Power socket	83 84
⑦	smart Media-System: AUX port, USB port and SD card slot	102
⑧	Cup holders	124
⑨	Selector lever indicator	57
⑩	Sets the drive programs (program selector button)	58

Overhead control panel

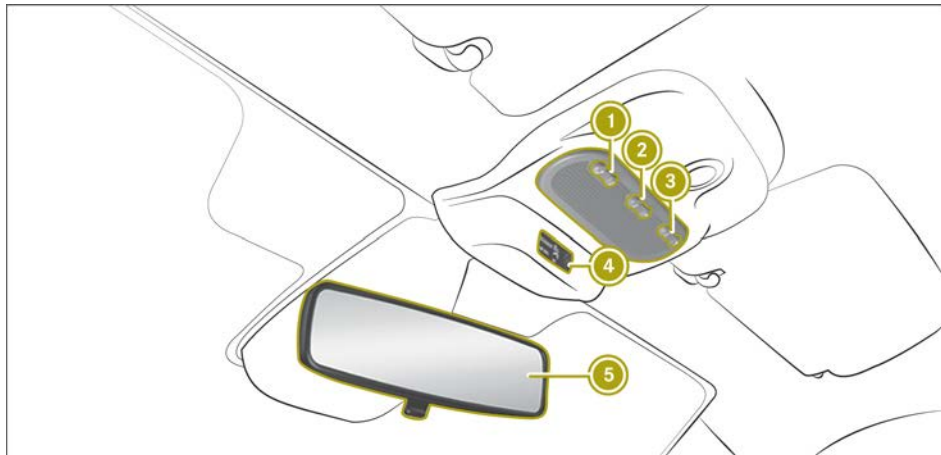

>> At a glance.

	Function	Page
①	Left-hand reading lamp	72
②	Interior lighting	72
③	Right-hand reading lamp	72

	Function	Page
④	PASSENGER AIRBAG indicator lamps	35
⑤	Rear-view mirror	51

Door control panel

>> At a glance.

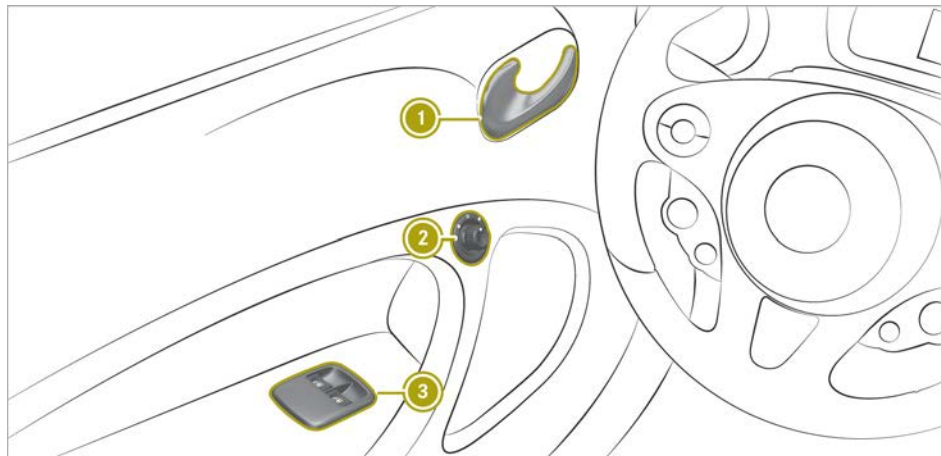

	Function	Page
①	Opens the door	75
②	Adjusts the exterior mirrors	52

	Function	Page
③	Opens and closes the side windows	77

Displays shown in the instrument cluster and the display

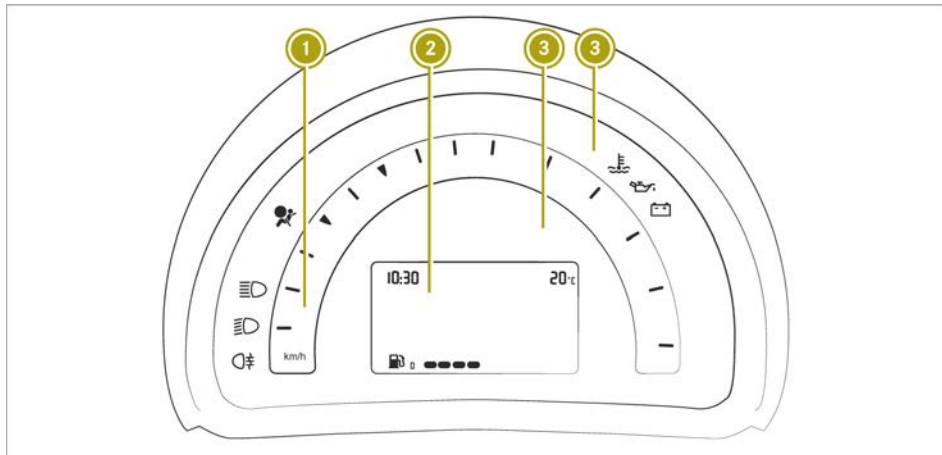

>> At a glance.

	Function	Page
①	Speedometer	
②	Display	
③	Warning and indicator lamps	
	Doors or tailgate	166
	Seat belts	167
	Restraint system	168
	Automatic start/stop system warning	172
	Automatic start/stop system	172
	Engine diagnostics	170
	Coolant temperature	171
	Oil pressure	171
	Brakes	172
	ABS	176
	ESP®	47
	Tyre pressure monitor	178
	Power steering	181

	Function	Page
	Distance warning signal	182
	Forward collision warning	182
	Lane Keeping Assist	182
	Battery	184
	Rear foglamp	71
	Foglamps	71
	Main-beam headlamps	70
	Dipped-beam headlamps	70
	Side lamps	71
	Transmission electronics	174
	Reserve fuel level reached	170
	Cruise control	183
	Limiter	183
	Black ice warning	184
	Brake lamps	184
	Next service due date	
		175

Occupant safety

Restraint system

Protection provided by the restraint system

The restraint system includes the:

- seat belt system
- airbags
- child restraint system
- child seat securing system

In an accident the restraint system can:

- reduce the risk of vehicle occupants coming into contact with parts of the vehicle interior
- reduce the forces to which vehicle occupants are subjected

A seat belt can only provide maximum protection when worn correctly. Depending on the type of accident detected, seat belt tensioners and/or airbags may supplement a correctly worn seat belt. Not every accident will trigger the seat belt tensioners and/or deploy the airbags.

To ensure that the restraint system provides the maximum protection, every vehicle occupant must:

- be seated with the seat belt fastened correctly
- be in an almost upright position with their back against the seat backrest
- have their feet resting on the floor, if possible
- always be secured in special restraint systems suitable for smart vehicles if under 1.50 m tall

However, no system available today can completely eliminate injuries and fatalities in every accident. In particular, the seat belt and airbag generally do not protect against objects penetrating the vehicle from the outside. The risk of injuries due to a deployed airbag also cannot be completely eliminated.

Limited protection from restraint system

WARNING

If the restraint system is modified, it may no longer work as intended. The restraint system may then not perform its intended

protective function by failing in an accident or triggering unexpectedly, for example. There is an increased risk of injury, possibly even fatal.



Never modify parts of the restraint system. Do not attempt to modify the wiring as well as electronic components or their software.

If the vehicle needs to be adjusted to accommodate a person with disabilities, contact a qualified specialist workshop. smart recommends that you only use driving assistance systems which have been approved for your vehicle by smart.

Preparing the restraint system for operation

When the ignition is switched on, the  restraint system warning lamp lights up during the system self-test. It goes out no later than a few seconds after the vehicle is started. The components of the restraint system are then ready for operation.

Restraint system malfunctions

- When the ignition is switched on, the  restraint system warning lamp does not light up.
- While driving, the  restraint system warning lamp remains lit or lights up repeatedly.

WARNING

If the restraint system is malfunctioning, restraint system components may be triggered unintentionally or may not deploy as intended during an accident. This may affect the seat belt tensioner or airbag, for example. This poses an increased risk of injury or even fatal injury.

Have the restraint system checked and repaired immediately at a qualified specialist workshop.

Restraint system response during an accident

The way the restraint system responds depends on the severity of the impact detected and the apparent type of accident:

- Head-on collision
- Rear impact
- Side impact

The activation threshold for the restraint system components is determined based on the analysis of the sensor values measured at various points in the vehicle. This process is pre-emptive in nature. The triggering process of the restraint system components should take place in good time at the start of the collision.

Factors which can only be seen and measured after a collision has occurred do not play a decisive role in the deployment of an airbag, nor do they provide an indication of airbag deployment.

The vehicle may be deformed significantly without an airbag being deployed. This is the case if only parts which are relatively easily deformed are affected and the rate of vehicle deceleration is not high. Conversely, an airbag may be deployed even though the vehicle suffers only minor deformation. If, for instance, very rigid vehicle parts such as longitudinal body members are hit, the rate of vehicle deceleration may be sufficient.

The restraint system components can be activated or triggered independently of each other:

Component	Detected trigger situation
Belt tensioners	Head-on collision, rear impact, side impact
Driver's airbag, front-passenger front airbag and kneebag	Head-on collision
Sidebag	Side impact

WARNING

After the airbag deploys, the airbag parts are hot. There is a risk of injury.

Do not touch the airbag parts. Have a deployed airbag replaced at a qualified specialist workshop as soon as possible.

- i** smart recommends that you have the vehicle towed to a qualified specialist workshop after an accident. Take this into account, particularly if a seat belt tensioner was triggered or an airbag was deployed.

If the belt tensioners are triggered or an airbag is deployed, you will hear a bang, and a small amount of powder may also be released:

- The bang will not usually affect your hearing.
- In general, the powder released is not hazardous to health but may cause short-term breathing difficulties to persons suffering from asthma or other pulmonary conditions.

Provided it is safe to do so, leave the vehicle immediately or open the window in order to prevent breathing difficulties.

Seat belts

Protection provided by seat belts

Always fasten seat belts correctly before starting your journey. A seat belt can only provide maximum protection when worn correctly.

WARNING

If the seat belt is worn incorrectly, it cannot perform its intended protective function. Furthermore, an incorrectly worn seat belt can cause additional injuries, e.g. in the event of an accident, heavy braking or sudden changes of direction. There is an increased risk of injury, possibly even fatal.

Always ensure that all vehicle occupants have their seat belts fastened correctly and are sitting properly.

- The seat belt must:
 - not be twisted and must be tight and fit snugly across your body
 - be routed across the centre of the shoulder and as low down across your hips as possible
- The shoulder section of the seat belt should not touch your neck nor be routed under your arm or behind your back.
- Avoid wearing bulky clothing, e.g. a winter coat.
- Press the lap belt down into your hip joints and pull tight by the shoulder section of the belt. The lap belt must never be routed across your stomach or abdomen.
- Never route the seat belt across sharp, pointed, abrasive or fragile objects.
- Only one person per seat belt. Infants and children must never travel sitting on the lap of a vehicle occupant.
- Never secure objects with a seat belt if the seat belt is also being used by one of the vehicle's occupants. Always observe the notes on "Loading the vehicle" for securing objects, luggage or loads (▷ page 125).

If children are travelling in the vehicle, be sure to observe the instructions and safety notes on "Children in the vehicle" (▷ page 36).

Limited protection from seat belts

WARNING

The seat belt does not offer the intended level of protection if you have not moved the backrest to an almost vertical position. When braking or in the event of an accident, you could slide underneath the seat belt and sustain abdomen or neck injuries, for example. This poses an increased risk of injury or even fatal injury.

Adjust the seat properly before beginning your journey. Always ensure that the backrest is in an almost vertical position and that the shoulder section of your seat-belt is routed across the centre of your shoulder.

WARNING

Persons under 1.50 m tall cannot wear the seat belts correctly without an additional suitable restraint system. If the seat belt is worn incorrectly, it cannot perform its intended protective function. Furthermore, an incorrectly worn seat belt can cause additional injuries, e.g. in the event of an accident, heavy braking or sudden changes of direction. There is an increased risk of injury, possibly even fatal.

Always secure persons less than 1.50 m tall in additional suitable restraint systems.

WARNING

Seat belts cannot protect as intended, if:

- they are damaged, have been modified, are extremely dirty, bleached or dyed
- the seat belt buckle is damaged or extremely dirty
- modifications have been made to the belt tensioners, belt anchorages or inertia reels

Seat belts may sustain non-visible damage in an accident, e.g. due to glass splinters. Modified or damaged seat belts can tear or fail, for example in the event of an accident. Modified seat belt tensioners may be deployed unintentionally or not function as intended. There is an increased risk of injury, possibly even fatal.

Never modify seat belts, seat belt tensioners, seat belt anchorages and inertia reels. Ensure that seat belts are not damaged or worn and are clean. After an accident, have the seat belts checked immediately at a qualified specialist workshop.

smart recommends that you only use seat belts which have been approved specifically for your vehicle by smart.

WARNING

Pyrotechnical belt tensioners which have been triggered are no longer operational and therefore cannot protect as intended.

There is an increased risk of injury, possibly even fatal.

Have pyrotechnic belt tensioners which have been triggered replaced at a qualified specialist workshop immediately.

smart recommends that you have the vehicle towed to a qualified specialist workshop after an accident.

- ❗ Make sure that the seat belt is fully rolled up. Otherwise, the seat belt or belt tongue will be trapped in the door or in the seat mechanism. This could damage the door, the door trim panel and the seat belt. Damaged seat belts can no longer fulfil their protective function and must be replaced. Visit a qualified specialist workshop.

Fastening and releasing the seat belt

If the seat belt is pulled out quickly or sharply, the inertia reel locks. The belt strap cannot be pulled out any further.

- ❗ If the co-driver's seat is not occupied, do not engage the seat belt tongue in the buckle on the co-driver's seat. Otherwise, the belt tensioner could be triggered in the event of an accident and would have to be replaced.

For easy fastening, the seat belt is guided through a belt loop on the side of the driver's seat.



- ① Buckle
- ② Belt tongue

- ▶ **To fasten:** always engage seat belt tongue ② into buckle ① of the corresponding seat.
- ▶ **To release:** press the release button in belt buckle ① and guide the seat belt back by belt tongue ②.

Belt warning for the driver and front-passenger

The  seat belt warning lamp in the instrument display is a reminder that all vehicle occupants must wear their seat belts correctly.

In addition, a warning tone may sound.

The belt warning goes out as soon as the driver and front-passenger fasten their seat belts.

- i If you are using an ISOFIX or an i-Size child restraint system on the front-passenger seat and the child is not secured using the seat belt of the front-passenger seat, the belt warning may be activated. In this case, you can insert the belt tongue of the seat belt into the belt buckle belonging to the front-passenger seat. To do this, guide the seat belt between the ISOFIX child restraint system and the backrest of the front-passenger seat.

Airbags

Overview of airbags

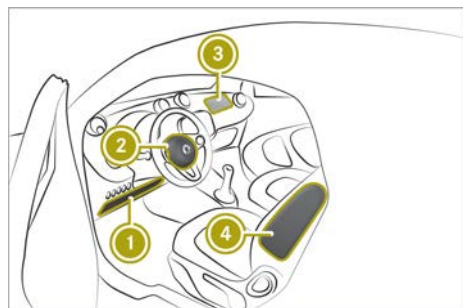

The installation location of an airbag is identified by the AIRBAG symbol.

A deployed airbag can increase the level of protection provided to the vehicle occupant.

	AIRBAG	Possible protection for:
①	Kneebag	Thigh, knee and lower leg
②	Driver's air-bag	Head and thorax
③	Front-passenger front airbag	Head and thorax
④	Sidebag	Head and thorax

The front-passenger front airbag can only be deployed in an accident if the PASSENGER AIR BAG ON indicator lamp is lit. If the front-passenger seat is occupied, make sure that the status of the front-passenger front airbag is correct both before and during the journey (▷ page 35).

Protection provided by the airbags

Depending on the type of accident, an airbag can supplement a correctly worn seat belt and provide added protection.

WARNING

If you deviate from the correct seat position, the airbag cannot perform its intended protective function and can even cause additional injuries when deployed. There is an increased risk of serious or even fatal injuries.

In order to avoid such risks, always ensure that all vehicle occupants:

- fasten their seatbelts correctly, including pregnant women
- are seated correctly and maintain the furthest possible distance from the airbags
- observe the following notes

Always ensure that there are no objects located between the airbag and the vehicle occupant.

To avoid risks as a result of a deployed airbag:

- Adjust seats correctly before starting your journey and move the driver's and front-passenger seat as far back as possible. Always observe the information on the correct driver's seat position (▷ page 49).
- Only hold onto the outside of the steering wheel rim. This allows the airbag to be fully deployed.
- Always lean against the backrest while driving. Do not lean forwards or lean against the door or side window. You may otherwise be in the deployment area of the airbags.
- Always keep your feet on the floor. Do not put your feet on the dashboard, for example. Your feet may otherwise be in the deployment area of the airbag.
- When children are travelling in the vehicle, follow the related additional notes (▷ page 36).
- Always properly stow and secure objects. Objects in the vehicle interior may limit an airbag's ability to function correctly. Therefore, always make sure that:
 - There are no people, animals or objects between the vehicle occupants and an airbag.
 - There are no objects between the seat, the door and the door pillar (B-pillar).
 - No hard objects, e.g. coat hangers, are hanging on the grab handles or coat hooks.
 - No accessories, such as cup holders, are attached to the vehicle within the deployment area of an airbag, e.g. to doors, side windows or side trim panels.
 - No heavy, sharp-edged or fragile objects are in the pockets of clothing. Store such objects in a suitable place.

Limited protection from airbags

WARNING

If you modify an airbag cover or affix objects such as stickers to it, the airbag can no longer function correctly. There is an increased risk of injury.

Never modify an airbag cover or affix objects to it.

⚠ WARNING

Unsuitable seat covers may obstruct or even prevent deployment of the airbags integrated into the seats. The airbags may then fail to protect the vehicle occupants as intended. There is an increased risk of injury, possibly even fatal.

Use only seat covers which have been specifically approved for the respective seat by smart.

⚠ WARNING

Sensors to control the airbags are located in the doors. Modifications or work not performed correctly to the doors or door panelling, as well as damaged doors, can lead to the function of the sensors being impaired. The airbags might therefore not function properly any more. Consequently, the airbags cannot protect vehicle occupants as they are designed to do. This poses an increased risk of injury.

Never modify the doors or parts of the doors. Always have work on the doors or door panelling carried out at a qualified specialist workshop.

⚠ WARNING

An airbag that has been deployed once cannot provide any further protection and, in the event of an accident, can no longer perform its intended protective function. There is an increased risk of injury.

Have the vehicle towed to a qualified specialist workshop to have the deployed airbag replaced.

Have deployed airbags replaced immediately.

Status of the front-passenger front airbag**PASSENGER AIR BAG indicator lamps**

The front-passenger front airbag can be enabled or disabled using the airbag-off

switch in the instrument cluster on the front-passenger side (▷ page 39).

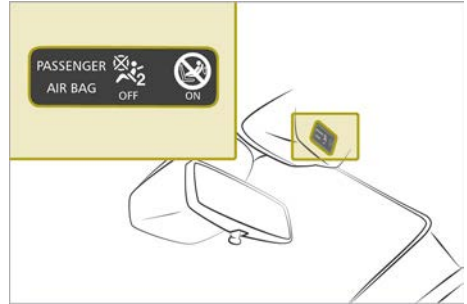

The PASSENGER AIRBAG OFF indicator lamp and PASSENGER AIRBAG ON indicator lamp are part of the front-passenger front airbag deactivation system.

The indicator lamps display the status of the front-passenger front airbag.

- **PASSENGER AIRBAG OFF** lights up: the front-passenger front airbag is disabled. It will then not be deployed in the event of an accident.
- **PASSENGER AIRBAG ON** lights up: the front-passenger front airbag is enabled. The front-passenger front airbag may deploy during an accident.

If the front-passenger seat is occupied, make sure that the status of the front-passenger front airbag is correct for the prevailing conditions both before and during the journey.

- **Children in a child restraint system:** whether the front-passenger front airbag must be enabled or disabled depends on the installed child restraint system, and the age and size of the child. Make sure that you observe the notes on "Children in the vehicle" (▷ page 36). There you will also find instructions on backwards and forwards-facing child restraint systems on the front-passenger seat.
- **All other persons:** the PASSENGER AIRBAG ON indicator lamp must be lit. The front-passenger front airbag is enabled. Be sure to observe the notes on "Seat belts" (▷ page 31) and "Airbags" (▷ page 34). There you can also find information on the correct seat position.

Observe the information on the airbag deactivation system of the front-passenger front airbag (▷ page 39).

Children in the vehicle

Travelling safely with children on board

WARNING

If you leave children unattended in the vehicle, they may be able to set the vehicle in motion if, for example, they:

- release the parking brake
- shift the automatic transmission out of park position **P** or shift manual transmission into neutral
- start the engine

In addition, they may operate vehicle equipment and become trapped. There is a risk of an accident and injury.

When leaving the vehicle, always take the key with you and lock the vehicle. Never leave children unattended in the vehicle.

WARNING

If persons (particularly children) are exposed to heat or cold for a prolonged period, there is a risk of serious or even fatal injuries. Never leave persons (particularly children) unattended in the vehicle.

WARNING

If the child restraint system is placed in direct sunlight, the parts could become very hot. Children could be suffer burns by touching these parts, in particular on the metallic parts of the child restraint system. There is a risk of injury.

If you and your child leave the vehicle, always make sure that the child restraint system is not in direct sunlight. Cover it with a blanket, for example. If the child restraint system has been exposed to direct sunlight, leave it to cool down before securing the child in it. Never leave children unattended in the vehicle.

To provide better protection to children younger than 12 years old and under 1.50 m tall, smart recommends always observing the following:

- Secure children only in a child restraint system that is appropriate for the age, weight and size of the child and that is recommended and suitable for use in smart vehicles. Make sure you observe the instructions for correct use of the child restraint system.
- Only use the following securing systems with the child restraint systems:
 - the seat belt system
 - the ISOFIX or i-Size securing rings
 - the Top Tether anchorages
- The manufacturer's child restraint system installation instructions.
- The warning labels in the vehicle interior and on the child restraint system.

WARNING

If the child restraint system is incorrectly fitted on the seat position suitable for this purpose, it cannot perform its intended protective function. In the event of an accident, sharp braking or a sudden change in direction, the child may not be held securely. There is an increased risk of serious or even fatal injuries.

Observe the manufacturer's installation instructions and the correct use for the child restraint system. Make sure that the entire surface of the child restraint system is resting on the seat surface. Never place objects under or behind the child restraint system, e.g. cushions. Only use child restraint systems with the original cover designed for them. Only replace damaged covers with genuine covers.

WARNING

If the child restraint system is fitted incorrectly or is not secured, it can come loose in the event of an accident, heavy braking or a sudden change in direction. The child restraint system could be thrown about, striking vehicle occupants. There is an

increased risk of injury, possibly even fatal.

Always fit child restraint systems properly, even if they are not being used. Make sure that you observe the child restraint system manufacturer's installation instructions.

WARNING

Child restraint systems or their securing systems that have been damaged or subjected to a load in an accident cannot perform their intended protective function. In the event of an accident, sharp braking or a sudden change in direction, the child may not be held securely. There is an increased risk of serious or even fatal injuries.

Immediately replace child restraint systems that have been damaged or subjected to a load in an accident. Have the child restraint securing systems checked in a qualified specialist workshop before fitting a child restraint system again.

-  Use the smart care products to clean the child restraint systems recommended by smart. Further information can be obtained at a qualified specialist workshop.

Also, always observe the detailed information below:

- When fitting a child restraint system on the front-passenger seat, observe the notes on child restraint systems on the front-passenger seat (▷ page 40).
- Notes on attaching suitable child restraint systems (▷ page 41).
- Notes on recommended child restraint systems (▷ page 44).
- Instructions and safety notes on disabling and enabling the front-passenger front airbag (▷ page 39).
- Notes on seat belts (▷ page 31).

ISOFIX and i-Size child seat securing systems

Notes on ISOFIX and i-Size child seat securing systems

WARNING

ISOFIX child restraint systems or i-Size child restraint systems do not offer sufficient protection for children whose weight is greater than 22 kg, who are secured using the safety belt integrated in the child restraint system. The child could, for example, not be restrained correctly in the event of an accident. This poses an increased risk of injury or even fatal injury.

If the child weighs more than 22 kg, only use ISOFIX child restraint systems or i-Size child restraint systems with which the child is also secured with the vehicle seat belt. Also secure the child restraint system with the Top Tether belt, if available.

When fitting a child restraint system, be sure to observe the manufacturer's installation instructions and the instructions for correct use of the child restraint system.

ISOFIX and i-Size are standardised securing systems for special restraint systems. ISOFIX child restraint systems are approved in accordance with ECE R44, i-Size child restraint systems are approved in accordance with ECE R129.

Only child restraint systems that comply with the ECE R44 standard may be attached to the ISOFIX securing rings. ISOFIX child restraint systems approved in accordance with ECE R44 and i-Size child restraint systems approved in accordance with ECE R129 can be attached to i-Size securing rings.

If you are using an ISOFIX or an i-Size child restraint system on the front-passenger seat and the child is not secured using the seat belt of the front-passenger seat, the belt warning may be activated (▷ page 33).

To deactivate the belt warning for the front-passenger, proceed as follows:

- ▶ Insert the seat belt tongue into the buckle before the child restraint system is fitted to the front-passenger seat.
- ▶ Then fit the ISOFIX child restraint system to the front-passenger seat (with seat belt fastened).
Make sure that the seat belt does not become damaged.



P91.20-2400-31

Symbol for ISOFIX child seat securing system



P91.20-2391-31

Symbol for i-Size child seat securing system

Attaching ISOFIX and i-Size child seat securing systems

When fitting a child restraint system, be sure to observe the manufacturer's installation instructions and the instructions for correct use of the child restraint system.

Before driving the vehicle, make sure that the ISOFIX or i-Size child restraint system is engaged correctly in both ISOFIX or i-Size securing rings.

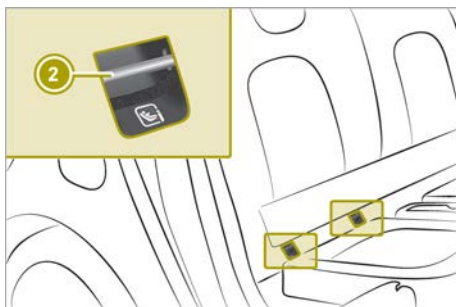
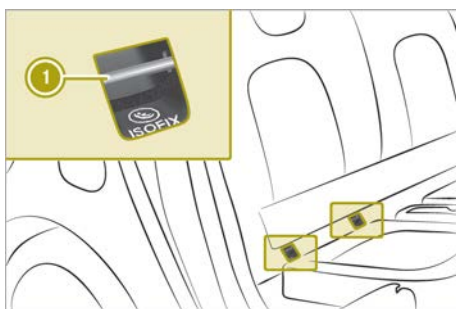

- ▶ Install the ISOFIX child restraint system on both ISOFIX securing rings ① or i-Size securing rings ②.

or

- ▶ Install the i-Size or ISOFIX child restraint system on both i-Size securing rings ②.

Securing Top Tether

Top Tether can reduce the risk of injury, since it provides an additional connection between the child restraint system secured with ISOFIX or i-Size and the vehicle.

The child restraint system must be equipped with a Top Tether belt.

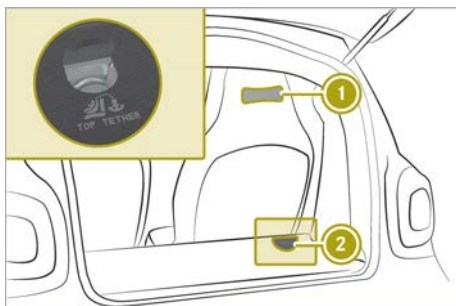

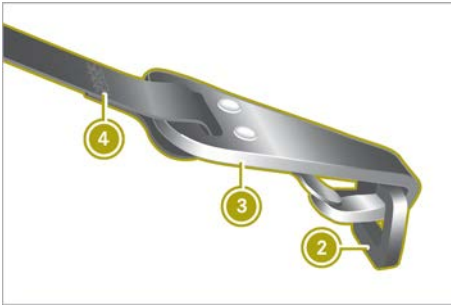

Top Tether anchorage ② is fitted to the luggage compartment floor.

- ▶ Fit the ISOFIX child restraint system with Top Tether. Always comply with the child restraint system manufacturer's installation instructions when doing so.
- ▶ Route Top Tether belt ④ back over the head restraint, keeping it as central as possible, into the luggage compartment through loop ①.
- ▶ Hook Top Tether hook ③ of Top Tether belt ④ into Top Tether anchorage ②. Lift up the carpet a little if necessary. Ensure that:
 - Top Tether hook ③ is hooked into Top Tether anchorage ② as shown.
 - Top Tether belt ④ is not twisted.
- ▶ Tension Top Tether belt ④. Always comply with the child restraint system manufacturer's installation instructions when doing so.

Disabling/enabling the front-passenger front airbag

⚠ WARNING

If the PASSENGER AIRBAG OFF indicator lamp is lit, the front-passenger front airbag is disabled. It will not be deployed in the event of an accident and cannot perform its intended protective function. A person in the front-passenger seat could then, for example, come into contact with the vehicle's interior, especially if the person is sitting too close to the dashboard.

This poses an increased risk of injury or even fatal injury.

In this case the front-passenger seat may not be used. You may only transport a child on the front-passenger seat if they are seated in a suitable rearward or forward-facing child restraint system. Always observe the information about suitable positioning of the child restraint system in this Owner's Manual as well as the child restraint system manufacturer's installation instructions.

⚠ WARNING

If you secure a child on the co-driver's seat in a rearward-facing child restraint system and the PASSENGER AIR BAG ON indicator lamp lights up, the co-driver's airbag could be deployed in the event of an accident. The child could be struck by the airbag. There is an increased risk of injury, possibly even fatal.

In this case, always ensure that the co-driver's airbag is disabled. The PASSENGER AIRBAG OFF indicator lamp must light up.

If the PASSENGER AIR BAG OFF indicator lamp remains off and/or the PASSENGER AIR BAG ON indicator lamp is lit, do not fit a rearward-facing child restraint system to the front-passenger seat. For more information, see "Problems with automatic front-passenger airbag deactivation" (▷ page 168).

⚠ WARNING

If you secure a child in a forward-facing child restraint system on the front-passenger seat and you position the front-passenger seat too close to the dashboard, in the event of an accident, the child could:

- come into contact with the vehicle's interior if the PASSENGER AIR BAG OFF indicator lamp is lit, for example
- be struck by the airbag if the PASSENGER AIR BAG ON indicator lamp is on.

This poses an increased risk of injury or even fatal injury.

Move the front-passenger seat as far back as possible. Always make sure that the shoulder belt strap is correctly routed from the vehicle belt outlet to the shoulder belt guide on the child restraint system. The shoulder belt strap must be routed forwards and downwards from the vehicle belt outlet. If necessary, adjust the front-passenger seat accordingly. Additionally, always observe the information on suitable positioning of the child restraint system in this Owner's Manual in addition to the child restraint system manufacturer's installation instructions.



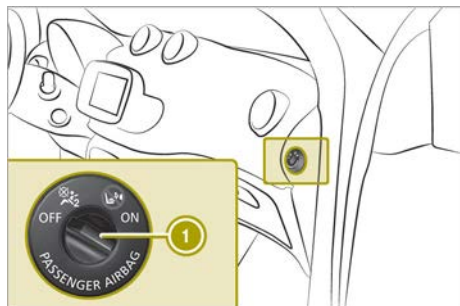

Warning symbol for a rearward-facing child restraint system

If you use a rearward-facing child restraint system on the front-passenger seat, you must disable the front-passenger front airbag.



The airbag-off switch for manually enabling and disabling the front-passenger front airbag is in the dashboard on the front-passenger side.

- ▶ Push in front-passenger airbag-off switch ① beyond the point of resistance.
- ▶ **To disable the front-passenger front airbag:** turn airbag-off switch ① anti-clockwise. The PASSENGER AIR BAG OFF  indicator lamp on the overhead control panel lights up and stays on when the ignition is switched on (▷ page 35).
- ▶ **To enable the front-passenger front airbag:** turn airbag-off switch ① clockwise. The PASSENGER AIR BAG ON  indicator lamp on the overhead control panel lights up and stays on when the ignition is switched on (▷ page 35).

The front-passenger airbag is enabled when the ignition is switched on unless the front-passenger front airbag has been manually disabled. If the front-passenger front airbag is disabled and the ignition is switched on, the PASSENGER AIR BAG OFF  indicator lamp in the overhead control panel (▷ page 35) lights up permanently.

Child restraint systems on the front-passenger seat

Notes on child restraint systems

If you secure a child in a child restraint system on the front-passenger seat, always observe the information on "Disabling the front-passenger front airbag" (▷ page 39).

You avoid risks when you:

- enable or disable the front-passenger front airbag correctly
- position the child restraint system favourably



A warning notice is located on the front-passenger sun visor.

WARNING

If you secure a child in a child restraint system on the front-passenger seat and the PASSENGER AIR BAG OFF indicator lamp is off, the front-passenger front airbag can deploy in the event of an accident. The child could be struck by the airbag. This poses an increased risk of injury or even fatal injury.

Make sure that the front-passenger front airbag has been disabled. The PASSENGER AIRBAG OFF indicator lamp must be lit.

NEVER use a rearward facing child restraint on a seat protected by an ACTIVE AIRBAG in front of it, DEATH or SERIOUS INJURY to the CHILD can occur.

Notes on rearward and forward facing child restraint systems



Warning symbol for a rearward-facing child restraint system

If you secure a child in a rearward-facing child restraint system on the front-

passenger seat, always make sure that the front-passenger front airbag is disabled. This is only the case if the PASSENGER AIR BAG OFF indicator lamp is permanently lit ([▷ page 35](#)).

When using child restraint systems on the front-passenger seat, always observe the following:

- Move the front-passenger seat as far back as possible.
- The base of the child restraint system must lie fully against the seat cushion of the front-passenger seat.
- The back of a forward-facing child restraint system must lie as flat as possible against the front-passenger backrest. The child restraint system must not touch the roof or be put under strain by the head restraint.
- Adjust the angle of the seat backrest accordingly.
- Always make sure that the shoulder belt strap is correctly routed from the vehicle belt outlet to the shoulder belt guide on the child restraint system. The shoulder belt strap must be routed forwards and rearwards from the vehicle belt outlet.
- Never place objects, such as a cushion, under or behind the child restraint system.

Always comply with the manufacturer's installation and operating instructions for the child restraint system used.

Suitability of the seats for child restraint systems

Notes on attaching suitable child restraint systems

Only child restraint systems that meet the following ECE standards are permitted for use in the vehicle:

- ECE R44
- ECE R129 (i-Size child restraint systems)



Label for an ECE R44 compliant child restraint system

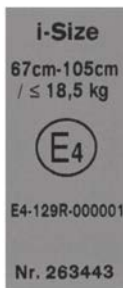

P91.00-2332-31

Label for an ECE R129 compliant child restraint system

ISOFIX or i-Size child restraint systems in the following "Universal" category may be used on seats marked U, UF, IUF or i-U in accordance with the tables on the suitability of the seats for attaching child restraint systems.

Semi-universal child restraint systems are indicated by the text "Semi-universal" on the approval label. Use is only permitted if the vehicle and the seat are listed in the child restraint system manufacturer's vehicle model list.

Suitability of the seats for attaching belt-secured child restraint systems

Observe the following notes:

- For certain child restraint systems in weight categories II or III, the maximum size setting may be restricted, for instance due to possible contact with the roof.
- The child restraint system must not touch the roof or be put under strain by the head restraint.
- Observe the child restraint system manufacturer's installation instructions.

Legend for the table:

- **X:** Not suitable for children in this weight category.
- **U:** Suitable for child restraint systems in the "Universal" category used in this weight category.
- **UF:** Suitable for forward-facing child restraint systems in the "Universal" category used in this weight category.
- **L:** Suitable for semi-universal child restraint systems in accordance with the table in "Overview of the recommended child restraint systems" (> page 44) or if the vehicle and the seat are listed in the child restraint system manufacturer's vehicle model list.

Weight categories	Front-passenger front air-bag is enabled	Front-passenger front air-bag is disabled ¹
Category 0: up to 10 kg	X	U, L
Category 0+: up to 13 kg	X	U, L
Category I: 9 to 18 kg	UF, L	U, L
Category II: 15 to 25 kg	UF, L	U, L
Category III: 22 to 36 kg	U, L	U, L

Suitability of the seats for attaching ISOFIX child restraint systems

Observe the following notes:

- For certain child restraint systems in weight categories II or III, the maximum size setting may be restricted, for instance due to possible contact with the roof.
- The child restraint system must not touch the roof or be put under strain by the head restraint.
- Observe the child restraint system manufacturer's installation instructions.

Legend for the table:

- **X:** Not suitable for an ISOFIX child restraint system in this weight category.
- **UF:** Suitable for forward-facing ISOFIX child restraint systems in the "Universal" category used in this weight category.
- **L:** Suitable for ISOFIX child restraint systems in accordance with the table in "Overview of the recommended child restraint systems" (▷ page 44) or if the vehicle and the seat are listed in the child restraint system manufacturer's vehicle model list.

Weight category		Size category	Equipment	Front-passenger front airbag is enabled	Front-passenger front airbag is disabled ²
Carry-cot		F	ISO/L1	X	X
		G	ISO/L2	X	X
0	up to 10 kg up to approximately 6 months	E	ISO/R1	X	IL
0+	up to 13 kg up to approximately 15 months	E	ISO/R1	X	IL
		D	ISO/R2	X	IL
		C	ISO/R3	X	IL
I	9 kg up to 18 kg between approximately 9 months and 4 years	D	ISO/R2	X	IL
		C	ISO/R3	X	IL
		B	ISO/F2	IUF	IUF

¹ The vehicle is equipped with a front-passenger front airbag deactivation system. The PASSENGER AIR BAG OFF indicator lamp must be lit.

² The vehicle is equipped with a front-passenger front airbag deactivation system. The PASSENGER AIR BAG OFF indicator lamp must be lit.

Weight category	Size category	Equipment	Front-passenger front airbag is enabled	Front-passenger front airbag is disabled ²
	B1	ISO/F2X	IUF	IUF
	A	ISO/F3	IUF	IUF

Suitability of the seats for attaching i-Size child restraint systems

Observe the following notes:

- For certain child restraint systems in weight categories II or III, the maximum size setting may be restricted, for instance due to possible contact with the roof.
- The child restraint system must not touch the roof or be put under strain by the head restraint.
- Observe the child restraint system manufacturer's installation instructions.

Legend for the table:

- **X**: Not suitable for an i-Size child restraint system in this weight category.
- **i-U**: Suitable for a forward-facing or rearward-facing i-Size child restraint system in the "Universal" category.
- **i-UF**: Suitable for a forward-facing i-Size child restraint system in the "Universal" category.

	Front-passenger front airbag is enabled	Front-passenger front airbag is disabled ³
i-Size child restraint systems	i-UF	i-U

Overview of recommended child restraint systems

The smart fortwo is equipped with a manual front-passenger front airbag deactivation system.

- ▶ Before using a rearward-facing child restraint on the front-passenger seat, disable the front-passenger airbag (▷ page 39).

Recommended child restraint systems for attaching with the vehicle seat belt

Weight category	Manufacturer	Type	Approval number(E1 ...)	Order number (A 000 ...) with colour code 9H95
Category 0: up to 10 kg up to approximately 6 months	Britax Römer	BABY SAFE PLUS	03 301146 04 301146	970 10 00
		BABY SAFE plus II	04 301146	970 20 00 970 36 00

² The vehicle is equipped with a front-passenger front airbag deactivation system. The PASSENGER AIR BAG OFF indicator lamp must be lit.

³ The vehicle is equipped with a front-passenger front airbag deactivation system. The PASSENGER AIR BAG OFF indicator lamp must be lit.

Weight category	Manufacturer	Type	Approval number(E1 ...)	Order number (A 000 ...) with colour code 9H95
Category 0+: up to 13 kg up to approximately 15 months	Britax Römer	BABY SAFE PLUS	03 301146 04 301146	970 10 00
		BABY SAFE plus II	04 301146	970 20 00 970 36 00
Category I: 9 kg up to 18 kg between approximately 9 months and 4 years	Britax Römer	DUO PLUS	03 301133 04 301133	970 16 00 970 37 00
Category II/III: 15 kg up to 36 kg	Britax Römer	KIDFIX	04 301198	970 19 00 970 38 00
		KIDFIX XP	04 301304	970 61 00

Recommended ISOFIX child restraint systems for the "Universal"/"Semi-Universal" category

Weight category	Size category	Manufacturer	Type	Approval number (E1 ...)	Order number with colour code 9H95
Category 0+: up to 13 kg	E	Britax Römer	BABY SAFE plus	03 301146 04 301146	B6 6 86 8224
Category I: 9 kg up to 18 kg	B1	Britax Römer	DUO PLUS	03 301133 04 301133	A 000 970 1600 A 000 970 3700

i You can obtain further information about the correct child restraint system from a smart centre.

Further related subjects:

- Notes on child restraint systems on the front-passenger seat (▷ page 40).
- Notes on attaching suitable child restraint systems (▷ page 41).

Pets in the vehicle

⚠ WARNING

If you leave animals unsupervised or unsecured in the vehicle, they may push a button or a switch, for example.

They could:

- activate vehicle equipment and become trapped, for example
- switch vehicle systems on or off, thus endangering other road users

In the event of an accident, sudden braking or abrupt changes of direction, unsecured animals could be flung around the vehicle, injuring the vehicle occupants. There is a risk of an accident and injury.

Never leave animals unattended in the vehicle. Always secure animals correctly during a journey, e.g. in an animal transport box.

Driving safely

Driving safety system limitations

I Make sure you have suitable tyres, so that assistance systems and driving safety systems can work as effectively as possible.

If you fail to adapt your driving style or if you are inattentive, the driving safety systems can neither reduce the risk of accident nor override the laws of physics. Driving safety systems are merely aids designed to assist driving. You are responsible for the distance to the vehicle in front, for vehicle speed and for braking in good time. Always adapt your driving style to suit the prevailing road, weather and traffic conditions and maintain a safe distance from the vehicle in front. Drive carefully.

For safety reasons, smart recommends that you only use snow chains that have been specially approved for your vehicle by smart. Further information can be obtained at a smart centre or a qualified specialist workshop.

Braking with ABS (Anti-lock Braking System)

ABS regulates brake pressure in such a way that the wheels do not lock when you brake. This allows you to continue steering the vehicle when braking.

When you switch on the ignition, the  warning lamp in the instrument cluster lights up. It goes out after the engine is started.

ABS works from a speed of about 6 km/h, regardless of road-surface conditions. ABS intervenes in the case of slippery road surfaces, even when you only brake gently.

- ▶ **To brake while ABS intervenes:** continue to depress the brake pedal with force until the braking situation is over.
- ▶ **To make a full brake application:** depress the brake pedal with full force.

WARNING

If ABS is faulty, the wheels could lock when braking. The steerability and braking characteristics may be severely impaired. Additionally, further driving safety systems are deactivated. There is an increased danger of skidding and accidents.

Drive on carefully. Have ABS checked immediately at a qualified specialist workshop.

Using the forward collision warning

If a risk of collision with the vehicle in front is detected, the forward collision warning alerts the driver both visually and acoustically.

The forward collision warning is activated when you start the engine.

With the help of the radar sensor system, the forward collision warning can detect obstacles that are in the path of your vehicle for an extended period of time.

Up to a speed of approximately 70 km/h, the forward collision warning can react to stationary obstacles, such as stationary or parked vehicles.

WARNING

The distance warning function does not react:

- to people or animals
- to oncoming vehicles
- to crossing traffic
- when cornering

Thus, the distance warning function cannot provide a warning in all critical situations. There is a risk of an accident.

Always pay careful attention to the traffic situation and be ready to brake.

WARNING

The distance warning function cannot always clearly identify objects and complex traffic situations.

In such cases, the distance warning function may:

- give an unnecessary warning
- not give a warning

There is a risk of an accident.

Always pay careful attention to the traffic situation; do not rely on the distance warning function alone.

The  warning lamp in the instrument cluster lights up if:

- the distance maintained to the vehicle travelling in front is insufficient
- the vehicle is rapidly approaching a vehicle travelling in front or a stationary object. In this case, an intermittent warning tone also sounds

Detection can be restricted under the following conditions:

- the vehicle is new or service work has been carried out on the system. In this case, observe the information on running-in the vehicle
- the sensors are dirty or covered
- in heavy rain or snow
- interference by other radar sources, e.g. in multi-storey car parks
- the vehicle travelling in front is narrow, e.g. a motorcycle
- the vehicle travelling in front is travelling on a different line

Following any damage to the front end of the vehicle, have the configuration and operation of the radar sensor checked at a qualified specialist workshop. This also applies to collisions at slow speeds where there is no visible damage to the front of the vehicle.

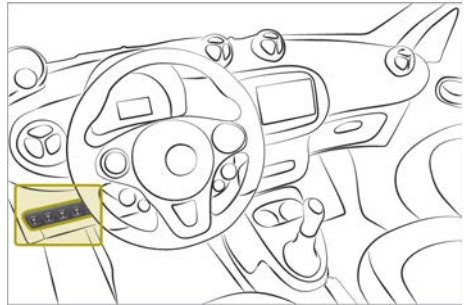

- ▶ Press the  switch symbol. **On-board computer with colour display:** the display shows a message. If the forward collision warning is deactivated, the indicator lamp lights up.

Driving with ESP®

ESP® supports the driver when pulling away on wet or slippery roads. ESP® can also stabilise the vehicle during braking. ESP® comprises ETS (Electronic Traction System) and Crosswind Assist.



If ESP® detects that the vehicle is deviating from the direction desired by the driver, one or more wheels are braked to stabilise the vehicle.

ETS brakes the drive wheels individually if they spin. This enables you to pull away and accelerate on slippery surfaces, for example if the road surface is slippery on one side.

Strong crosswind gusts can impair the road-holding of your vehicle when driving straight ahead.

Crosswind Assist reduces these impairments. Crosswind assist is active at vehicle speeds above 70 km/h when driving straight ahead or cornering gently.

If ESP® intervenes, pull away carefully and adapt your driving style to the prevailing road and weather conditions.

If the  warning lamp goes out before beginning the journey, ESP® is active. If ESP® intervenes, the  warning lamp flashes in the instrument cluster.

 **WARNING**

If ESP® is malfunctioning, ESP® is unable to stabilise the vehicle. In addition, other driving safety systems are switched off. This increases the risk of skidding and an accident.

Drive on carefully. Have ESP® checked at a qualified specialist workshop.

Information on EBD (Electronic Brake-force Distribution)

EBD monitors and controls the brake pressure on the rear wheels to improve driving stability while braking.

 **WARNING**

If EBD is malfunctioning, the rear wheels can lock, e.g. under full braking. This increases the risk of skidding and an accident.

You should therefore adapt your driving style to the different handling characteristics. Have the brake system checked at a qualified specialist workshop.

Opening the door

- ▶ Press the  button on the key.
- ▶ Open the door.
- i** After unlocking, open the vehicle within approximately 2 minutes to prevent it from locking itself and priming the anti-theft alarm system again.

Correct driver's seat position

WARNING

You could lose control of the vehicle while driving if you:



- adjust the driver's seat, steering wheel or mirror
- fasten the seat belt.

There is a risk of an accident.

Adjust the driver's seat, steering wheel or mirror and fasten the seat belt before starting the engine.



Observe the following rules on the correct driver's seat position:

- the driver must be as far away from the driver's airbag as possible (▷ page 33).
- the driver must be wearing seat belt  properly.
- the driver must be able to depress the pedals properly.
- the driver must be able to move their legs freely.
- the driver must be able to reach steering wheel  with their arms slightly bent.

- the driver must be able to see all the displays in the instrument cluster clearly.
- move seat backrest  to an almost vertical position.
- sit in a normal upright position.
- the seat belt must fit snugly across your body.
- the seat belt must be routed across the middle of your shoulder.
- the seat belt must be routed in your pelvic area across the hip joints.
- adjust the rear-view and exterior mirrors so that the driver has a good view of the road and traffic.

Adjusting the seats

Please note

WARNING

If children adjust the seats, they could become trapped, especially if they are unattended. There is a risk of injury.

When leaving the vehicle, always take the key with you and lock the vehicle. Never leave children unattended in the vehicle.

WARNING

If the driver's seat is not correctly engaged, it could unexpectedly move while driving. This could cause you to lose control of the vehicle. There is a risk of an accident.

Always ensure that the driver's seat is engaged before starting the vehicle.

WARNING

When adjusting a seat, you or another vehicle occupant could become trapped by the guide rail of the seat, for instance. There is a risk of injury.

Make sure that no one has any part of their body within the sweep of the seat when adjusting it.

WARNING

The seat belt does not offer the intended level of protection if you have not moved the backrest to an almost vertical position. When braking or in the event of an accident, you could slide underneath the seat belt and sustain abdomen or neck injuries, for example. This poses an increased risk of injury or even fatal injury.

Adjust the seat properly before beginning your journey. Always ensure that the backrest is in an almost vertical position and that the shoulder section of your seat-belt is routed across the centre of your shoulder.

WARNING

The steering wheel may move unexpectedly if you adjust it while driving. This could cause you to lose control of the vehicle. There is a risk of an accident.

Make sure that the steering wheel is locked before driving off. Never unlock the steering wheel when the vehicle is in motion.

WARNING

You could lose control of the vehicle while driving if you:

- adjust the driver's seat, steering wheel or mirror
- fasten the seat belt.

There is a risk of an accident.

Adjust the driver's seat, steering wheel or mirror and fasten the seat belt before starting the engine.

! Make sure that there are no objects in the footwell under or behind the seats when moving the seats back. There is a risk that the seats and/or the objects could be damaged.

Observe the safety notes on "Airbags" (> page 34) and "Children in the vehicle" (> page 36).

Adjusting the seat fore-and-aft position

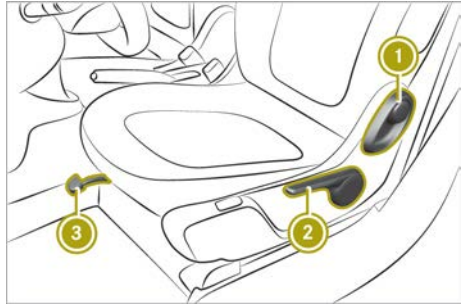

Seat with a lever

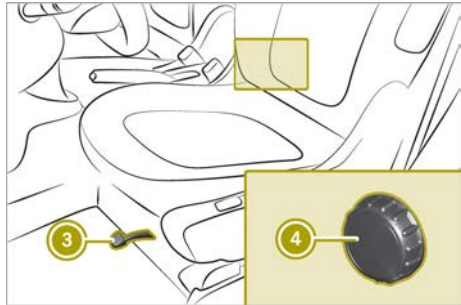

Seat with a handwheel

To adjust the seat fore-and-aft position, the seat belt must not be fastened.

- ▶ Lift lever ③.
- ▶ Slide the seat forwards or backwards. The seat engages audibly.

Adjusting the seat height (seat with a lever only)

- ▶ Pull handle ② up or push it down several times.

Adjusting the seat backrest (seat with a lever)

- ▶ Pull lever ① forwards.
- ▶ At the same time, move the backrest forwards or backwards.

Adjusting the seat backrest (seat with a handwheel)

- ▶ Turn handwheel ④ forwards or backwards.

Adjusting the steering wheel

⚠ WARNING

The steering wheel may move unexpectedly if you adjust it while driving. This could cause you to lose control of the vehicle. There is a risk of an accident.

Make sure that the steering wheel is locked before driving off. Never unlock the steering wheel when the vehicle is in motion.

⚠ WARNING

You could lose control of the vehicle while driving if you:

- adjust the driver's seat, steering wheel or mirror
- fasten the seat belt.

There is a risk of an accident.

Adjust the driver's seat, steering wheel or mirror and fasten the seat belt before starting the engine.

⚠ WARNING

Children could become trapped by the steering wheel if they adjust it. There is a risk of injury.

When leaving the vehicle, always take the key with you and lock the vehicle. Never leave children unattended in the vehicle.

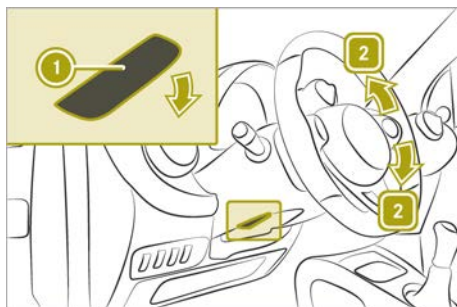

- ▶ Fold down lever ①.
- ▶ Set desired steering wheel height ②.
- ▶ Fold up lever ①.
- ▶ Check that the steering column is locked.

Adjusting the mirrors

Adjusting the interior mirror

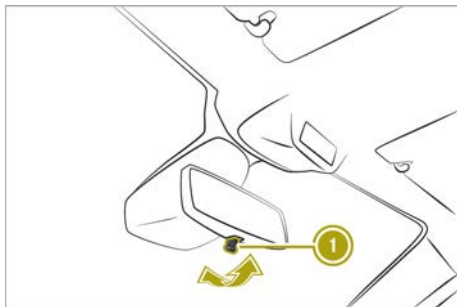

- ▶ Move the interior mirror up, down, left or right.

Setting the interior mirror to anti-dazzle mode

- ▶ Fold lever ① forwards.

Adjusting the exterior mirrors manually

⚠ WARNING

You could lose control of the vehicle while driving if you:

- adjust the driver's seat, steering wheel or mirror
- fasten the seat belt.

There is a risk of an accident.

Adjust the driver's seat, steering wheel or mirror and fasten the seat belt before starting the engine.

⚠ WARNING

The steering wheel may move unexpectedly if you adjust it while driving. This could cause you to lose control of the vehicle. There is a risk of an accident.

Make sure that the steering wheel is locked before driving off. Never unlock the steering wheel when the vehicle is in motion.

⚠ WARNING

The exterior mirrors reduce the size of the image. Objects visible in the mirrors are closer than they appear. You could misjudge the distance from road users driving behind you when changing lanes, for instance. There is a risk of an accident.

You should therefore always look over your shoulder to determine the actual distance from road users driving behind you.

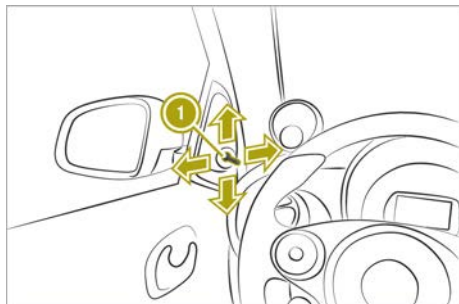

- Move lever ① up, down, left or right.

Adjusting the exterior mirrors electrically

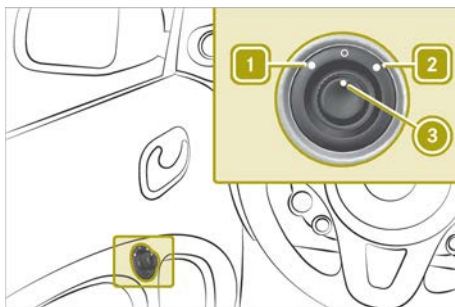

In order to adjust the exterior mirrors electrically, the ignition must be switched on.

- To select the left or right exterior mirror: turn control ③ left ① or right ②.
- To adjust the exterior mirrors: move control ③ up, down, left or right.

Running-in a new vehicle

Running-in the engine with due care improves the engine's performance in later years. After 1500 km, the engine speed can be increased gradually. Also follow the notes on running-in when the engine or parts of the drive train have been replaced.

In some drive and driving safety systems, the sensor system resets automatically after vehicle delivery or repairs. Full system effectiveness is not reached until the end of this teach-in procedure.

During the first 1500 km of the running-in period, note the following:

- ▶ Drive at varying vehicle and engine speeds.
- ▶ Avoid high engine loads, such as driving at full throttle.
- ▶ Drive at a speed that is less than $\frac{2}{3}$ the maximum speed.
- ▶ Do not use the engine brake to brake.
- ▶ **Vehicles with automatic transmission:** do not depress the accelerator beyond the pressure point (kickdown)
- ▶ **Vehicles with automatic transmission:** ideally drive the vehicle in drive program E (Comfort).

New brake pads/linings and discs only reach their optimum braking effect after several hundred kilometres of driving. Therefore, note the following during the running-in period:

- ▶ Drive carefully.
- ▶ Brake more firmly.

Starting the engine

Please note

WARNING

If children are left unsupervised in the vehicle, they could:

- open doors, thereby endangering other persons or road users
- get out and be struck by oncoming traffic
- operate vehicle equipment and become trapped, for example

In addition, the children could also set the vehicle in motion, for example, if they:

- release the parking brake
- shift the automatic transmission out of park position P or shift manual transmission into neutral
- start the engine

There is a risk of an accident and injury.

When leaving the vehicle, always take the key with you and lock the vehicle. Never leave children and animals unattended in the vehicle. Keep the keys out of the reach of children.

WARNING

Combustion engines emit poisonous exhaust gases such as carbon monoxide. Inhaling these exhaust gases leads to poisoning. There is a risk of fatal injury. Therefore never leave the engine running in enclosed spaces without sufficient ventilation.

WARNING

Flammable materials introduced through environmental influence or by animals can ignite if in contact with the exhaust system or parts of the engine that heat up. There is a risk of fire.

Carry out regular checks to make sure that there are no flammable foreign materials in the engine compartment or in the exhaust system.

WARNING

If you attach heavy or large objects to the key, the key could be unintentionally turned in the ignition lock. This could cause the engine to be switched off. There is a risk of an accident.

Do not attach any heavy or large objects to the key. Remove any bulky keyrings before inserting the key into the ignition lock.

- ❗ Do not depress the accelerator when starting the engine.

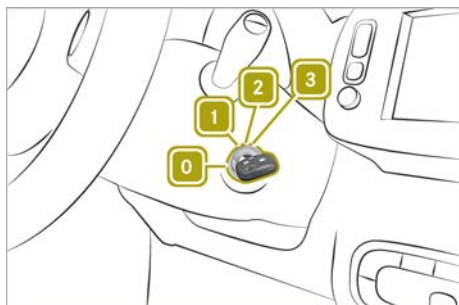

- 0 To insert the key into the ignition lock
- 1 To switch on the power supply
- 2 To switch on the ignition
- 3 To start the engine

Manual transmission

- ▶ Depress the brake pedal and keep it depressed.
- ▶ Depress the clutch pedal fully.
- ▶ Select neutral.
- ▶ Insert the key into the ignition lock.
- ▶ Turn the key to position **3**.

Automatic transmission

- ▶ Depress the brake.
- ▶ Turn the key to position **3**.
- ▶ Shift out of transmission position **P**.

Pulling away

Please note

WARNING

Objects in the driver's footwell can impede pedal travel or block a pedal which is depressed. This jeopardises safe operation of the vehicle. There is a risk of an accident. Stow all objects in the vehicle safely, so that they cannot reach the driver's footwell. Make sure the floor mats and carpets are properly secured so that they cannot slip and obstruct the pedals. Do not lay

several floor mats or carpets on top of one another.

WARNING

Unsuitable footwear can hinder correct usage of the pedals, e.g.:

- shoes with thick soles
- shoes with high heels
- slippers

There is a risk of an accident.

Wear suitable footwear to ensure correct usage of the pedals.

WARNING

If you switch off the ignition while driving, safety-relevant functions are only available with limitations, or not at all. This could affect, for example, the power steering and the brake boosting effect. You will require considerably more effort to steer and brake. There is a risk of an accident. Do not switch off the ignition while driving.

Note the following when pulling away:

- do not warm up the engine when the vehicle is stationary.
- do not drive with the parking brake applied.
- use caution when pulling away on slippery surfaces.
- do not allow tyres to spin.
- avoid excessive engine speeds and full throttle until the engine has reached its operating temperature.

Note the following on vehicles with automatic transmission:

- depress the brake pedal and keep it depressed.
- press the release button on the selector lever.
- shift the selector lever to position D or R.

Using the parking brake

Please note

WARNING

If the parking brake has not been fully released when driving, the parking brake can:

- overheat and cause a fire
- lose its hold function.

There is a risk of fire and an accident. Release the parking brake fully before driving off.

WARNING

If you must brake the vehicle with the parking brake, the braking distance is considerably longer and the wheels could lock. This increases the risk of skidding and an accident.

Only use the parking brake to brake the vehicle when the service brake is faulty. Do not apply the parking brake too firmly. If the wheels lock, release the parking brake until the wheels begin turning again.

WARNING

If you leave children unattended in the vehicle, they may be able to set the vehicle in motion if, for example, they:

- release the parking brake
- shift the automatic transmission out of park position **P** or shift manual transmission into neutral
- start the engine

In addition, they may operate vehicle equipment and become trapped. There is a risk of an accident and injury.

When leaving the vehicle, always take the key with you and lock the vehicle. Never leave children unattended in the vehicle.

Applying the parking brake

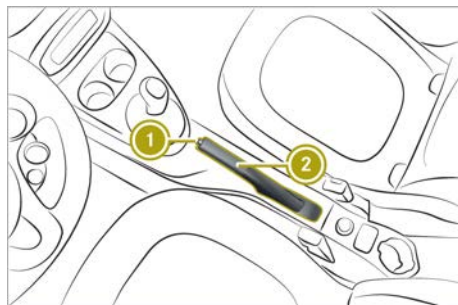

- ▶ Pull parking brake ② upwards.

The brake lights do not light up when you brake the vehicle with the parking brake.

Releasing the parking brake

- ▶ Depress the brake pedal and keep it depressed.
- ▶ Press release button ① on parking brake ② and move the parking brake down to the stop.

Hill start assist

WARNING

After a while, hill start assist no longer holds the vehicle and it may roll away. There is a risk of an accident and injury.

Therefore, quickly move your foot from the brake pedal to the accelerator pedal. Never leave the vehicle when it is held by hill start assist.

Hill start assist keeps the vehicle in place when driving uphill as soon as the brake pedal is released.

Hill start assist is only active in the following situations:

- when pulling away on an uphill slope
- when the parking brake is released
- **vehicles with automatic transmission:** the transmission is not in position **N**
- ESP® is functioning correctly.



- ▶ Release the brake pedal.
The vehicle is then held for about one second.
- ▶ Pull away.

Automatic start/stop system

Useful information

The automatic start/stop system automatically switches off the engine when the vehicle stops moving and starts it up again when pulling away. All vehicle systems except the air-conditioning system or automatic climate control continue to operate during automatic engine switch-off.

Indicator lamps of the automatic start/stop system

-  conditions fulfilled. The engine is switched off
-  conditions not fulfilled, the stop inhibitor is active. The engine will not stop automatically.

The engine stops automatically in the following situations:

- the automatic start/stop system is switched on
- under suitable outside temperatures
- the engine is at normal operating temperature
- the temperature in the vehicle interior has reached the set value
- the battery is charged
- the windscreen is not misted up (when the air conditioning is switched on)
- the doors and tailgate are closed
- the driver's seat belt is fastened
- reverse gear is not engaged

The engine starts automatically in the following situations:

- the automatic start/stop system is switched off
- the clutch pedal is depressed
- the brake is depressed
- the vehicle is rolling
- the temperature in the vehicle interior differs from the set temperature
- the tailgate is opened

- the windscreen is misted up
- the battery charge is too low

Switching off the engine automatically

Manual transmission

- ▶ Stop the vehicle.
- ▶ Select neutral.
- ▶ Release the clutch pedal.
The engine is switched off. The  indicator lamp lights up in the instrument cluster.

Automatic transmission

- ▶ Stop the vehicle in transmission position D or N, even when shifting manually.
The engine is switched off. The  indicator lamp lights up in the instrument cluster.

Starting the engine automatically

Manual transmission

- ▶ Depress the clutch pedal.

! **Vehicles with manual transmission:** only engage gear when the clutch pedal is depressed.

Automatic transmission

- ▶ Release the brake pedal.

Deactivating/activating the automatic start/stop system

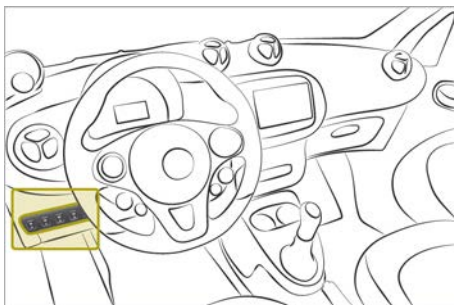

The automatic start/stop system is activated automatically when the engine is started.

- ▶ Press the  switch symbol.

On-board computer with colour display: the display shows a message. The indicator lamp lights up when the automatic start/stop system is deactivated or there is a malfunction.

Manual transmission

Shifting to neutral

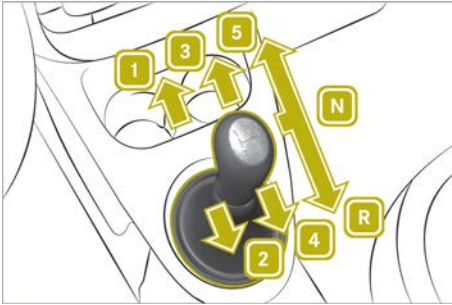

- ▶ Depress the clutch pedal fully.
- ▶ Move the gear lever to position **N**.

Engaging a gear

- ▶ Depress the clutch pedal fully.
- ▶ Engage a gear.

Engaging reverse gear

- ▶ **!** Only engage reverse gear with the engine at idling speed and the vehicle stationary. You could otherwise damage the manual transmission.

- ▶ Depress the clutch pedal fully.
- ▶ Select neutral.
- ▶ **smart66 kWturbo:** pull the sleeve on the gear lever upwards.
- ▶ Push the gear lever back to the right.

Automatic transmission

Please note

WARNING

If the engine speed is above the idling speed and you engage transmission position **D** or **R**, the vehicle could pull away suddenly. There is a risk of an accident.

When engaging transmission position **D** or **R**, always firmly depress the brake pedal and do not simultaneously accelerate.

WARNING

When the engine is switched off, the automatic transmission shifts into neutral position **N**. The vehicle may roll away. There is a risk of an accident.

Always shift to parking position **P** before switching off the engine. Secure the parked vehicle against rolling away by applying the parking brake.

In position **D**, the transmission automatically selects the gears based on the following criteria:

- selected drive program
- position of the accelerator pedal
- speed driven

Transmission position display

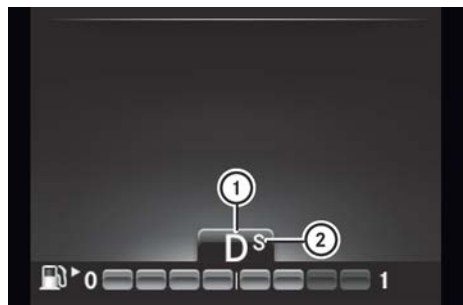

- ① Transmission position display
- ② Drive program display

The following transmission positions are available:

- **P** Park position
Park position secures a vehicle from rolling away when stationary, but should not be used as a parking brake.
Only shift to position P when the vehicle is stationary.
Apply the parking brake.
- **R** Reverse gear
Only shift to position R when the vehicle is stationary.
- **N** Neutral
No power is transmitted from the engine to the drive wheels.
Only shift to position N when the vehicle is stationary.
- **D** Drive
The automatic transmission changes gear automatically. All forward gears are available.

Changing the transmission position

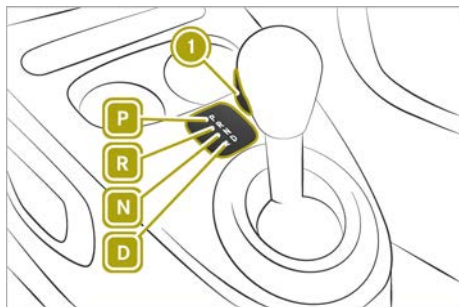

- P** Park position with parking lock
- R** Reverse gear
- N** Neutral
- D** Drive

The ignition must be switched on in order to shift the transmission to positions P, N or R. To shift the transmission from position P, you must also depress the brake pedal.

- ▶ Press release knob ①.
- ▶ Shift the selector lever to the desired transmission position.

Maximum acceleration (kickdown)

To reach maximum acceleration, use kick-down:

- ▶ Depress the accelerator pedal beyond the pressure point.
The transmission shifts to a lower gear depending on the engine speed.
- ▶ Ease off the accelerator pedal once the desired speed is reached.
The automatic transmission shifts to a higher gear.

Selecting drive programs

Two drive programs are available with different characteristics. The automatic transmission switches to drive program E every time the engine is started.

Drive program E (Comfort) is characterised by the following:

- comfortable driving style
- optimum fuel consumption through early upshifting
- driving at low engine speeds; the wheels are less likely to spin

Drive program S (Dynamic) is characterised by the following:

- dynamic, active driving style
- late upshifting
- possibly higher fuel consumption

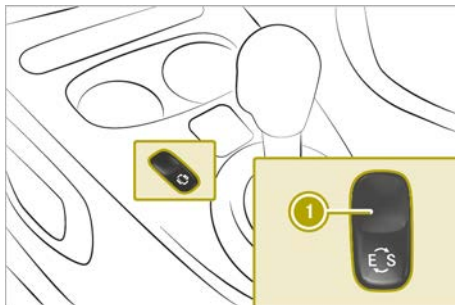

- ▶ Press program selector button ①.
The letter of the selected drive program appears in the display.

Changing gear manually

Useful information

On vehicles with an automatic transmission, you can shift gears manually using the selector lever or shift paddles. If it is permissible, the automatic transmission shifts to the next highest or next lowest gear.

When manual shifting is activated, the current gear is shown in the display.

Two options are available for manual shifting:

- permanent manual gearshifting
- short-term manual gearshifting (vehicles with Sports package)

Permanent manual gearshifting

Activating

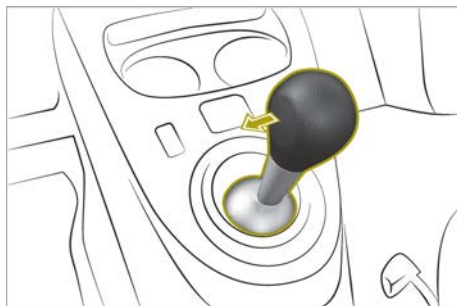

- Shift the gear selector lever to position D.
- Push the selector lever to the left.

Deactivating



- Push the selector lever to the right.

Short-term manual gearshifting (vehicles with Sports package)

Activating

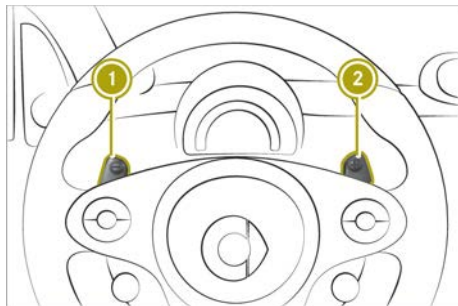

- Shift the gear selector lever to position D.
- Press shift paddle ① or ②.

The short-term setting remains active for a certain length of time. Under certain conditions this minimum amount of time is increased, e.g. when driving up a steep slope.

Deactivating

- Press and hold shift paddle ②.

Shifting with the selector lever

Shifting up



- Push the selector lever in the **+** direction.
The automatic transmission shifts up to the next gear.

Downshifting

- Push the selector lever in the **-** direction.
The automatic transmission shifts down to the next gear.

When coasting, the automatic transmission shifts down.

If the engine exceeds the maximum engine speed when shifting down, the automatic transmission protects against engine damage by not shifting down.

Shifting with shift paddles (vehicles with Sports package)

Shifting up

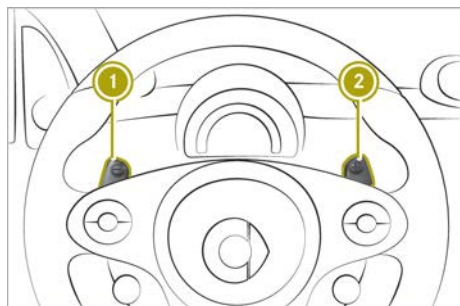

- ▶ Press shift paddle ②.
The automatic transmission shifts up to the next gear.

Downshifting

- ▶ Press shift paddle ①.
The automatic transmission shifts down to the next gear.

When coasting, the automatic transmission shifts down.

If the engine exceeds the maximum engine speed when shifting down, the automatic transmission protects against engine damage by not shifting down.

Using the turn signals

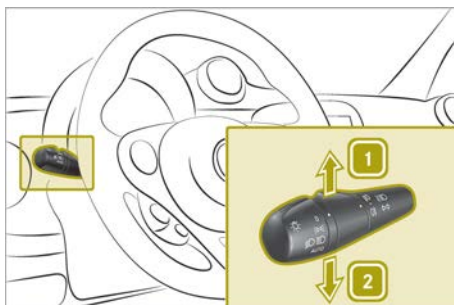

The ignition must be switched on in order to use the turn signals.

- ▶ To indicate: press the combination switch in the direction of arrow 1 (right) or 2 (left) past the point of resistance.
- ▶ To indicate briefly: press the combination switch briefly to the point of resistance. The turn signal flashes three times.

Driving economically

Notes on economical driving

🌱 Environmental note

CO₂ (carbon dioxide) is the gas which scientists believe to be principally responsible for global warming (the greenhouse effect). Your vehicle's CO₂ emissions are directly related to fuel consumption and therefore depend on:

- efficient use of the fuel by the engine
- driving style
- other non-technical factors, such as environmental influences, road conditions or traffic flow

You can minimise your vehicle's CO₂ emissions by driving carefully and having it serviced regularly.

Conservative driving and regular vehicle maintenance help minimise CO₂ emissions.

- 📌 Only for certain countries: you can find the current consumption and emission values of your vehicle in the COC docu-

ments (EU CERTIFICATE OF CONFORMITY). These documents are delivered with your vehicle.

The consumption figures were in each case based on the currently applicable version:

- for vehicles that comply with or exceed the EURO 5 standard, in accordance with Regulation (EC) No. 715/2007

Deviations from these values may occur under normal operating conditions.

Recommendations for driving economically:

- make sure the tyre pressures are correct.
- avoid unnecessary loads.
- warm up the engine while driving at low engine speeds.
- **vehicles with manual transmission:** change to a higher gear in good time.
- **vehicles with automatic transmission:** drive the vehicle in drive program E (Comfort).
- accelerate moderately.
- drive with care.
- release the accelerator pedal in good time.
- allow the vehicle to coast without using the brakes.
- have maintenance work carried out at the specified service intervals.



Environmental note

Avoid excessive engine speeds. This unnecessarily increases the fuel consumption of your vehicle and harms the environment as a result of increased emissions.

Monitoring the rev counter

Rev counter and dashboard clock

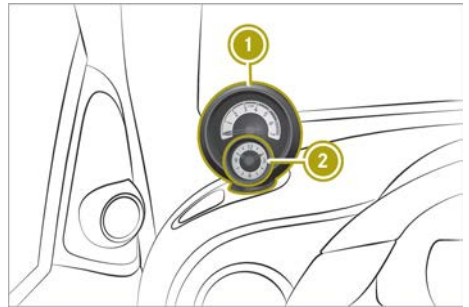

Rev counter ① with dashboard clock ② can be adjusted to the left or right.

Overrevving range

The overrevving range of the engine is shown with dashed lines in the orange marking of rev counter ①. The fuel supply is interrupted to protect the engine when the overrevving range is reached.

- ▶ Regularly check the engine speed while driving.
- ▶ If a high engine speed is displayed, shift up a gear.

Gearshift recommendations

The gearshift recommendations assist you in adopting an economical driving style.

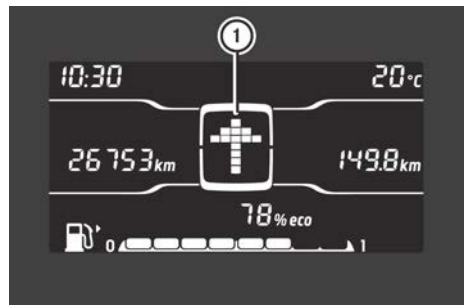

Monochrome display (manual transmission)

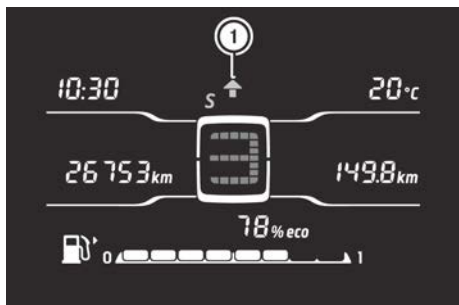

Monochrome display (automatic transmission, manual gearshifting)



Colour display (manual transmission)

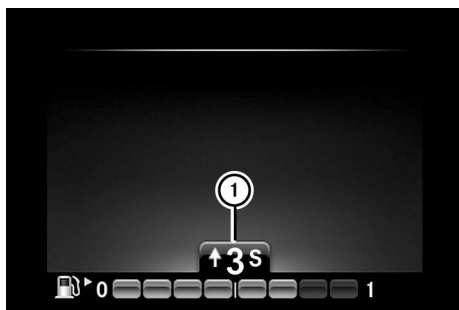

Colour display (automatic transmission, manual gearshifting)

- Depending on gearshift recommendation ①, shift up or down a gear.

Understanding the eco score display in the on-board computer

Useful information

The eco score display provides information on how to drive economically.

A higher percentage indicates a more economical driving style.

The percentage count in the eco score display only appears after covering a distance of approx. 400 m. If the ignition remains switched off for longer than 4 hours, the eco score display will be reset.

Monochrome display

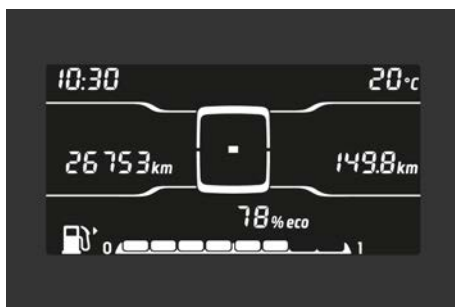

Colour display

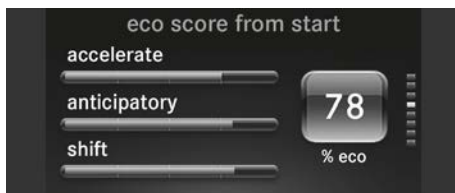

The percentage in the eco score display is calculated using the following categories:

- **accelerate:** the value increases with moderate acceleration.
- **anticipatory:** the value increases when unnecessary acceleration and deceleration is avoided.
- **Vehicles with manual transmission: shift:** the value increases when gearshift recommendations in the display are followed.

Using the eco score display in the smart Media-System

Calling up the eco score menu

- ▶ Select **Vehicle** > **eco score**.

Evaluating the current trip

- ▶ Select **Current trip**.
The following rating information and values appear:
 - Bar graphs for **accelerate**, **anticipatory** and **shift**
 - Distance covered
 - Total eco score as a percentage

Saving the current trip

- ▶ Select **Current trip** > **Save**.
- ▶ Select the category under which you want to save the trip.
The values for the current trip will be added to the category selected and the current trip will be reset. In the instrument cluster, the trip computer values will be returned to "From reset".

Comparing the current trip with the saved trips from a category

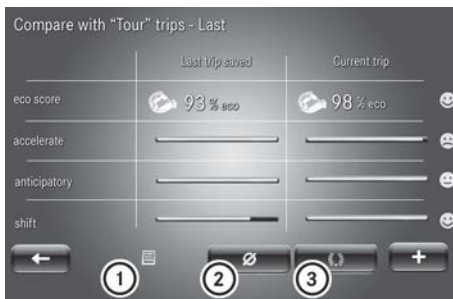

- ① Last trip saved in this category
- ② Average value for the category
- ③ Best trip in the category

- ▶ Select **Current trip** > **+** > **Compare**.
- ▶ Select category.
A comparison of the values for the current trip with the values of the selected category appears.
- ▶ Select the comparison value ①, ② or ③.
The current trip is compared to the respective comparison value from the category.

Resetting the current trip data

- ▶ Select **Current trip** > **Reset**.
- ▶ Select **Yes**.
In the instrument cluster, the trip computer values will be returned to "From reset".

Activating/deactivating eco score after a trip

- ▶ To activate: select **Current trip** > **+** > **Show eco score after trip**.
- ▶ To deactivate: select **Current trip** > **+** > **Hide eco score after trip**.

Displaying eco score for saved trips in a category

- ▶ Select **Vehicle** > **eco score** > **My preferred trips**.
- ▶ Select category.
eco score contains the following comparison values for each category:

- Summary
- Last value
- Average value
- Best value

The following types of evaluations are available for the **Last trip saved** category:

- Summary
- Detailed report

Renaming a category

At least one trip must be stored in the respective category.

- ▶ Select **Vehicle** > **eco score** > **My preferred trips** > **+** > **Rename this category**.

Resetting the eco score of one category

At least one trip must be stored in the respective category.

- ▶ Select **Vehicle** > **eco score** > **My preferred trips** >  > **Reset this category**.

Braking correctly

Please note

WARNING

The braking system can overheat if you leave your foot on the brake pedal while driving. This increases the braking distance and could even cause the braking system to fail. There is a risk of an accident.

Never use the brake pedal as a footrest. Do not simultaneously depress both the brake pedal and the accelerator pedal while driving.

WARNING

If you shift down on a slippery road surface in an attempt to increase the engine's braking effect, the drive wheels could lose their grip. This increases the risk of skidding and having an accident.

Do not shift down for additional engine braking on a slippery road surface.

Braking on steep downhill gradients

The engine's braking effect reduces the load on the brake system.

- ▶ On long and steep downhill gradients, downshift to a lower gear in good time.

Braking on wet road surfaces

There may be a delayed brake response when driving on wet roads, after driving through a car wash or after driving through deep water.

- ▶ Maintain a greater distance from the vehicle in front.
- ▶ Brake more firmly.

Braking on salt-treated roads

When driving on salt-treated roads, a layer of salt may form on the brake discs and pads. This increases the vehicle's braking distance.

- ▶ In order to prevent any salt build-up, apply the brakes occasionally while paying attention to the traffic conditions.
- ▶ Brake carefully at the end of the journey and when starting the next journey.
- ▶ Maintain a greater distance to the vehicle in front.

Driving on wet roads

Aquaplaning

Regardless of driving style and tyre tread depths, aquaplaning can occur on the road. Adapt your driving style as follows:

- ▶ Reduce the speed.
- ▶ Brake carefully.
- ▶ Avoid sudden steering movements
- ▶ Avoid tyre ruts.

Fording

 Bear in mind that vehicles travelling in front or in the opposite direction create waves. This may cause the maximum permissible water depth to be exceeded.

These notes must be observed under all circumstances. You could otherwise damage the engine, the electronics or the transmission.

Observe the following when driving through standing water:

- ▶ Do not drive through water that is higher than the lower edge of the vehicle body.
- ▶ Drive at walking pace.

Winter driving

WARNING

If you shift down on a slippery road surface in an attempt to increase the engine's braking effect, the drive wheels could lose their grip. This increases the risk of skidding and having an accident.

Do not shift down for additional engine braking on a slippery road surface.

DANGER

If the exhaust pipe is blocked or sufficient ventilation is not possible, poisonous exhaust gases such as carbon monoxide may enter the vehicle. This is the case, for example, if the vehicle gets stuck in snow. There is a risk of fatal injury.

If you have to leave the engine running, keep the exhaust pipe and the area around the vehicle free of snow. Open a window on the leeward side of the vehicle to ensure an adequate supply of fresh air.

- ▶ Before the start of winter, have the vehicle checked at a qualified specialist workshop.
- ▶ Use winter tyres and, if applicable, snow chains.
- ▶ Drive carefully and avoid sudden acceleration, turning and braking on slippery road surfaces.
- ▶ Do not use cruise control.
- ▶ If the vehicle skids, take corrective steering actions to counteract the movement.
- ▶ **Vehicles with automatic transmission:** if the vehicle skids, shift the transmission to position **N**.
- ▶ Do not use the outside temperature display as a way to determine if conditions are icy.
- ▶ Observe the road surface.

Lane Keeping Assist

Please note

WARNING

Lane Keeping Assist cannot always clearly identify lane markings.

In these cases, Lane Keeping Assist may:

- give an unnecessary warning
- not give a warning

There is a risk of an accident.

Always pay particular attention to the traffic situation and keep in lane, especially if Lane Keeping Assist alerts you.

WARNING

The Lane Keeping Assist warning does not return the vehicle to the original lane.

There is a risk of an accident.

Always steer, apply the brakes or accelerate the vehicle yourself, especially if Lane Keeping Assist alerts you.

Lane Keeping Assist issues an acoustic and visual warning when a vehicle unintentionally leaves the lane.

Lane Keeping Assist uses a camera which is located on the windscreen behind the rear-view mirror.

Lane Keeping Assist does not keep your vehicle in its lane. The driver is responsible for driving the vehicle in a safe manner and staying within the lane.

Lane Keeping Assist could be impaired or fail to respond under the following conditions:

- poor visibility
- strong glaring light
- dirty windscreen in the camera area
- unclear or broken lane markings
- very narrow and winding roads
- highly variable shade conditions on the road

When the turn signal is set, warnings are suppressed for a certain period of time.



No warning is given in the following situations:

- when crossing a lane marking quickly
- at speeds below 70 km/h

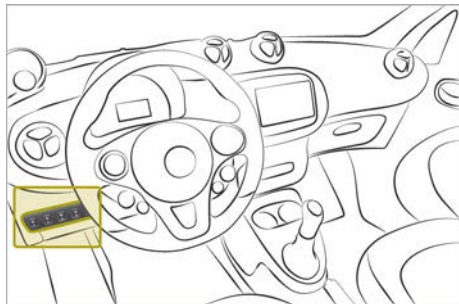
Activating and deactivating Lane Keeping Assist



- Press the  switch symbol. **On-board computer with colour display:** the display shows a message. The indicator lamp also lights up when Lane Keeping Assist is deactivated.

The  symbol appears in the display when Lane Keeping Assist is activated. At speeds above 70 km/h, Lane Keeping Assist is ready for use and the  symbol appears. On vehicles with a colour display, the  symbol lights up green.

Cruise control and limiter

Please note

WARNING

If you call up the stored speed and this differs from your current speed, the vehicle will accelerate. If you do not know the stored speed, the vehicle can accelerate unexpectedly. There is a risk of an accident.

Before you call up the stored speed, pay attention to traffic conditions. If you do not know the stored speed, store the desired speed again.

Cruise control is used in order to drive longer at a constant speed. The limiter helps to avoid exceeding a stored speed.

The driver is responsible for driving the vehicle in a safe manner, controlling the vehicle speed and braking in good time.

The two driver assist systems require the following:

- favourable weather and good visibility
- good road and traffic conditions

The cruise control and limiter systems do not brake automatically.

- Reduce the vehicle speed by applying the brakes.
- On long and steep downhill gradients, downshift to a lower gear in good time.

Cruise control is interrupted when the following occur:

- braking (including the parking brake)
- accelerating
- ESP® intervention

On an uphill gradient or when accelerating briefly, cruise control may interrupt speed regulation. Afterwards, the set speed is applied again.

On downhill slopes, the limiter can exceed the set speed. In this case, the stored speed flashes in the display and a warning tone sounds.



Cruise control is ready for use at speeds above 30 km/h. With the limiter, speeds of 30 km/h and over can be set as the maximum speed.

Cruise control and limiter cannot be activated at the same time.

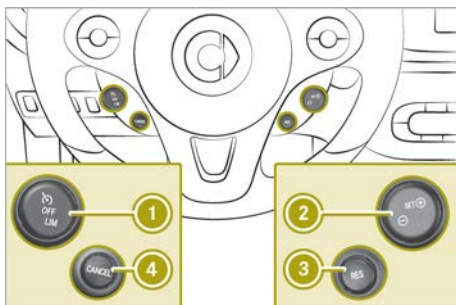

Activating cruise control or the limiter



- ▶ Press top (cruise control) or bottom (limiter) of button ①.

The  (cruise control) or  (limiter) button appears in the instrument cluster display.

Storing the current speed

- ▶ Press button ② ().
Limiter: the stored speed appears next to the  symbol in the instrument cluster display.
- ▶ **Cruise control:** release the accelerator pedal. The vehicle automatically maintains the stored speed. The stored speed appears next to the  symbol in the instrument cluster display.

If there is a change of drivers, inform the new driver of the speed stored.

Adjusting the stored speed

- ▶ Press (+) or (-) button ② repeatedly until the desired speed is reached.

Interrupting cruise control and the limiter



- ▶ Press button ④ ().
The stored speed can be accessed again later.

The stored speed is deleted when the engine is switched off.

Calling up the stored speed

- ▶ Press button ③ ().
- ▶ **Cruise control:** release the accelerator pedal.

Deactivating cruise control or the limiter

- ▶ Press button ① to OFF centre position. The  or  symbol in the instrument cluster display goes out. The stored speed is deleted.

The stored speed is deleted when the engine is switched off.

Refuelling

Refuelling notes

WARNING

Fuel is highly flammable. If you handle fuel incorrectly, there is a risk of fire and explosion.

You must avoid fire, naked flames, creating sparks and smoking. Switch off the engine and, if applicable, the auxiliary heating before refuelling.

WARNING

Fuels are poisonous and hazardous to health. There is a danger of injury.

Do not swallow fuel or let it come into contact with skin, eyes or clothing. Do not inhale fuel vapours. Keep fuels out of the reach of children.

If you or others come into contact with fuel, observe the following:

- Wash the fuel off any affected areas of skin with water and soap immediately.
- If you get fuel in your eyes, rinse them thoroughly with clean water immediately. Seek immediate medical attention.
- If fuel is swallowed, seek immediate medical attention. Do not induce vomiting.
- Change any clothing that has come into contact with fuel immediately.

! Do not use diesel to refuel vehicles with a petrol engine. Do not switch on the ignition if you accidentally refuel with the wrong fuel. Otherwise, the fuel will enter the fuel system. Even small amounts of the wrong fuel can result in damage to the fuel system and the engine. Notify a qualified specialist workshop and have the fuel tank and fuel lines drained completely.

! The BRABUS engine is designed for unleaded fuel with a minimum octane rat-

ing of 98 RON/88 MON. In countries where unleaded fuel with a minimum octane rating of 98 RON is not available, you can use unleaded fuel with an octane rating of 95 RON in emergencies. This may reduce engine performance and increase fuel consumption. When transporting a heavy load, using fuel with 95 RON may result in engine damage. smart recommends that you always operate your vehicle (petrol engine) with unleaded fuel which has a minimum octane rating of 98 RON/88 MON.

! Only refuel using unleaded petrol with at least 95 RON, which conforms to the European standard EN 228 or E DIN or an equivalent specification.

Fuel of this specification may contain up to 10% ethanol. Your vehicle is suitable for use with E10 fuel. You may refuel your vehicle using E10 fuel.

Fuel that does not conform to EN 228 can lead to increased wear as well as damage to the fuel system, engine and exhaust system.

! Only use the fuel recommended. Operating the vehicle with other fuels can lead to damage to the fuel system, engine and exhaust system.

! Operation of the engine with fuel additives added later can cause engine damage. Therefore, do not mix any fuel additives with the fuel. This does not include additives for the removal and prevention of residue build-up. Petrol must only be mixed with additives recommended by smart. Observe the instructions for use in the product description. For further information on recommended additives enquire at any smart centre.

! Use a filter when adding fuel from a fuel can. The fuel lines and/or the fuel injection system could otherwise be blocked by particles from the fuel can.

! Take care not to spill any fuel on painted surfaces. You could otherwise damage the paintwork.

For further information on fuel and fuel quality (▷ page 190).

The available fuel grade in some countries may be inadequate. In this case, add the rec-

ommended additives. Observe the notes and mixing ratios specified on the container.

For BRABUS vehicles: only refuel using unleaded super grade petrol with an octane rating of at least 98 RON/88 MON if you want maximum performance from the engine. In emergencies you can also use unleaded petrol with an octane rating of at least 95 RON/85 MON.

The arrow of symbol  shows the position of the fuel filler cap in the instrument cluster display.

Refuelling

WARNING

Electrostatic charge can cause sparks and thereby ignite fuel vapours. There is a risk of fire and explosion.

Always touch the vehicle body before opening the fuel filler flap or touching the fuel pump nozzle. This discharges any electrostatic charge that may have built up.

Do not get into the vehicle again during the refuelling process. There is a risk of creating an electrostatic charge.

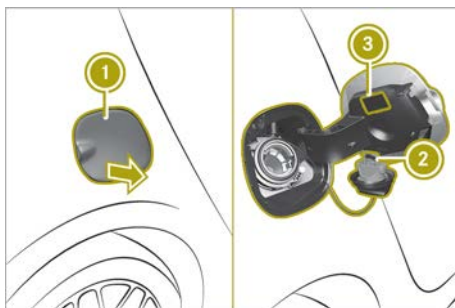

③ Fuel type instruction label

- ▶ Switch off the engine.
- ▶ Remove the key from the ignition lock.
- ▶ Open fuel filler flap ① in the direction of the arrow.
- ▶ Turn the fuel filler cap anti-clockwise and remove it from the filler neck.
- ▶ Hang the fuel filler cap on the hook on the inside of fuel filler flap ②.

- ▶ Insert the filler neck of the fuel pump nozzle all the way into the tank and refuel.
- ▶ Only fill the fuel tank until the pump nozzle switches off. The fuel may otherwise leak out. Overfilling the fuel tank can damage the fuel system.
- ▶ Replace the fuel filler cap on the filler neck and turn it clockwise.
- ▶ Close the fuel filler flap.

Switching on the lighting

Useful information

The driver must ensure that the light settings match the current weather, light and traffic conditions.

For reasons of safety, smart recommends that you drive with the lights switched on even during the daytime.

A warning tone sounds if the lights are still on when you leave the vehicle.

In some countries, operation of the headlamps varies due to legal requirements and self-imposed obligations.

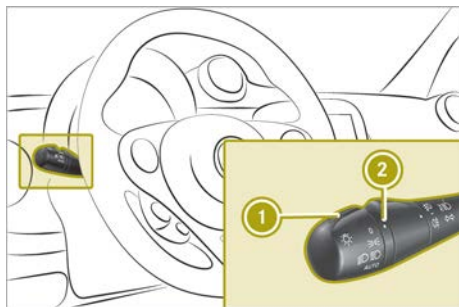

- ① Combination switch control
- ② Marking

Activating automatic headlamp mode

WARNING

When the light switch is set to **AUTO**, the dipped-beam headlamps may not be switched on automatically if there is fog, snow or other causes of poor visibility due to the weather conditions such as spray. There is a risk of an accident.

In such situations, turn the light switch to .

While the engine is running, the light setting is selected automatically according to the brightness of the ambient light. **AUTO** controls the daytime driving lights, side lamps and dipped-beam headlamps. The automatic headlamp feature is only an aid. The driver is responsible for the vehicle's lighting at all times.

- ▶ Turn combination switch control ① to the **AUTO** position.

The lights go out automatically in the following situations:

- The engine is switched off.
- The driver's door is opened.
- The vehicle is locked.
- The main-beam headlamps are not switched on when the vehicle is stationary.

Switching on the dipped-beam headlamps

- ▶ Turn combination switch control ① to the  position.

The  indicator lamp lights up in the instrument cluster.

Switching the main-beam headlamps on or off

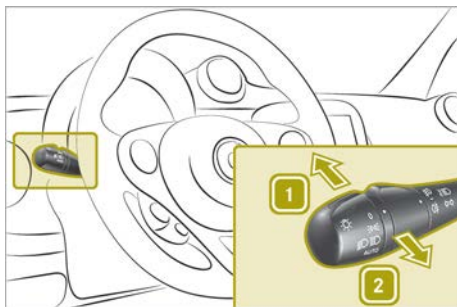

The engine must be running.

- ▶ Turn the combination switch control to the **AUTO** or  position.
- ▶ To switch on: press the combination switch in the direction of arrow 1.
- ▶ To switch off: move the combination switch back to its original position.

The  indicator lamp in the instrument cluster lights up when the main-beam headlamps are switched on.

Using the headlamp flasher

- ▶ Pull the combination switch in the direction of arrow **2**.

Switching on the side lamps

- ▶ Turn combination switch control **1** to the  position.

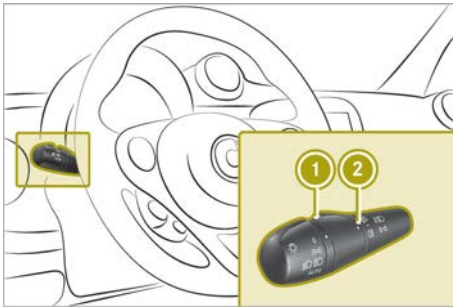

Switching on the foglamps and rear foglamps

Only vehicles with front foglamps have the "Foglamps" function.



- ① Combination switch middle ring
- ② Marking

The side lamps or dipped-beam headlamps must be switched on.

- ▶ Turn combination switch middle ring **1** to the desired marking:
 -  Foglamps
 -  Rear foglamp

After releasing, the combination switch middle ring returns automatically to the neutral position.

The foglamps and rear foglamps go out automatically in the following situations:

- the lights are switched off.
- the engine is switched off and the control is in the **AUTO** position.

Using the cornering light function

Only vehicles with front foglamps have the "Use cornering lights" function.

The cornering light function uses the front foglamps to improve the illumination of the road in the direction in which you are turning, enabling better visibility in tight bends, for example.

The following conditions must be fulfilled for the cornering light function to switch on automatically:

- The dipped-beam headlamps are switched on.
- The vehicle is moving at less than 40 km/h.
- The turn signal is switched on or the steering wheel is turned.

Adjusting the lighting

Adjusting the headlamp range

The vehicle load can affect the headlamp range. This can impair visibility, and the headlamps can dazzle oncoming traffic.

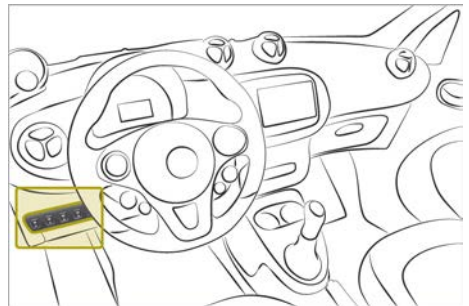

The ignition must be switched on in order to set the headlamp range.

- ▶ Turn the  headlamp range control to the position which corresponds to the load in your vehicle.
 - **0**: Driver's seat occupied or driver's seat and front-passenger seat occupied
 - **1**: Other loading

On-board computer with colour display: the display shows a message.

Adjusting the dipped-beam headlamps to left-hand and right-hand traffic

The symmetrical dipped-beam headlamps are required when travelling in countries where vehicles are driven on the opposite

side of the road to that in which the vehicle is registered. Unlike the asymmetrical dipped-beam headlamps, these headlamps do not dazzle oncoming traffic. Symmetrical dipped-beam headlamps provide less illumination to the edge of the carriageway.

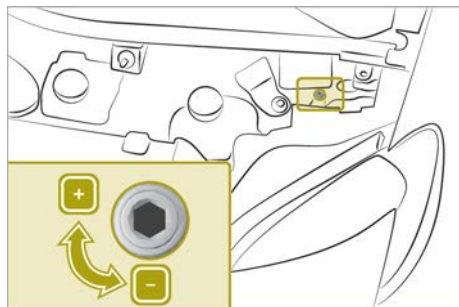

- ▶ Open the service cover.
- ▶ Turn the screws of both headlamps as far as they will go in the **-** direction for the symmetrical dipped-beam setting and in the **+** direction for the asymmetrical dipped-beam setting.
- ▶ Have the dipped-beam headlamp setting checked at a qualified specialist workshop.

>> Ensuring good visibility.

Using the interior lighting

Switching the interior lighting on and off

The interior lights go on when you unlock the doors.

The interior lights switch off in the following situations:

- A door is opened and 15 minutes have passed.
- All doors are closed, the vehicle has been locked and 15 seconds have passed.
- All doors are closed, the vehicle has not been locked and 4 minutes have passed.
- The engine has been started.

The interior lighting can be activated when a door is open. After closing the doors, the interior lighting goes out.

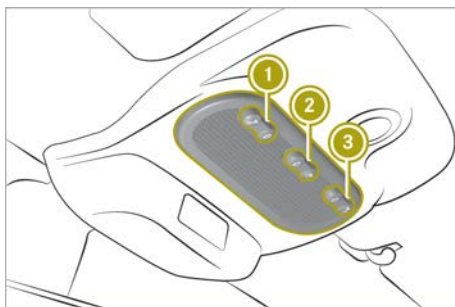

- ▶ Press switch **①** to activate or deactivate the left-hand reading lamp.
- ▶ Move switch **②** to the desired position:
 - interior lighting switched on
 - interior lighting controlled automatically
 - interior lighting switched off
- ▶ Press switch **③** to activate or deactivate the right-hand reading lamp.

Adjusting the ambient lighting (colour display)

On-board computer with colour display: the ambient lighting is set in the on-board computer (▷ page 92).

Using the windscreen wipers

Switching on the windscreen wipers

Please note

! Do not operate the windscreen wipers when the windscreen is dry, as this could damage the wiper blades. Moreover, dust that has collected on the windscreen can scratch the glass if wiping takes place when the windscreen is dry.

If it is necessary to switch on the windscreen wipers in dry weather conditions, always operate them using washer fluid.

! Vehicles with a rain sensor: if the windscreen becomes dirty in dry weather conditions, the windscreen wipers may be activated inadvertently. This could damage the windscreen wiper blades or scratch the windscreen.

For this reason, you should always switch off the windscreen wipers in dry weather.

- ❗ Make sure that the windscreen wipers are free of ice. Otherwise the wiper motor may overheat.

Wiper blades are subject to wear and tear. smart recommends replacing the wiper blades twice a year. Worn or damaged wiper blades cause smearing on the windscreen. On vehicles with a rain sensor, malfunctions are then possible.

Switching continuous wipe on and off

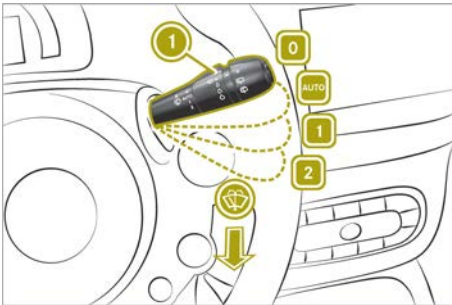

① Control for wipe frequency

To operate the windscreen wiper, the ignition must be switched on.

- ▶ Press the combination switch down or up to the desired position:
 - 1 Continuous wipe, slow
 - 2 Continuous wipe, fast

In position 2, the wipe frequency is reduced if the engine is switched off automatically.

In position 1 or in the  position, the windscreen wipers switch off when the engine is switched off automatically and the driver's door is opened.

Automatic wipe (vehicles with rain sensor)

The rain sensor is only an aid. The driver is responsible for ensuring good visibility at all times.

- ▶ Press the combination switch to the **AUTO** position. In automatic wipe mode, the appropriate wiping frequency is set according to the intensity of the rain.
- ▶ Use control ① to set the wipe frequency.

Switching on intermittent wiping

- ▶ Press the combination switch to the **AUTO** position.
- ▶ Use control ① to set the wipe frequency.



Wiping with washer fluid

- ▶ Pull the combination switch in the direction of arrow .

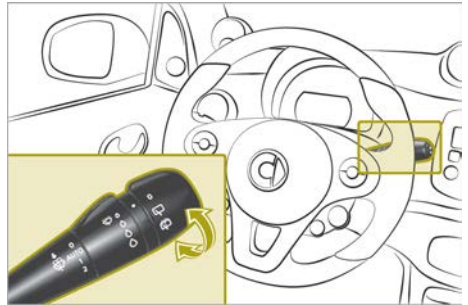
Switching the rear window wiper on and off (smart fortwo coupé)



To operate the rear window wiper, the ignition must be switched on.

- ▶ Turn the outer control on the combination switch to the desired position:
 - 0 Rear window wiper off
 -  Rear window wiper on
 -  Wiper with washer fluid

Switching the rear window wiper on and off when in reverse gear (smart fortwo coupé)

You can switch the "Automatic rear window wiper when reversing" setting on or off in the smart Media-System. This setting briefly operates the rear window wiper automatically when the ignition and the windscreen wipers are switched on and reverse gear is engaged.

- ▶ In the smart Media-System, select **Vehicle > Settings > Auto rear wipe with reverse gear**. The selected setting is highlighted.
- ▶ Confirm the setting with **Done**.

Folding the sun visor to the side

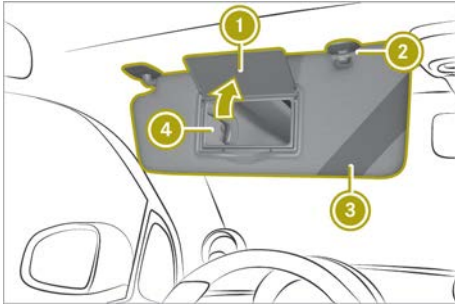

- ① Mirror cover
- ② Bracket
- ③ Retaining strap
- ④ Vanity mirror

- ▶ Fold the sun visor down.
- ▶ Pull the sun visor out of retainer ②.
- ▶ Fold the sun visor to one side

>> Ensuring good visibility.

Locking and unlocking the doors from the inside

Using the door handle to unlock the door

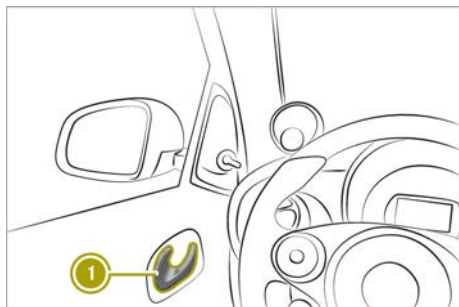

- ▶ Pull door handle ①.

If the vehicle has previously been locked with the key, opening a door from the inside will trigger the anti-theft alarm system. To disable the alarm, switch on the ignition.

Centrally locking and unlocking the vehicle from the inside

WARNING

If children are left unsupervised in the vehicle, they could:

- open doors, thereby endangering other persons or road users
- get out and be struck by oncoming traffic
- operate vehicle equipment and become trapped, for example

In addition, the children could also set the vehicle in motion, for example, if they:

- release the parking brake
- shift the automatic transmission out of park position P or shift manual transmission into neutral
- start the engine

There is a risk of an accident and injury.

When leaving the vehicle, always take the key with you and lock the vehicle. Never leave children and animals unattended in

the vehicle. Keep the keys out of the reach of children.

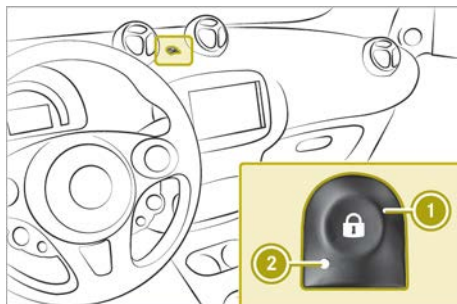

- ▶ To lock: press button ①.
When the doors are locked, indicator lamp ② lights up.
- ▶ To unlock: press button ①.

Activating and deactivating the automatic locking feature

The activated automatic locking feature locks the vehicle automatically when the ignition is switched on and the vehicle is moving.

- ▶ When the engine is running, press and hold button ① for 5 seconds until a tone sounds.
When the automatic locking function is activated, the locking mechanism engages audibly when you pull away. When the automatic locking function is deactivated, no sound occurs.

Activating the double-lock function

For England only: the double-lock function prevents the doors from being opened from the inside.

WARNING

When the double locks are activated, the doors can no longer be opened from the inside. People in the vehicle can no longer get out, e.g. in hazardous situations. There is a risk of injury.

Therefore, do not leave any people unsupervised in the vehicle, particularly children, elderly people or people in need of special assistance. Do not activate the double lock when people are in the vehicle.

WARNING

If persons (particularly children) are exposed to heat or cold for a prolonged period, there is a risk of serious or even fatal injuries. Never leave persons (particularly children) unattended in the vehicle.

- ▶ Press button  twice.
The double-lock function is enabled.

Understanding the reversing function

The side windows are equipped with an automatic reversing feature. If a solid object blocks or restricts a side window from closing during automatic operation, the side window opens again automatically. During the manual closing process, the side window only opens again automatically after the corresponding switch is released. The automatic reversing feature is only an aid. The driver is responsible for operating the side windows safely.

WARNING

The reversing function does not react:

- to soft, light and thin objects, e.g. small fingers
- while resetting

This means that the reversing feature cannot prevent someone being trapped in these situations. There is a risk of injury.

When closing, make sure that no parts of the body are in the closing area. If someone becomes trapped, press the switch to open the side window again.

Opening and closing the windows

Please note

WARNING

While closing the side windows, body parts in the closing area could become trapped. There is a risk of injury.

When closing make sure that no parts of the body are in the closing area. If somebody becomes trapped, release the switch or press the switch to open the side window again.

WARNING

Children could become trapped if they operate the side windows, particularly when unattended. There is a risk of injury.

When leaving the vehicle, always take the key with you and lock the vehicle. Never leave children unattended in the vehicle.

WARNING

If you close a side window again immediately after it has been blocked or reset, the side window closes with increased or maximum force. The reversing function is then not active. Parts of the body could be trapped in the closing area in the process. This poses an increased risk of injury or even fatal injury.

Make sure that no parts of the body are in the closing area. To stop the closing process, release the switch or push the switch again to reopen the side window.

The switches for both side windows are located on the driver's door. There is also a switch for the front-passenger window on the front-passenger door. The switch on the driver's door takes precedence.

Opening and closing the windows

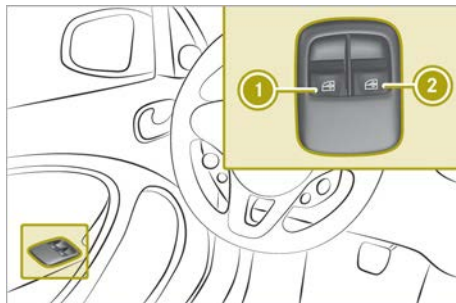

① Left side window

② Right side window

- ▶ To open: press the switch.
- ▶ To close: pull the switch.

Opening and closing windows fully in automatic mode

- ▶ To open the windows fully, press the switch beyond the point of resistance and release it.
- ▶ To close the windows fully, pull the switch beyond the point of resistance and release it.
- ▶ To stop automatic operation, press the switch again.

Using the soft top (smart fortwo cabrio)

Please note

WARNING

During opening and closing of the folding top or rear soft top, body parts may become trapped for example, by the roof mechanical system. There is a risk of injury.

Ensure that no parts of the body are in the immediate vicinity of moving parts during the closing or opening process. Release the switch immediately if somebody becomes trapped.

- !** When transporting long objects in the vehicle interior, make sure that these do

not press against the folding roof when it is closed.

When transporting objects that extend beyond the rear, make sure that these do not rest on the rear soft top fasteners (brackets). During loading, make sure that objects with sharp edges do not come into contact with the soft top or the rear window.

If the rear soft top is lowered, do not distribute a weight in excess of 75 kg on top of it.

Make sure that the third brake lamp is not covered.

- !** Make sure that the lock openings of the soft-top system are not blocked. Stow the side spars only in the intended stowage compartment in the tailgate.

- !** Make sure that objects in the luggage compartment are not stacked too high. They could otherwise be damaged when the rear soft top is opened or closed.

The procedure for removing, fitting and stowing the side bars is described below. The QR code is a link to a video clip that demonstrates the procedure.



Opening and closing the soft top

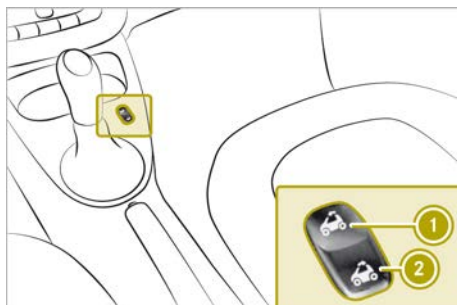

To open or close the soft top, the ignition must be switched on.

- ▶ To open: press the switch to position ② until the soft top is in the desired position. Press switch ② again to fully open the soft top.
- ▶ To close: press the switch to position ① until the soft top is in the desired position.

It is possible to open or close the soft top while driving up to the maximum design speed. In poor weather and at high speeds, it is possible that electric locking when closing is not reliable. If this is the case you must reduce the speed and, if necessary, press the switch again to close the soft top.

Removing the side bars

- ▶ Open the soft top
- ▶ Open the doors and tailgate.

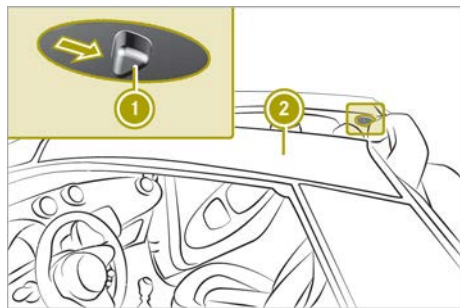

- ▶ To release: slide lever ① back. The side bar is unlocked.
- ▶ Push lever ① back again and remove side bars ②.

Stowing the side bars

⚠ WARNING

If you transport the side bars without securing them, they may be thrown around in the event of an accident, braking or sudden changes in direction. There is a risk of injury.

Always stow the side bars in the designated stowage well and close the stowage well lid.

⚠ When the rear soft top is lowered, the side support beams could be stolen. Therefore, remove the side support beams and stow them in the luggage compartment or close the soft top.

⚠ If you load the stowage space it could be damaged.

Never stow heavy objects on the stowage space or sit on it.

Please note:

- only use the stowage space to store the side bars
- always place both side bars in the stowage space

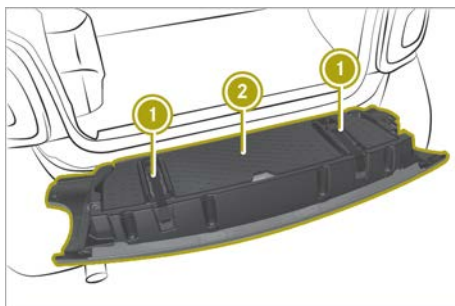

Observe the notice on the stowage space.

- ▶ Release fastening straps ① on the stowage space and guide the locking mechanism with your hand until the fastening straps are released.
- ▶ Open cover ②.
- ▶ Store the side bars as shown (observe markings L and R on the side bars and the stowage compartment for the left and right side bars):

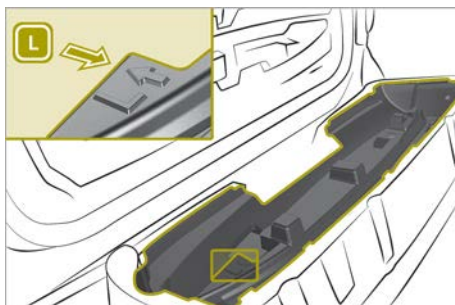

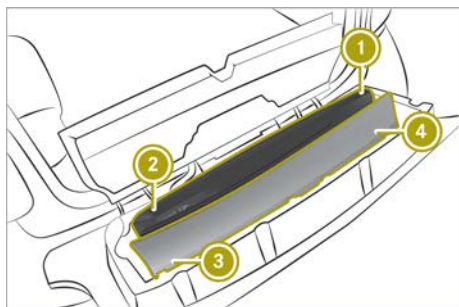

- ① Side bar, front left
- ② Side bar, rear left
- ③ Side bar, front right
- ④ Side bar, rear right

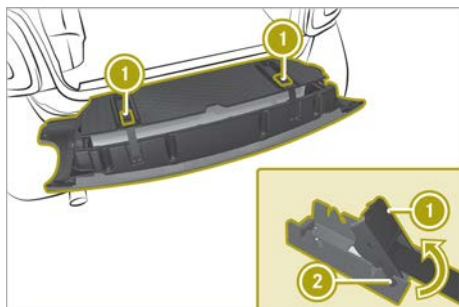

- ▶ Close the cover.
The cover must audibly engage.
- ▶ Secure both fastening straps with tensioner ① on rear detent ②.
The red surfaces at the side must no longer be visible. An audible click can be heard upon engaging.
- ▶ Close the tailgate.
- ▶ If the tailgate does not close properly, check if the side bars have been stored as specified.

Fitting the side bars

⚠ WARNING

If the side bars are incorrectly mounted they may become loose during the journey and endanger other road users. There is a risk of accident and injury.

Mount the side bars as described.

- ▶ Open the doors and tailgate.
- ▶ Release the fastening straps on the stowage space and guide the locking mechanism with your hand until the fastening straps are released.
- ▶ Open the cover.
- ▶ Remove the side bars.

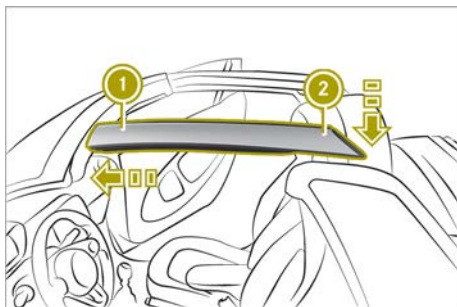

- ▶ Insert the side bar from the stowage compartment marked L on the left side at the front end ①.
- ▶ Press down rear end of side bar ② until it engages twice.
- ▶ Fit the side bar from the stowage compartment marked R on the right-hand side.

Closing the stowage space without the side bars

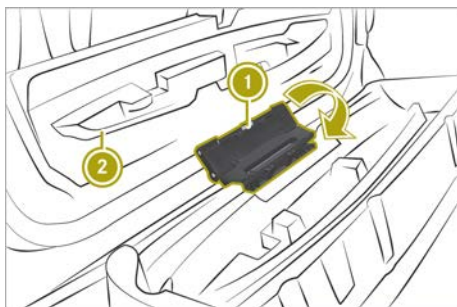

- ▶ Move folding mechanism ① in the direction of the arrow.
- ▶ Close cover ②.

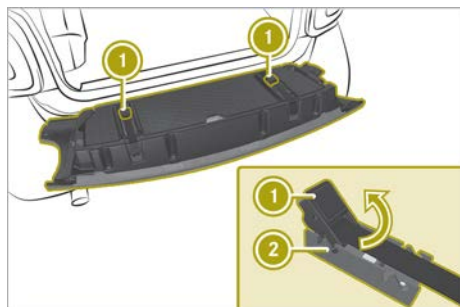

- ▶ Secure both fastening straps with tensioner ① on front detent ②. The red surfaces at the side must no longer be visible. An audible click can be heard upon engaging.
- ▶ Close the tailgate.

Operating the climate control system

Useful information

The climate control system is only available when the engine is running.

If the climate control system is deactivated, the air supply and circulation are switched off. The windows could mist up. You should therefore switch off the climate control system for brief periods only.

In air-recirculation mode, only the air inside the vehicle is recirculated and no fresh air is introduced. This is useful in a tunnel or when there are unpleasant odours outside the vehicle. In air-recirculation mode, the windows may mist up more quickly, particularly when the outside temperature is low. Therefore, switch on air-recirculation mode only briefly.

If the automatic start/stop system switches the engine off, the air inside the vehicle will not be air-conditioned or dehumidified. The windows can mist up more quickly. If the windows mist up, deactivate the automatic start/stop system. The engine starts again.

The integrated filter in the climate control system keeps out most particles of dust as well as pollen. The filter reduces the amount of air supplied to the vehicle interior. For this reason, you should always observe the interval for replacing the filter.

Operating the heating and air-conditioning

Switching on and off

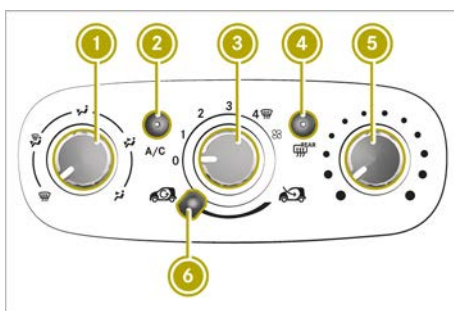

The engine must be running in order to operate the heating and air-conditioning system.

- ▶ To switch on: turn control ③ clockwise.
- ▶ To switch off: turn control ③ to position 0.

Setting the temperature

- ▶ Turn control ⑤ in small increments clockwise or anti-clockwise.

Setting the air distribution

- ▶ Turn control ① to the desired position:
 - Demister vents
 - Demister vents and footwell vents
 - Footwell vents
 - Centre, side and footwell vents
 - Centre and side air vents

Increasing or decreasing the blower speed

- ▶ Turn control ④ clockwise or anti-clockwise.

Activating/deactivating air-recirculation mode

- ▶ To switch on: slide control ⑥ to the left to the position.
- ▶ To switch off: slide control ⑥ to the right to the position.

Switching "Cooling with air dehumidification" on or off

The "Cooling with air dehumidification" function cools and dehumidifies the air inside the vehicle during warm weather.

The engine must be running in order to use "Cooling with air dehumidification".

- ▶ Press button ②.

In damp weather, switch off the "Cooling with air dehumidification" only briefly, otherwise the windows will mist up faster.

Demisting the windscreen

- ▶ Turn control ① to the  position.
- ▶ Turn control ③ to position 4.
- ▶ Turn control ⑤ clockwise as far as it will go.
- ▶ Slide control ⑥ to the right.

Use this setting only until the windscreen is clear again.

Demisting the rear window

When the rear window heating is activated, the exterior mirrors are also heated.

- ▶ Press button ④.
The indicator lamp in the button is lit when the rear window heating is activated.

Use this setting only until the rear window is clear again.

Drying windows that are misted up on the inside

- ▶ Press button ②.
- ▶ If the windows continue to mist up, turn control ① to .

Use this setting only until the windows are clear again.

Drying windows that are misted up on the outside

- ▶ Switch on the windscreen wipers.
- ▶ Turn control ① to .

Use this setting only until the windows are clear again.

Operating the automatic climate control

Switching on and off

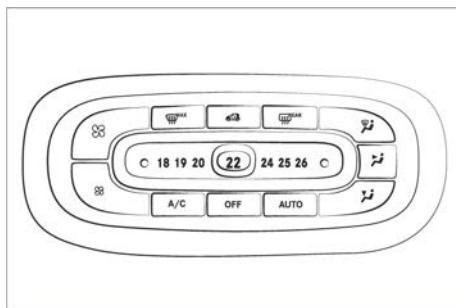

The engine must be running in order to operate the automatic climate control system.







- ▶ To switch on: press the **AUTO** button. The indicator lamps below **AUTO** and **A/C** light up.
- ▶ To deactivate: press the **OFF** button. The indicator lamp below **OFF** lights up.

Setting the temperature

- ▶ Move the slider in small increments to the left or right.

In automatic mode, the set temperature is maintained at a constant level. The air distribution and blower speed are regulated automatically.

Switching the air distribution on and off

- ▶ Press one or more of the , ,  buttons.
 -  Demister vents
 -  Centre and side air vents
 -  Footwell vents



Increasing the blower speed

- ▶ Press the  button.

Decreasing the blower speed

- ▶ Press the  button.



Activating/deactivating air-recirculation mode

- ▶ Press the  button.
The indicator lamp below  lights up when air-recirculation mode is activated.

Switching "Cooling with air dehumidification" on or off



The "Cooling with air dehumidification" function cools and dehumidifies the air inside the vehicle during warm weather.

The engine must be running in order to use "Cooling with air dehumidification".

- ▶ To switch on: press the  and  button.
The indicator lamp below  lights up when the function is activated.

In damp weather switch off the "Cooling with air dehumidification" function only briefly, otherwise the windows will mist up faster.



Demisting the windscreen

- ▶ Press the  button.
The indicator lamp below  lights up when the windscreen is demisted.

Use this setting only until the windscreen is clear again.



Demisting the rear window

When the rear window heating is activated, the exterior mirrors are also heated.

- ▶ Press the  button.
The indicator lamp below  lights up when the rear window heating is activated.

Use this setting only until the rear window is clear again.

Drying windows that are misted up on the inside

- ▶ Press the  button.
- ▶ Press the  button.
- ▶ If the windows are still misted up, press the  button.

Use this setting only until the windows are clear again.

Drying windows that are misted up on the outside

- ▶ Switch on the windscreen wipers.
- ▶ Press the  button.

Use this setting only until the windows are clear again.

Adjusting the air vents

Please note

WARNING

Very hot or very cold air can flow from the air vents. This could result in burns or frostbite in the immediate vicinity of the air vents. There is a risk of injury.

Make sure that all vehicle occupants always maintain a sufficient distance to the air outlets. If necessary, redirect the airflow to another area of the vehicle interior.

WARNING

If you pour cleaning fluid or disinfectant into the vehicle's ventilation system, it may ignite. There is a risk of fire.

Never spray these or other agents into the ventilation system. Always have work on the ventilation system carried out at a qualified specialist workshop.

Keep the following rules in mind for optimal climate control:

- Keep the air slots between the service cover and windscreen clear of blockages.
- Do not cover the vents or ventilation grilles in the vehicle interior.
- Open the air vents fully.

Opening and closing the air vents

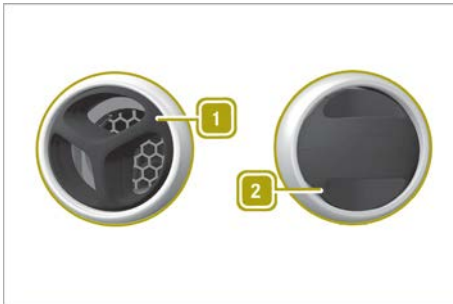

- ▶ To open **1**: turn the vent outwards.
- ▶ To close **2**: turn the vent inwards.

Directing the air vents

- ▶ Turn the air vents upwards, downwards, to the left or to the right as desired.

Switching the seat heating on and off

WARNING

If you repeatedly switch on seat heating, the seat cushion and backrest padding may become very hot. The health of vehicle occupants with limited temperature sensitivity or a limited ability to react to excessively high temperatures may be affected or they may even suffer burn-like injuries. There is a risk of injury.

Therefore, do not switch on the seat heating repeatedly.

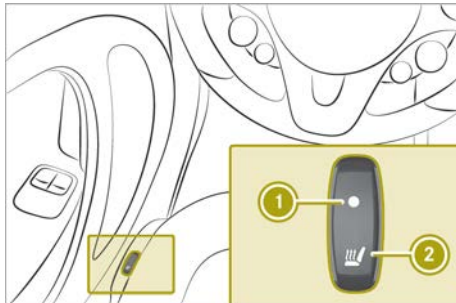

The seat heating only works when the ignition is switched on.

- ▶ Press button **2**.
Indicator lamp **1** lights up when seat heating is activated.

The seat heating switches off automatically after about 10 minutes.

Using the accessories

Using the cigarette lighter

WARNING

You can burn yourself if you touch the hot heating element or the socket of the cigarette lighter.

In addition, flammable materials can ignite if:

- the hot cigarette lighter falls
- a child holds the hot cigarette lighter to objects, for example

There is a risk of fire and injury.

Always hold the cigarette lighter by the knob. Always make sure that the cigarette lighter is out of reach of children. Never leave children unattended in the vehicle.

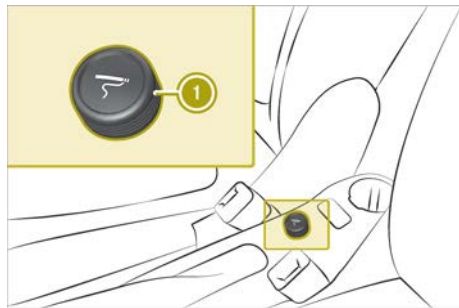

The cigarette lighter only works when the ignition is switched on.

- ▶ Press cigarette lighter **1**.
When cigarette lighter **1** is hot, it pops up automatically.

Using the ash tray

- !** The cup holder in the centre console is not heat resistant. Before placing lit cigarettes in the ashtray, make sure that the

ashtray is fully inserted in the cup holder. Make sure that lit cigarettes do not fall into the cup holder.

Otherwise, the cup holder could be damaged.



- ▶ To open: lift up cover ①.
- ▶ To close: push down cover ①.
- ▶ To remove: pull the ashtray up and out.
- ▶ To insert: insert the ashtray into the cup holder.

Using the 12 V socket

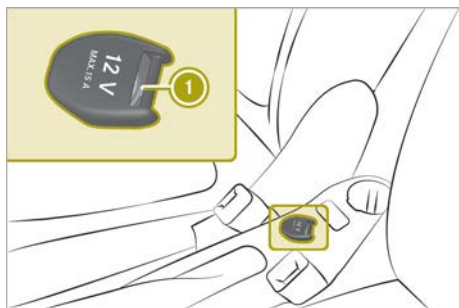

- ▶ Turn the key in the ignition lock to position 1.
- ▶ Lift up the cover of socket ①.
- ▶ Connect device.

The socket can be used for accessories up to a maximum draw of 120 W (15 A).

If you use the socket for very long periods when the engine is switched off, the 12 V battery may discharge.

Fitting and removing the floor mats

⚠ WARNING

Objects in the driver's footwell may restrict the clearance around the pedals or block a depressed pedal. This jeopardises the operating and road safety of the vehicle. There is a risk of an accident.

Stow all objects securely in the vehicle so that they do not get into the driver's footwell. Always fit the floor mats securely and as prescribed in order to ensure that there is always sufficient room for the pedals. Do not use loose floor mats and do not place several floor mats on top of one another.

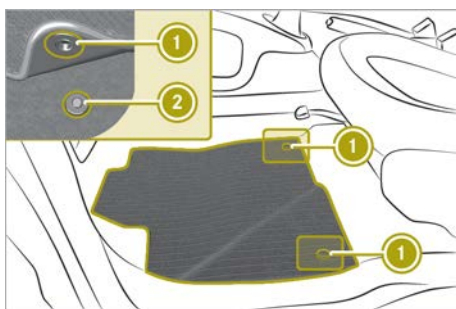

- ▶ Slide the driver's seat backwards.
- ▶ To install: press securing knobs ① onto retainers ②.
- ▶ To remove: release securing knobs ① from retainers ②.

Parking

Please note

WARNING

Flammable material such as leaves, grass or twigs may ignite if they come into contact with hot parts of the exhaust system or exhaust gas flow. There is a risk of fire.

Park the vehicle so that no flammable material can come into contact with hot vehicle components. In particular, do not park on dry grassland or harvested grain fields.

WARNING

If you leave children unattended in the vehicle, they may be able to set the vehicle in motion if, for example, they:

- release the parking brake
- shift the automatic transmission out of park position **P** or shift manual transmission into neutral
- start the engine

In addition, they may operate vehicle equipment and become trapped. There is a risk of an accident and injury.

When leaving the vehicle, always take the key with you and lock the vehicle. Never leave children unattended in the vehicle.

WARNING

When the engine is switched off, the automatic transmission shifts into neutral position **N**. The vehicle may roll away. There is a risk of an accident.

Always shift to parking position **P** before switching off the engine. Secure the parked vehicle against rolling away by applying the parking brake.

-  Always secure the vehicle correctly against rolling away. Otherwise, the vehicle or its drivetrain could be damaged.

Switching off the engine

- ▶ Apply the parking brake.
- ▶ **Manual transmission:** engage first or reverse gear.
- ▶ **Automatic transmission:** shift the transmission to position **P**.
- ▶ Turn key to position 0 in the ignition lock and remove it.
- ▶ On steep uphill or downhill gradients, turn the front wheels towards the kerb.

Using the parking aid

Useful information

-  Pay attention to people and obstacles when manoeuvring or parking the car. The driver is responsible in these situations.

The electronic parking aid gives an acoustic indication of the distance between the vehicle and an obstacle behind it.

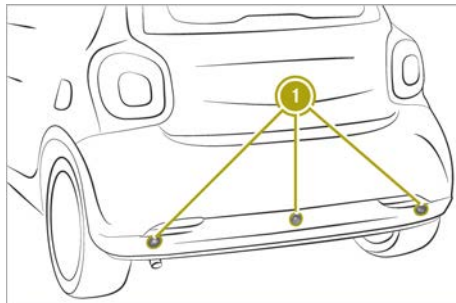

The parking aid uses three sensors (1) in the rear bumper to monitor the area around the vehicle.

The parking aid measures the distance between the vehicle and an obstacle. If the proximity to the object behind the vehicle is less than 1.20 m, a short signal is issued. If the object is less than 30 cm away, a continuous warning tone is issued.

The parking aid might not function correctly under the following circumstances:

- on uneven terrain
- if there are obstacles below or above the sensor detection range

- near snow or objects that absorb ultrasonic waves
- close to sources of strong ultrasonic radiation, such as pneumatic drills

If you engage reverse gear while the engine is running, the parking aid is activated.

Deactivating/activating the parking aid

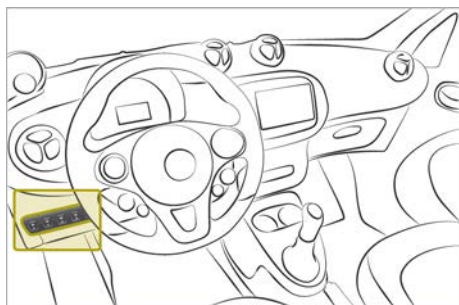

- ▶ Press the  switch symbol. The indicator lamp lights up when the parking aid is deactivated.

Using the reversing camera

Useful information

- ⚠ Pay attention to people and obstacles when manoeuvring or parking the car. The driver is responsible in these situations.
- ⚠ If the rear of your vehicle is damaged, consult a qualified specialist workshop and have the reversing camera checked.

The reversing camera is a visual parking and manoeuvring aid. It shows the area behind your vehicle with guide lines in the smart Media-System display.

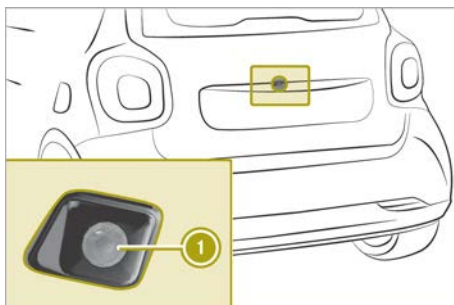

Reversing camera ① is located above the licence plate in the tailgate.

The area behind the vehicle is displayed as a mirror image in the smart Media-System display.

The reversing camera might show a distorted view of obstacles or show them incorrectly or not at all if:

- the obstacle is very close to the rear bumper
- the obstacle is underneath the rear bumper
- the obstacle is close to the tailgate handle
- the reversing camera is covered by additional accessories, e.g. a bicycle rack

The function of the reversing camera might be limited:

- if the tailgate is open
- if there is snow or heavy rain
- in the dark
- if a very bright light outshines the camera
- if there is fluorescent light, e.g. from fluorescent lamps or LED lighting
- if there is a rapid change of temperature
- if the camera lens is dirty

Guide lines in the display

Useful information

- ⚠ Objects that are not at ground level appear further away than they actually are, for example:
 - the bumper of the vehicle parked behind
 - the drawbar of a trailer
 - the ball coupling of a trailer tow hitch

- the tail-end of a lorry
- slanted posts

Only use the image from the reversing camera as a guide. You may otherwise damage your vehicle and/or the object.

Guide lines in different colours show the distance of obstacles from the rear of the vehicle. Static guide lines do not change when the steering wheel is turned. Dynamic guide lines change depending on the position of the steering wheel.

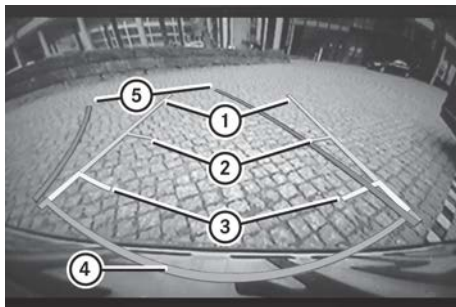

- ① Static: vehicle width including exterior mirrors
- ② Green, static: approx. 1.50 m
- ③ Yellow, static: approx. 0.7 m
- ④ Red, static: approx. 0.3 m
- ⑤ Blue, dynamic: vehicle width including exterior mirrors

The distance specifications only apply to objects that are at ground level.

Activating the reversing camera

The ignition must be switched on to use the reversing camera.

- ▶ In the smart Media-System, select **Vehicle** > **Settings** > **Rear camera** > **Rear camera view settings** > **Rear camera view**.
- ▶ Confirm with **Done**.
- ▶ Engage reverse gear.
The area behind the vehicle is shown with guide lines in the smart Media-System display.

Switching off the reversing camera

After driving forwards briefly, the reversing camera will turn itself off.

Adjusting the reversing camera settings

- ▶ In the smart Media-System, select **Vehicle** > **Settings** > **Rear camera** > **Rear camera view settings**.
- ▶ To select the desired settings:
 - Switch **Rear camera view** on or off.
 - Switch **Static guidelines** on or off.
 - Switch **Dynamic guidelines** on or off.
- ▶ Confirm with **Done**.

Adjusting reversing camera display settings

- ▶ In the smart Media-System, select **Vehicle** > **Settings** > **Rear camera** > **Image settings**.
- ▶ Adjust the values for **Brightness**, **Saturation** and **Contrast**.
- ▶ Confirm the display settings with **Done**.

Locking the vehicle

WARNING

If children are left unsupervised in the vehicle, they could:

- open doors, thereby endangering other persons or road users
- get out and be struck by oncoming traffic
- operate vehicle equipment and become trapped, for example

In addition, the children could also set the vehicle in motion, for example, if they:

- release the parking brake
- shift the automatic transmission out of park position P or shift manual transmission into neutral
- start the engine

There is a risk of an accident and injury.

When leaving the vehicle, always take the key with you and lock the vehicle. Never leave children and animals unattended in the vehicle. Keep the keys out of the reach of children.

- ▶ Press the  button on the key. The turn signals flash twice.

Priming and deactivating the anti-theft alarm system

Useful information

The immobiliser prevents the vehicle from being started without the correct key. It is switched on and off automatically.

The anti-theft alarm system triggers a visual and audible alarm if a door, the tailgate or the service cover is opened.

The alarm is not switched off, even if, for example, you close the open door that has triggered it.

Priming

- ▶ Close the doors.
- ▶ Close the tailgate.
- ▶ Close the service cover.
- ▶ Press the  button on the key. The alarm system is primed after approximately 30 seconds.

Deactivating and switching off the alarm

- ▶ Press the  button on the key.

Overview of the on-board computer

Please note

WARNING

Operating the integrated information systems and communications equipment in the vehicle while driving will distract you from traffic conditions. You could then lose control of the vehicle. There is a risk of an accident.

Only operate these devices if road traffic conditions permit. If you are unsure about the surrounding conditions, pull over to a safe location and make entries only while the vehicle is stationary.

WARNING

If the instrument cluster has failed or malfunctioned, you may not recognise function restrictions relevant to safety. The operating safety of your vehicle may be impaired. There is a risk of an accident.

Drive on carefully. Have the vehicle checked at a qualified specialist workshop immediately.

If the operating safety of your vehicle is impaired, you must park the vehicle safely as soon as possible. Consult a qualified specialist workshop.

Display messages and displays in the instrument cluster are only shown for certain systems. Vehicle owners and drivers are responsible for ensuring that the vehicle is operating safely. A vehicle which is not operating safely can cause an accident.

The display shows the outside temperature on the far right in the header. Drivers must pay special attention to road conditions when temperatures are around freezing point. Changes in the outside temperature are displayed after a short delay.

After opening the door, the on-board computer is activated for approximately 15 minutes. To permanently activate the on-board computer, the ignition must be switched on.

Monochrome display overview

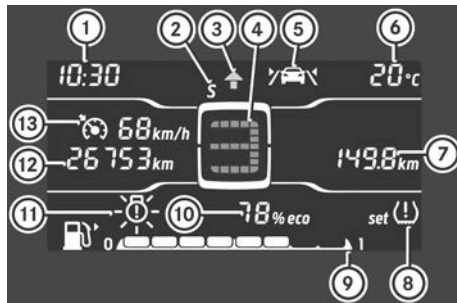

- ① Time
- ② **Vehicles with automatic transmission:**drive program
- ③ **Vehicles with automatic transmission:**gearshift recommendation
- ④ Transmission display
- ⑤ Lane Keeping Assist indicator lamp
- ⑥ Outside temperature display and black ice warning 
- ⑦ Trip meter, current fuel consumption, service display
- ⑧ Tyre pressure monitor
- ⑨ Fuel gauge
- ⑩ eco score display, reserve fuel display
- ⑪ Brake lamp failure warning lamp
- ⑫ Total distance recorder
- ⑬ Cruise control, limiter

When the vehicle is stationary or up to a speed of approximately 5 km/h, the display shows the current fuel consumption as a numerical value in l/h.

Colour display overview

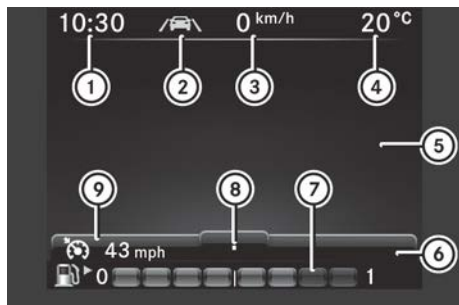



- ① Time
- ② Lane Keeping Assist indicator lamp
- ③ Digital speedometer
- ④ Outside temperature display with black ice warning 
- ⑤ Display field for display messages, menus and lists
- ⑥ Reserve fuel display
- ⑦ Fuel gauge
- ⑧ Transmission display
- ⑨ Cruise control, limiter

Calling up displays

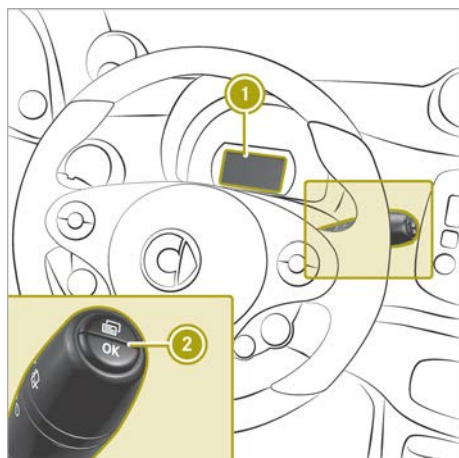
Calling up displays (monochrome display)



- ① Monochrome display
- ② Buttons on the multifunction lever

- ▶ Briefly press the  button on the multifunction lever to scroll forward at menu level.
- ▶ Press and hold the  button on the multifunction lever to directly call up the trip meter.
- ▶ Press and hold **OK** on the multifunction lever to reset the values.





The following displays can be called up one after another:

- Trip meter
- Current fuel consumption
- Service due date
- Setting the time
- Restarts the tyre pressure monitor

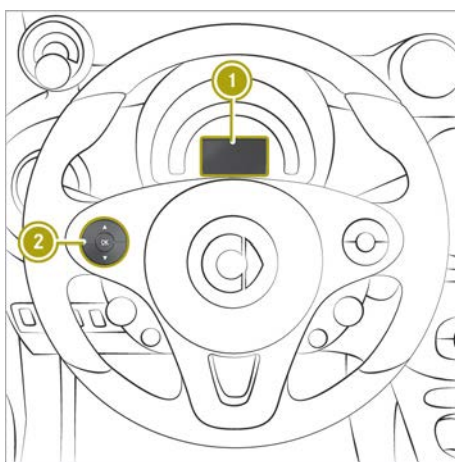
Calling up displays (colour display)

Calling up displays



- ① Colour display
 - ② Left control panel
- ▶ Briefly press  or  on left control panel ②, to scroll forwards or backwards.
 - ▶ Press and hold  or  on left control panel ②, to directly call up the **Distance** display.

The following displays can be called up one after another:

- **Distance**
- Trip computer **from start**

- Trip computer from reset
- eco score from start
- Fuel consumption
- Coolant temperature
- Messages and service
- Settings
- Digital speedometer

Distance display



- ① Trip meter
- ② Total distance recorder

Trip computer display

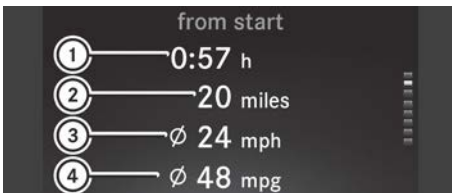

- ① Elapsed time
- ② Distance
- ③ Average speed
- ④ Average fuel consumption

The data in the **from start** menu refers to the start of the journey, whilst the data in the **from reset** menu refers to the last time the submenu was reset.

If the ignition remains switched off for longer than four hours, the **from start** values in the instrument cluster are reset. The eco score display is also reset automatically.

eco score display

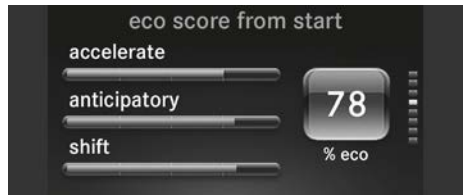

The eco score display provides feedback on how economical the driver's driving behaviour is (▷ page 62).

If the ignition remains switched off for longer than four hours, the eco score display will be automatically reset.

When the eco score display is reset, the **from start** trip computer is also reset.

Fuel consumption display

The display shows the fuel consumption over the previous 15 minutes.

When the vehicle is stationary or up to a speed of approximately 5 km/h, the display shows the current fuel consumption as a numeric value in l/h. If the unit of measurement for distance is set to miles, the display shows two dashes.

Coolant temperature display

The display shows the current coolant temperature. If this rises above 110 °C, then the display shows a display message.

Messages and service display

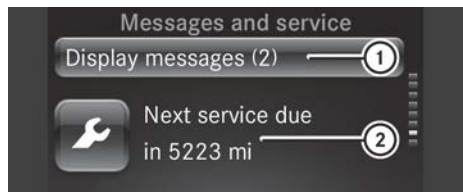

- ① Message memory
- ② Next service due date

The display shows the number of display messages in the message memory and the next service due date.

indicates a minor service. indicates a major service.

To show the display messages, the ignition must be switched on.

- ▶ Press **[OK]** to scroll through the display messages.

Current information on the type of service can be obtained at a smart centre or a qualified specialist workshop.

Digital speedometer display

The display shows the digital speedometer. The digital speedometer in the header is hidden.

England only: the digital speedometer in the header continues to be displayed.

Setting values

Setting values (monochrome display)

Setting the time

- ▶ Press **[Menu]** repeatedly until **[SET]** is shown next to the time.
- ▶ Press **[OK]** until the hour display flashes.
- ▶ Set values.

Resetting values

- ▶ Scroll to the desired display.
- ▶ Press **[OK]** for 3 seconds.

Setting values (colour display)

Setting values



- ▶ Press **[▲]** or **[▼]** to scroll to **Settings**.
- ▶ Press **[▲]** or **[▼]** to scroll to the desired menu.
- ▶ Press **[▲]** or **[▼]** to set the desired data.
- ▶ Press **[OK]** to confirm.

Resetting values

- ▶ Press **[OK]**.
- ▶ Select **yes** and press **[OK]** to confirm.

Setting the time

- ▶ Select **Settings > Time > Set the time**.
- ▶ Set values.
Vehicles with smart Media-System: the time and time format are set in the smart Media-System.

Setting the time format

- ▶ Select **Settings > Time > Time format**.
- ▶ Set the value

Adjusting the instrument cluster lighting

- ▶ Select **Settings > Display > Display brightness**.
- ▶ Set the value

Switching on the ambient lighting

- ▶ Select **Settings > Ambient lighting > On**.

Setting the brightness of the ambient lighting

- ▶ Select **Settings > Ambient lighting > Brightness**.
- ▶ Set the value

Displaying the digital speedometer in the header

- ▶ Select **Settings > Display > Digital speedometer**.
- ▶ Select the **Disp. addit. dig. speedo.** function.
The digital speedometer is displayed in the header.

England only: the digital speedometer in the header cannot be hidden.

Setting the unit for speed in the digital speedometer

- ▶ Select **Settings** > **Display** > **Digital speedometer** > **Unit**.
- ▶ Set the value
The following values are set:
 - Digital speedometer display
 - Digital speedometer in the headerEngland only: only the display unit of the digital speedometer is set.

Setting the unit of measurement for distance

- ▶ Select **Settings** > **Display** > **Units of distance**.
- ▶ Set the value

Setting the temperature unit

- ▶ Select **Settings** > **Display** > **Units of temperature**.
- ▶ Set the value

Starting the tyre pressure monitor

- ▶ Select **Settings** > **Tyre pressure monitor**.

Information on the tyre pressure monitor; see (> page 139).

Setting the language

- ▶ Select **Settings** > **Language (Language)**.
- ▶ Set the value

Operating and setting the smart Audio-System

smart Audio-System overview







WARNING

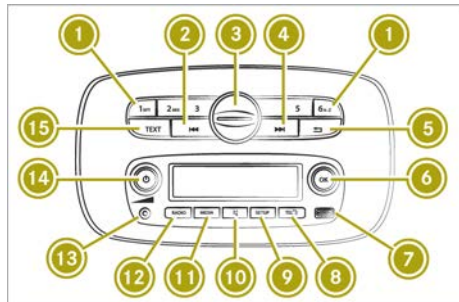

Operating the integrated information systems and communications equipment in the vehicle while driving will distract you from traffic conditions. You could then lose control of the vehicle. There is a risk of an accident.

Only operate these devices if road traffic conditions permit. If you are unsure about the surrounding conditions, pull over to a safe location and make entries only while the vehicle is stationary.



You must observe the legal requirements for the country in which you are currently driving when operating the smart Audio-System.



- ① Number keys **1** - **6**
- ②  Previous station or track
- ③ USB1 port and bracket connection for mobile phone with smart cross connect app
- ④  Next station or track
- ⑤  Goes back one menu level higher
- ⑥ Control for menu selection and station list, **OK** button
- ⑦ USB2 port
- ⑧  Telephone menu, to accept or reject calls
- ⑨  System settings
- ⑩  Mute
- ⑪  Plays back media from external data carriers

- ⑫  Switches on the radio and selects the waveband.
- ⑬ External audio equipment (AUX connection)
- ⑭ Volume control,  button
- ⑮  Sets the radio text

Operating and setting the smart Audio-System

- ▶ To switch on or off: press .
- ▶ To scroll through menus: turn control **⑥**.
- ▶ To select menu options: turn control **⑥** and press the **OK** button.
- ▶ To navigate to the next-highest folders: press the .
- ▶ To set values: turn control **⑥** and press the **OK** button.
- ▶ To increase or decrease the volume: turn control **⑭**.

Using external devices

Useful information

You can connect the following external devices:

- USB devices, iPods® and MP3 players (USB port)
- External audio equipment (AUX connection)
- Bluetooth® devices, such as mobile phones

Removing and fastening the cover of the USB1 port

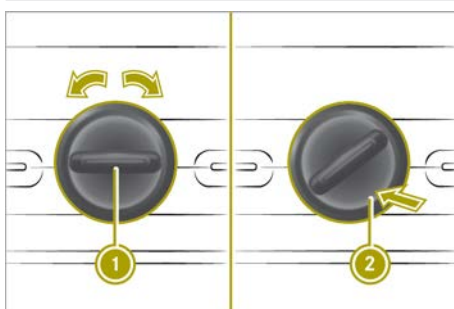

Removing the cover

- ▶ Turn the cover anti-clockwise using handle ①.
- ▶ Press on marking ②.
- ▶ Remove the cover.

Fastening the cover

- ▶ Place cover in position ②.
- ▶ Turn the cover clockwise using handle ①.

Using the smartphone bracket

Useful information

- i** Operating smartphones in the smartphone bracket is permitted exclusively in connection with the smart cross connect App.

The smartphone bracket keeps your mobile phone secured in the vehicle. In order to use the smart cross connect App, rotate the mobile phone to landscape mode.

You can use the USB port behind the smartphone bracket on the left to charge your mobile phone during the journey.

The smartphone bracket is suitable for mobile phones with the following dimensions:

- Thickness: 6 – 10 mm
- Width: 55 – 82 mm
- Length: 120 – 162 mm

Further information is available from any smart Centre.

Fitting the smartphone bracket

- ▶ Remove the cover from the USB1 port.
- ▶ Connect the smartphone bracket to USB1 and turn the locking mechanism clockwise.

Inserting and removing the mobile phone

- ▶ **To insert:** press the right-hand raised button on the bottom edge of the smartphone bracket.
The upper tensioning arm opens.
- ▶ If necessary, press the left-hand button on the bottom edge of the smartphone bracket.
The tensioning arms on the side open.
- ▶ Set the mobile phone in the smartphone bracket.
- ▶ If necessary, press the tensioning arms on the side together to set them to the size of the mobile phone.
- ▶ Press down the upper tensioning arms to secure the mobile phone.
- ▶ **To remove:** press the right-hand raised button on the bottom edge of the smartphone bracket.
The upper tensioning arm opens.
- ▶ Remove the mobile phone from the smartphone bracket.

Operating the smart Audio-System via the mobile phone

You can use the smart cross connect App for iOS and Android to operate the smart Audio-System via a mobile phone.

- ▶ Download the smart cross connect App from the App Store® (iOS) or Google Play™ (Android) and install it on the mobile phone.
- ▶ Connect the mobile phone with the smart Audio-System via Bluetooth®.
- ▶ Insert the mobile phone into the bracket.

Further information about operating the smart Audio-System via mobile phone can be found in the smart cross connect App user's guide.

Adjusting the system settings

Setting the system language

- ▶ Press the **SETUP** button.
- ▶ Select **Language**.
The list of languages appears.
- ▶ Select the language.

Switching the time on or off

- ▶ Press the **SETUP** button.
- ▶ Select **Clock**.
- ▶ Select **ON** or **OFF**.

Setting the time

- ▶ Press the **SETUP** button.
- ▶ Select **Clock**.
- ▶ Select **Set Time**.
- ▶ Set the time.

Setting the time format

- ▶ Press the **SETUP** button.
- ▶ Select **Clock**.
- ▶ Select **Format**.
- ▶ Choose one of the following time formats:
 - **Am/Pm**
 - **24hr**

Adjusting the audio settings

Adjusting the sound

- ▶ Press the **SETUP** button.
- ▶ Select **Audio**.
- ▶ Select **Sound**.
- ▶ Select the desired sound settings:
 - **Bass**: adjusts the bass.
 - **Treble**: adjusts the treble.
 - **Bal.**: adjusts the surround sound (balance) to left or right.

Switching the bass boost on and off

- ▶ Press the **SETUP** button.
- ▶ Select **Audio**.
- ▶ Select **Bass Boost**.
- ▶ Select **ON** or **OFF**.

Resetting audio settings

- ▶ Press the **SETUP** button.
- ▶ Select **Audio**.
- ▶ Select **Audio Default**.
- ▶ Select **Yes**.

Adjusting the volume to the vehicle speed

- ▶ Press the **SETUP** button.
- ▶ Select **Audio**.
- ▶ Select **Speed Vol..**
- ▶ Select the desired level.
The higher the level, the higher the volume will be at increasing road speeds.

Listening to the radio

Switching on the radio

- ▶ Press the **POWER** button.
- ▶ Press the **RADIO** button.

The smart Audio-System receives data transmitted via the Radio Data System (RDS).

Selecting a waveband

- ▶ Press the **RADIO** button repeatedly until the desired waveband appears.

If available, you can switch between the following wavebands:

- FM1
- FM2
- DR1 (digital radio)
- DR2 (digital radio)
- AM

Selecting stations manually

FM and AM waveband

- ▶ Press the **FM/AM** or **FM/AM** button to set the desired frequency.

Digital radio frequency range

- ▶ To select the desired station, press the **FM/AM** or **FM/AM** button.

Holding down the **FM/AM** or **FM/AM** button starts the station search, which stops at the next station with adequate reception.

Setting a station from the station list

- ▶ Press **OK** in radio mode.
The station list appears.
- ▶ Select a station.
- ▶ Press **OK** to confirm.

Updating the station list

- ▶ Press the **RADIO** button until you hear a tone.

Storing a station

- ▶ Select a waveband.
- ▶ Set the station.
- ▶ Press a number key **1** to **6** until you hear a tone.
The station set for this waveband will be saved at the button you have pressed.

Selecting a stored station

- ▶ Select a waveband.
- ▶ Press a number key for the stored station.

Switching traffic announcements on/off

- ▶ Press the **SETUP** button.
- ▶ Select **Radio**.
- ▶ Select **TA**.
- ▶ Select **ON** or **OFF**.

Interrupting a traffic announcement

- ▶ During a traffic announcement, briefly press **←**.

Displaying radio text in FM radio

- ▶ Press the **TEXT** button.
If radio text is available, it will be displayed.

Digital radio (if available)

Information on DAB

- i** Any electronic devices taken into the vehicle may seriously impair radio and DAB radio reception.

Digital radio or DAB (**D**igital **A**udio **B**roadcasting) is a digital transmission standard optimally designed for the mobile reception of radio transmissions. Several programmes are combined into so-called ensembles and transmitted on a single frequency. Some stations only transmit programmes at certain times. If you have selected a programme that has subsequently been removed from the ensemble, it will no longer be received. You will continue to receive the other programmes in the ensemble. Select either a different programme or a different ensemble.

- i** DAB cannot be received everywhere in Europe.

Displaying radio text

This function provides additional data transmitted in the DAB waveband (DR1 and DR2). Besides displaying the artist and track names, information on the current programme may also be available.

- ▶ Press the **TEXT** button.
- ▶ Select **Radio text**.
The **⦿** dot shows that radio text is activated.

Setting alerts

If this function is activated, certain programme categories allow another broadcast to interrupt the current audio playback. Numerous categories can be selected, such as news, business news, sports news etc.

A prerequisite for the reception is that broadcasters process the relevant information. This function is only available in certain countries.

- ▶ Call up the setup menu (▷ page 95).
- ▶ **Radio > DR Interrupt >** Select the desired category.
The **⦿** dot shows the active settings.

- i** Several categories can be selected.
Repeat the procedure if necessary.

Displaying the EPG

EPG (Electronic Program Guide) is available in the DAB waveband (DR1 and DR2).

If the station supports EPG, you can use the EPG (Electronic Programme Guide) to display the current and the following two radio programmes. At the very least, the programme overview contains the name, time and length of each programme.

- ▶ Press the **TEXT** button.
- ▶ Select **EPG**.
- ▶ Select the desired station.

Switching on Intellitext™

If the station supports Intellitext™, you can have additional information displayed, such as news, headlines, business news, sports news etc. A prerequisite for the reception is that broadcasters process the relevant information. Intellitext™ is only available in certain countries.

- ▶ Press the **TEXT** button.
- ▶ Select **Intellitext**.

Using a mobile phone

Connecting a mobile phone

Useful information

The Bluetooth®-capable mobile phone must be compatible with the smart Audio-System. Overview of compatible mobile phones: <http://www.smart.com/connect>.

To make a call, Bluetooth® must be activated on the mobile phone and the smart Audio-System.

Once outside the Bluetooth® reception range, the connection is terminated automatically.

To clearly identify a mobile phone, change the device name (see the manufacturer's operating instructions).

Activating Bluetooth® on a mobile phone

- ▶ Activate Bluetooth® on the mobile phone (see the manufacturer's operating instructions).
- ▶ Search for devices.

Switching on the Bluetooth® function of the smart Audio-System

- ▶ Press the **TEL** button.
- ▶ Turn control **6** to **Bluetooth** and confirm with **OK**.
- ▶ Turn control **6** to **ON** and confirm with **OK**. The **●** dot shows the active setting.

Authorising a mobile phone on the smart Audio-System

- ▶ Press the **TEL** button.
- ▶ Select **Scan devices**.
The system searches for available mobile phones and displays them in a list.
- ▶ Select the mobile phone and confirm with **OK**.
- ▶ Do one of the following:
 - If a code appears in the smart Audio-System display and on the mobile phone, confirm it on the mobile phone.
 - If the code **0000** appears in the smart Audio-System display, enter it and confirm it on the mobile phone.

A maximum of five mobile phones can be authorised. However, only one authorised mobile phone can be connected with Bluetooth® at a time.

Loading and updating the telephone book

- ▶ Press the **TEL** button.
- ▶ Select **Settings > PB download**.
- ▶ If necessary, accept the access confirmation on the mobile phone.

If the mobile phone supports the Bluetooth® PBAP (Phone Book Access Profile) profile, the phone book and call lists will be transferred after you connect.

Removing a mobile phone from the list (de-authorising)

- ▶ Press the **TEL** button.
- ▶ Select **Del. device**.
Authorised mobile phones are displayed.
- ▶ Select the mobile phone to be removed.
- ▶ Select **YES**.

After de-authorisation, the Bluetooth® connection to the mobile phone is no longer established automatically.

Connecting another authorised mobile phone

- ▶ Activating Bluetooth® on a mobile phone
- ▶ Press the **[TEL]** button.
- ▶ Select **Set. device**.
All authorised mobile phones are displayed. The currently connected mobile phone is indicated by a dot.
- ▶ Select the desired mobile phone from the list.

Setting the sound

Adjusting the call volume

- ▶ Press the **[TEL]** button.
- ▶ Select **Settings > Volume > Call**.
- ▶ Select the setting.

Switching the smart Audio-System ringtone on and off

- ▶ Press the **[TEL]** button.
- ▶ Select **Settings > Ringtone**.
- ▶ To switch on: select **Car**.
- ▶ To switch off: select **Phone**.

Adjusting the ringtone volume

- ▶ Press the **[TEL]** button.
- ▶ Select **Settings > Volume > Ring**.
- ▶ Select the setting.

Telephone operation

Calling a contact from the phone book

To call a contact in the telephone book, the mobile phone telephone book first has to be imported into the smart Audio-System.

- ▶ Press the **[TEL]** button.
- ▶ Select **Telephone book**.
- ▶ Select the contact.
The details for the contact are displayed.

- ▶ Select the desired telephone number.
- ▶ Press the **[OK]** button.

Dialling a number

- ▶ Press the **[TEL]** button.
- ▶ Select **Dial Number**.
An input screen appears.
- ▶ Enter the number.
- ▶ Press the **[OK]** button.
- ▶ Select **[☎]**.

Using call lists to call contacts

To call a contact in a call list, the mobile phone telephone book first has to be imported into the smart Audio-System.

- ▶ Press the **[TEL]** button.
- ▶ Select **Call lists**.
- ▶ Select **Dialled, Received** or **Missed**.
- ▶ Select an entry from the list.

Calling the last number dialled

- ▶ Press and hold the **[TEL]** button until the call is established.

Accepting a call

- ▶ Press the **[TEL]** button.

Rejecting a call

- ▶ Press and hold the **[TEL]** button until the call is rejected.

Holding and continuing a call

- ▶ To place a call on hold: select **[⏸]**.
- ▶ To continue the call: press the **[OK]** button.

Transferring a call to the mobile phone

- ▶ Select **[☐]**.
- ▶ To transfer the call back to the smart Audio-System: press **[OK]**.

Entering numbers or characters during a call

- ▶ Select #123.
- ▶ Enter numbers or characters.

Ending a call

- ▶ Press the **OK** button.

Operating external data storage media

Useful information

You can switch between the following media sources, depending on the type of external data carrier connected:

- USB 1 or iPod 1
- USB 2 or iPod 2
- AUX (external audio equipment)
- BT Audio (with Bluetooth® connected device, such as a mobile phone)

Selecting external data carriers

- ▶ Press the **MEDIA** button repeatedly until the desired media source appears in the display.

Operating a USB device or iPod®

Connecting a device

- ▶ Connect the device to the USB port. The device is activated automatically and the first track is played.

Selecting a track

- ▶ In USB mode, press the **OK** button. Available tracks or folders are displayed.
- ▶ Turn control **6**.
- ▶ Press **OK** to confirm.

Rapid search

- ▶ Press the **OK** button. An entry field appears.
- ▶ To enter characters, turn control **6** and press the **OK** button.

Skipping to the next or previous track

- ▶ Press the **▶▶** or **◀◀** button briefly to skip to the next track or press longer for rapid scrolling.

Switching random track sequence on/off

- ▶ Press the **◀◀** button.

Switching the repeat function on/off

- ▶ Press the number key.

Selecting a track from a category with an iPod® connected

- ▶ Press the **OK** button.
- ▶ Select the category from a list. Different categories, such as playlists, artists or albums, can be selected, depending on the connected device.

Displaying metadata

- ▶ Press the **TEXT** button repeatedly until the desired metadata is displayed.

Operating external audio equipment (AUX)

Connecting a device

- ▶ Connect the device to the AUX jack. Use the **MEDIA** button to access the media on a connected AUX device.

Adjusting the volume of external audio equipment

- ▶ Press the **SETUP** button.
- ▶ Select **Audio**.

- ▶ Select **AUX In**.
- ▶ Select one of the following options for the volume:
 - **Low**
 - **Medium**
 - **High**

Bluetooth® device operation

Connecting a device

- ▶ Connect a Bluetooth® audio device the same way you connect a mobile phone with Bluetooth®.

Skipping to the next or previous track

- ▶ Press the **▶▶** or **◀◀** button briefly to skip to the next track or press longer for rapid scrolling.

Displaying metadata

- ▶ Press the **TEXT** button repeatedly until the desired metadata is displayed.

Operating and setting up the smart Media-System





Operating the smart Media-System

Please note

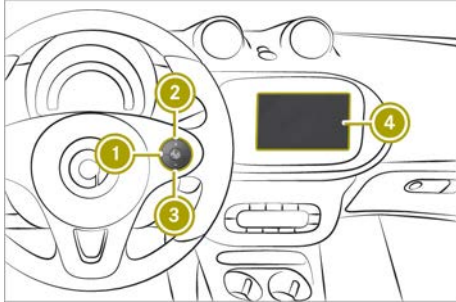
Some functions are restricted while driving.

Controls



- ①  Switches voice control system on and off, accepts and ends a phone call
- ②  Increases the volume
- ③  Reduces the volume
- ④  smart Media-System display

Voice control system

The voice control system can be used to carry out the following smart Media-System functions:

- Enter a destination for navigation.
- Make a call.
- Start an application.

Controls on the smart Media-System

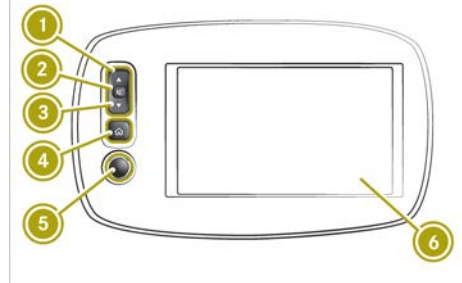

- ① Previous station or track and fast rewind
- ② Mute
- ③ Next station or track and fast forward
- ④ Switches to the home screen
- ⑤ On/off button and volume control 
- ⑥ Touchscreen

Ports on the centre console

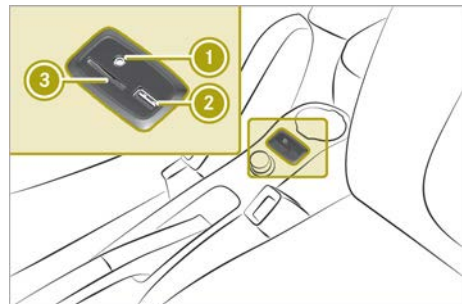

- ① Port for external audio equipment (AUX)
- ② USB port
- ③ SD card slot

Overview of home screen



- ① Radio station, media track
- ② Status of the mobile phone and field strength of the mobile phone network
- ③ Outside temperature
- ④ Time
- ⑤ Traffic reports for the planned route
- ⑥ Map
- ⑦ Next navigation manoeuvre
- ⑧ Context menu
- ⑨ Favourites menu
- ⑩ Main menu
- ⑪ eco score

Switching the smart Media-System on and off

To switch on automatically

- ▶ Start the engine.

To switch off automatically

- ▶ Switch off the ignition and open the door.

To switch on and off manually

- ▶ Press the  button.

Scrolling through a menu or list on the touchscreen

- ▶ Touch the touchscreen with your finger.
- ▶ Swipe up, down, left or right. The selection on the display will then move in the respective direction.

Selecting items on the touchscreen

- ▶ Tap on a menu, an option or an application with one finger. The menu, the option or the application is launched.

Controlling media playback on the touchscreen

- ▶ Swipe to the left. The next media item is played or displayed, e.g. the next track or station.
- ▶ Swipe to the right. Playback is restarted or the previous media item is played or displayed, e.g. the previous track.

Media playback can be controlled in the following playback modes:

- Radio mode
- Music and audio playback
- Image playback
- Video playback

Calling up menus

- ▶ Select **Menu** on the home screen. Select one of the following submenus:
 - **Multimedia**
Radio and media functions
 - **Navigation**
Navigation system
 - **Telephone**
Mobile phone functions
 - **Vehicle**
Reversing camera, eco score and additional functions
 - **Services**
Apps and TomTom services
 - **System**
General systems settings

Confirming settings

- ▶ Select **Done**. Settings are accepted.

Switching off the display

- ▶ Select home page >  > Switch off display.

Adjusting the system settings

Adjusting the display

To set the daytime brightness

- ▶ Select System > Display.
- ▶ Move the Daytime brightness control to the left or right.

To set the nighttime brightness

- ▶ Select System > Display.
- ▶ Move the Nighttime brightness control to the left or right.

To activate automatic switching between daytime and nighttime brightness

- ▶ Select System > Display > Automatic day/night mode.

Displaying night mode constantly

- ▶ Select Force night mode.

Setting the system language

- ▶ Select System > Language.
A list of available languages is displayed.
- ▶ Select the desired language.

i The language of the spoken navigation commands can be selected independently of the system language.

Changing the on-screen keyboard

- ▶ Select System > Keyboards.
- ▶ Select one of the following keyboard layouts:
 - Latin
 - Greek
 - Cyrillic

For the Latin keyboard layout, it is possible to choose between the ABCD, QWERTY, AZERTY and QWERTZ layouts.

Selecting the home screen display

- ▶ Select System > Home page.
A selection of home screen displays appears.
- ▶ Select the desired display.

Resetting to factory settings

- ▶ Select System > Factory settings.
- ▶ Confirm with Yes.
All settings changed in the system will then return to the default values and all destinations, routes and favourites will be deleted.

Setting the time manually

- ▶ Select System > Clock > Set time.
- ▶ Change the minutes and hours of the time shown.

Activating automatic time adjustment

- ▶ Select System > Clock > Set time > Automatic time adjustment.

Setting the time format

- ▶ Select System > Clock > Time format.
- ▶ Choose one of the following time formats:
 - 18:00
 - 6:00 PM
 - 6:00

Displaying status and information

- ▶ Select System > Status & Information.
- ▶ Select one of the following information options:
 - Version information
Software and hardware of the Media-System
 - GPS status
Current GPS signal strength
 - Network status
Signal strength of the data connection
 - Licences
For free and open-source software used
 - Copyright

For text in the TomTom software used.

Adjusting the audio settings

Setting the volume

- ▶ Select **System > Sound > Volumes**.
- ▶ Select one of the following volume settings:
 - **Main volume**
For the whole system
 - **Hands-free**
For the hands-free system
 - **Ringtone**
 - **Navigation**
Volume for the whole navigation system
 - **Computer voice**
Volume of the computer-generated voice
 - **App events**
Volume of events triggered by apps
- ▶ Set the desired volume.

Adjusting the volume to the vehicle speed

- ▶ Select **System > Sound > Speed dependency**.
- ▶ Move the **Speed dependency** control to the left or right.
The higher the value, the more the volume increases with the speed of the vehicle.

Adjusting surround sound (balance)

- ▶ Select **Multimedia > Settings > Sound > Balance**.
- ▶ Select **Manual**.
- ▶ Move the control to the desired position.
- ▶ Confirm with **Done**.

Adjusting the bass and treble

- ▶ Select **Multimedia > Settings > Sound > Bass/Treble > Manual**.
- ▶ Use the control to adjust the bass and treble separately.

Setting a neutral sound for the bass and treble

- ▶ Select **Multimedia > Settings > Sound > Bass/Treble > Neutral**.
Audio is played without increasing the bass or treble.

Activating and deactivating arkamys® bass boost (vehicles without JBL sound system)

- The arkamys® bass boost setting emphasises the bass during playback.
- ▶ Select **Multimedia > Settings > arkamys bass boost**.

Setting the volume for warning tones

- ▶ Select **System > Sound > Warnings**.
- ▶ Move the control to the left or right.

Enabling warning tones when the display is switched off

- ▶ Select **System > Sound > Warnings > Sound warning tones when display turned off**.

Creating and deleting favourites

Creating favourites



- ① Preset
- ② Navigation
- ③ Radio
- ④ Telephone
- ⑤ Services
- ⑥ Context menu

Frequently used settings such as phone contacts and radio stations can be stored as favourites. Six favourites can be stored for each of the following categories:

- Navigation
- Radio
- Telephone
- Services
- ▶ Select **Favourites** on the home screen.
- ▶ Select category.
- ▶ Select the next empty memory position. A list of possible favourites appears.
- ▶ Select Favourites.

Deleting favourites

- ▶ Select **Favourites** on the home screen.
- ▶ Press **[+]**.
- ▶ Select **Remove a favourite**.
- ▶ Perform one of the following steps:
 - Select the favourite to be removed and press **Delete** to confirm.
 - To delete all favourites, select **Remove all favourites**.

Listening to the radio

Switching on the radio

- ▶ Select **Multimedia > Radio**.

Display modes

Useful information

In radio mode there are three different display modes, in which various settings can be made:

- "List" display mode (FM and digital radio)
- "Frequency" display mode (AM and FM radio)
- "Presets" display mode

"List" display mode (FM and digital radio)



- ① Selects the waveband (AM/FM/DAB radio) and preset group (FM/DAB)
- ② Selects previous station
- ③ Selects next station
- ④ Context menu
- ⑤ Selects "Frequency" display mode
- ⑥ "List" display mode
- ⑦ Selects "presets" display mode
- ⑧ Station currently playing

"Frequency" display mode (AM and FM radio)



- ① Selects the waveband (AM/FM radio) and preset group (FM)
- ② Increases or decreases the frequency in small increments
- ③ Station search, forwards or backwards
- ④ Context menu
- ⑤ Adjusts the frequency manually
- ⑥ Station currently playing

“Presets” display mode



- ① Selects the waveband (AM/FM/DAB radio) and preset group (FM/DAB)
- ② Stored station
- ③ Context menu
- ④ Station currently playing

Selecting a station

“List” display mode

- ▶ Swipe up or down in the station list
- ▶ Tap on the desired station.

“Frequency” display mode (AM and FM radio)

- ▶ Slide control on the waveband left or right

Starting a station search

- ▶ Select or in the “frequency” display mode

Storing a station

- ▶ Set the station.
- ▶ Select > **Save as preset**.

Up to six stations can be stored for each waveband.

Displaying radio text

Radio text contains information such as current track or latest news.

- ▶ Select > **Display radio text**.

Displaying digital radio services

- ▶ Select > **Digital radio services**.
- ▶ Select one of the following digital radio services:
 - **EPG** (Electronic Programme Guide)
Programme schedule for the station currently playing
 - **Intellitext**
Programme information and programme schedule for the station currently playing
 - **Slide show**
Displays images to accompany the current broadcast

Other radio settings

Searching for alternative frequencies with the best possible reception quality

- ▶ Select **Multimedia** > **Settings** > **Radio** > **AF** (Alternative frequency).

Receiving traffic reports (i-Traffic)

- ▶ Select **Multimedia** > **Settings** > **Radio** > **i-Traffic** (Traffic program).

Displaying the programme type (e.g. classical)

- ▶ Select **Multimedia** > **Settings** > **Radio** > **PTY** (Program type).

Switching to the corresponding FM station when digital radio reception is poor

- ▶ Select **Multimedia** > **Settings** > **Radio** > **Simulcast**.

Displaying information on certain categories (i-Announcement, digital radio only)

- ▶ Select **Multimedia** > **Settings** > **Radio** > **i-Announcement**.
- ▶ Select category of i-Announcements.

- ▶ Select > **Display radio text**.

Updating the station list

- ▶ Select **Multimedia > Settings > Radio > Update radio list**.

Using a mobile phone

Connecting a mobile phone

Please note

WARNING

If RF transmitters are tampered with or not properly retrofitted, the electromagnetic radiation they emit can interfere with the vehicle electronics. This may jeopardise the operational safety of the vehicle. There is a risk of an accident.

You should have all work on electrical and electronic components carried out at a qualified specialist workshop.

WARNING

If you operate RF transmitters incorrectly in the vehicle, the electromagnetic radiation could interfere with the vehicle electronics, e.g.:

- if the RF transmitter is not connected to an exterior aerial
- the exterior aerial has been fitted incorrectly or is not a low-reflection type

This could jeopardise the operating safety of the vehicle. There is a risk of an accident.

Have the low-reflection exterior aerial fitted at a qualified specialist workshop.

When operating RF transmitters in the vehicle, always connect them to the low-reflection exterior aerial.

Bluetooth® must be enabled both on the mobile phone and on the smart Media-System.

Enabling and disabling Bluetooth®

The mobile phone must be compatible with the smart Media-System.

For an overview of compatible mobile phones, visit: <https://www.smart.com/connect>.

- ▶ Select **Settings > Enable Bluetooth**.
The setting is marked. Bluetooth® is enabled or disabled on the smart Media-System.

Authorising a mobile phone

Authorising a mobile phone for the first time

Bluetooth® must be enabled on the smart Media-System.

- ▶ Select the **Telephone** menu.
- ▶ Confirm the display message with **Yes**.
- ▶ Enter the security code on the mobile phone or accept access confirmation (see Owner's Manual from the manufacturer).
The message **Bluetooth is enabled** is shown.

Authorising another mobile phone

Bluetooth® must be enabled on the smart Media-System.

- ▶ Select **Settings > Manage devices**.
The list of visible mobile phones is displayed.
- ▶ Select a mobile phone from the list.
- ▶ Enter the security code on the mobile phone or accept access confirmation (see Owner's Manual from the manufacturer).
The Bluetooth® connection is established.
The Bluetooth® connection will be established automatically in future.

Downloading telephone data automatically

- ▶ Select **Settings > Download telephone data automatically**.
- ▶ If necessary, accept the access confirmation on the mobile phone.
During connection, up to 1000 contacts are automatically transferred to the smart Media-System.

Connecting another authorised mobile phone

- ▶ Select **Settings** > **Manage devices**.
- ▶ Select a mobile phone.
The current Bluetooth® connection is terminated. The desired mobile phone is connected to the smart Media-System instead.

Removing a mobile phone from the list

- ▶ Select **Settings** > **Manage devices**.
- ▶ Select  > **Delete device(s)**.
- ▶ Select a mobile phone.
- ▶ Select **Delete**.

Terminating a Bluetooth® connection

- ▶ Select **Settings** > **Manage devices**.
- ▶ Select  > **Disconnect all devices**.
- ▶ Select a mobile phone.

If the mobile phone leaves the Bluetooth® receiver range, the connection is automatically terminated.

Using MirrorLink™

Useful information

MirrorLink® is standard for the connection between the smart Media-System and a mobile phone. With MirrorLink®, the content of the display on your mobile phone can be displayed in the smart Media-System.

MirrorLink™ is available for mobile phones with the "Android" operating system.

Further information: <http://www.smart.com/connect>.



To use MirrorLink™, observe the following requirements:

- the mobile phone must support MirrorLink™ version 1.1 and above
- the mobile phone is switched on
- a MirrorLink™ certified App must be installed on the mobile phone
- the GPS connection must be activated on the mobile phone
- the time is set on the smart Media-System

Setting up a connection





- ▶ Activate MirrorLink™ on your mobile phone (see the manufacturer's operating instructions).
- ▶ Connect a mobile phone with a connecting cable to the USB socket in the centre console.
- ▶ Select **Yes**.
Apps which have been certified for MirrorLink™ will be shown in the smart Media-System display.

Calling up MirrorLink™ Apps

- ▶ Select **Services** > **MirrorLink™**.
- ▶ Select the desired app.
The display switches to full screen mode.
- ▶ **To leave full screen display:** press and hold the  button on the smart Media-System until the lower bar is shown.
- ▶ **To exit the display:** select .

MirrorLink™ audio playback

If your mobile phone supports this function, you can control audio playback via the buttons on the smart Media-System.

- ▶ **To select the previous track:** press the  button.
- ▶ **Rewind:** press and hold the  button.
- ▶ **To select the next track:** press the  button.
- ▶ **Fast forward:** press and hold the  button.
- ▶ **To mute:** press the  button.

Disconnecting the MirrorLink™ connection

- ▶ Select  > **Disconnect**.

Telephone operation

Useful information

The following conditions must be fulfilled in order to make a 999 or 112 emergency call:

- a valid and operational SIM card is inserted in the mobile phone
- a mobile phone network is available

Calling a contact from the phone book

- ▶ Select **Telephone book**.
- ▶ Select the contact.
- ▶ Select the contact's telephone number.

If the phone book contains multiple contacts, they can be called up using a **Search**.

Dialling a number

- ▶ Select **Dial number**.
- ▶ Enter a number on the keypad.
- ▶ Select **Call**.

Calling a contact from the call log

- ▶ Select **Call logs**.
- ▶ Select an entry from the list.

The call log can be sorted according to calls made, calls received and missed calls using the corresponding receiver icon.

Accepting and rejecting an incoming call

If a call is incoming, the following information will appear on the display:

- name of caller, if already in the phone book
- number of caller, if name of caller not already in the phone book
- **Private number**, if the caller has Hide caller ID switched on
- ▶ To accept the call, select **Accept**.
- ▶ To reject the call, select **Reject**.
The call will be forwarded to voicemail.

Holding and continuing a call

- ▶ Select **[+]** > **Put on hold**.
- ▶ To continue the call, select **Continue**.

Transferring a call to the mobile phone

- ▶ Select **[+]** > **Mobile phone**.

Ending a call

- ▶ Select **End call**.

Further settings

Setting the volume

- ▶ Select **Settings** > **Volumes**.
- ▶ Set the volume of the hands-free system and the ringtone.

Activating voicemail

- ▶ Select **Voicemail**.
- ▶ Enter the voicemail number on the keypad.
- ▶ Select **Done**.
Voicemail is activated and the voicemail number is dialled.

Configuring voicemail

- ▶ Select **Settings** > **Voicemail configuration**.

Updating the phone book

A Bluetooth® connection must be present.

- ▶ Select **Phone book** > **[+]** > **Update telephone data**.

Updating the call log

- ▶ Select **Call logs** > **[+]** > **Update telephone data**.

Adding a contact to favourites

- ▶ Select **Telephone** > **Phone book**.
- ▶ Select a contact from the list.
- ▶ Select **[+]** > **Add to favourites**.
- ▶ Dial a phone number.

Connecting and operating external data storage media

Useful information

The following external data storage media can be connected:

- USB memory stick (USB 2.0 or 3.0 with max. 64 GB) or iPod™
- SD or SDHC card (max. 64 GB)
- External audio equipment (AUX connection)
- Bluetooth® devices such as mobile phones

The following formats are supported:

- MP3 files
- WMA files
- ACC formats (.AAC, .M4A, .M4B, .M4P, .M4V, .M4R, .MP4 and .3GP)
- OGG Vorbis (.OGG, .OGA)
- PCM 16 bit (.WAV, .PCM)

A data storage medium may contain no more than eight directory levels.

The smart Media-System only recognises the first partition of a data storage medium. The partition must be formatted as FAT or FAT32.

Connecting external data storage media

Connecting a USB memory stick

- ▶ Insert a USB memory stick in the port on the centre console.
Playback starts automatically.

Connecting an SD card

- ▶ Insert an SD card into the SD card slot in the centre console.
Playback starts automatically.

Connecting a Bluetooth® device

- ▶ Authorise and connect a Bluetooth® device, such as a Bluetooth®-capable mobile phone.

Operating external data storage media

Selecting connected external data storage media

- ▶ Select **Menu** > **Multimedia** > **Media**.
- ▶ Select connected medium.

Controlling playback from a USB memory stick or SD card

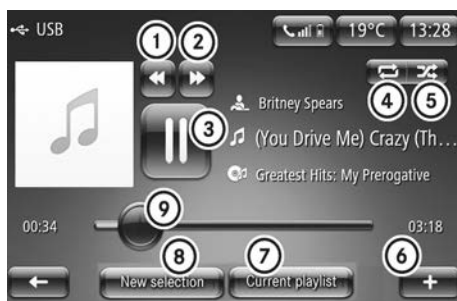

- ① Selects the previous track
- ② Selects the next track
- ③ Stops and continues playback
- ④ Switches track repeat on
- ⑤ Switches random playback on
- ⑥ Calls up the context menu
- ⑦ Displays the playlist
- ⑧ Selects a new track based on categories, e.g. album, genre, folder
- ⑨ Resumes playback at any point in the track

Controlling playback from a Bluetooth® device



- ① Selects a new track
- ② Selects the previous track

- ③ Stops playback
- ④ Selects the next track
- ⑤ Displays the playlist
- ⑥ Calls up the context menu



Selecting a different device

- ▶ Select  > **Change source**.

Connecting another authorised Bluetooth® device

- ▶ Select  > **Find new device**.

Enabling and disabling random playback

- ▶ To enable: select  > **Enable random playback**.
- ▶ To disable: select  > **Disable random playback**.

Displaying details of tracks on a USB memory stick or SD card

- ▶ Select  > **Track details**.

Selecting a track from current playlist

- ▶ Select **New selection** > **Folders**.
The current playlist is displayed.
- ▶ Select **Find**.
A keyboard is shown.
- ▶ Enter the name or part of the name of the track you are looking for.

Selecting a track from categories

- ▶ Select **New selection**.
- ▶ Select category for playback.

Switching album cover display on and off

The album cover must be saved in the audio file.

- ▶ Select **Multimedia** > **Settings** > **Media** > **Display album cover**.

Viewing images

Useful information

Images that have been saved to an SD card or USB memory stick can be viewed in the smart Media-System.

The following file formats can be displayed:

- .JPG
- .GIF
- .PNG
- .BMP

Image playback

Starting image playback

- ▶ Insert SD card or USB memory stick into the corresponding port.
- ▶ Select **Multimedia** > **Images**.
- ▶ Select media source **USB** or **SD**.
- ▶ Select folder.
- ▶ Select image.

Switching between images

- ▶ Swipe left or right.

Specifying a new selection of images

- ▶ Select **New selection**.

Setting image playback

Switching from normal to thumbnail view

- ▶ Select **Thumbnails**.

Switching from thumbnail to normal view

- ▶ Select an image.

Displaying in full screen mode

- ▶ Select  > **Full screen**.

Activating the controls in full screen mode

- ▶ Tap the touchscreen.

Switching from full screen mode to normal view

- ▶ Select  > **Normal view**.

Enlarging the image

- ▶ Select  > **Enlarge**.

Showing images as a slide show

- ▶ Select  > **Slide show**.

Setting the display duration

- ▶ Select  > **Image settings** > **Slide show delay**.
- ▶ Set the desired time using the controls.

Setting default view for image playback

- ▶ Select  > **Image settings** > **Default view**.
- ▶ Select **Normal view** or **Full screen**.

Video playback

Video playback

Starting video playback

- ▶ Insert SD card or connect USB stick.
- ▶ Select **Multimedia** > **Video**.
- ▶ Select **USB** or **SD**.
- ▶ Select folder or video.
All videos in a folder are played one after the other.

-  The size of the video file may have an impact on the performance of the system. Therefore, only play back videos with a length of up to 5 minutes.

Selecting the next or previous video

- ▶ Select  or .

Stopping and continuing playback

- ▶ Select .

Playing a new video

- ▶ Select **New selection**.
- ▶ Select a new video

Setting the video display

Playing videos in full screen mode

- ▶ Select **Full screen**.

Setting the default view for video playback

- ▶ Select  > **video settings**.
- ▶ Select **Normal view** or **Full screen**.

Using the navigation system

Starting the navigation system

Please note

WARNING

Operating the integrated information systems and communications equipment in the vehicle while driving will distract you from traffic conditions. You could then lose control of the vehicle. There is a risk of an accident.

Only operate these devices if road traffic conditions permit. If you are unsure about the surrounding conditions, pull over to a safe location and make entries only while the vehicle is stationary.

The navigation system does not provide information on stop signs, right of way signs, traffic regulations or road safety regulations.

Traffic regulations always take priority over the navigation system's driving recommendations.

Observe the legal stipulations and traffic regulations of the country you are driving in when in navigation mode.

Starting the navigation system

- ▶ Select **Menu > Navigation**.
The following functions can be carried out:
 - searching for a destination
 - planning a route
 - displaying a map
 - calling up TomTom services
 - changing navigation settings

Reading map data

WARNING

SD cards are small parts. They can be swallowed and cause choking. This poses an increased risk of injury or even fatal injury.

Keep the SD card out of the reach of children. If a SD card is swallowed, seek medical attention immediately.

- ! To prevent damage to data, only use the SD card provided for the data in the Media-System or for updating map and systems files.
- ▶ Insert an SD card into the SD card slot in the centre console.
- ▶ Switch on the device.
The map data is read by the navigation system.

Removing an SD card

- ▶ Select **Menu > System > Remove SD card**.
- ▶ Confirm the display message with **Yes**.
- ▶ Press the SD card.
- ▶ Remove the SD card from the slot.

Updating map data

Regular updates will be offered for the map data. The first update can be downloaded for free in the web portal within 90 days of vehi-

cle activation. This requires registration at <http://tomtom.com/forsmart>. Further information is available from any smart Centre.

- ▶ Remove SD card from the vehicle and insert into a computer.
- ▶ Install update software on the computer.
- ▶ Run map update assistant.

i As well as updates, the latest software for the Media-System can be downloaded and Premium Voices by TomTom can be purchased.

Entering and managing destinations

Entering a destination by address

- ▶ When using the navigation system for the first time, enter country.
- ▶ Select **Navigation > Drive to... > Address**.
- ▶ If desired, change the country using the flag symbol.
- ▶ Enter town or postcode.
- ▶ Select the destination from the list.
- ▶ Select the street.
- ▶ Select the house number.
- ▶ Confirm with **Done**.

Searching for a car park near the destination address

This function can be called up when entering the destination.

- ▶ Select  > **Nearby car park**.
A list of car parks near the current destination appears.

Displaying information about the destination address

This function can be called up when entering the destination.

- ▶ Select  > **Show information**

Entering a destination using the map

A location on the map can be selected as the destination.

- ▶ Select **Navigation > Drive to... > Point on map.**
- ▶ Align map view with the destination.
- ▶ Tap the destination point on the display. The symbol selected is highlighted in blue.
- ▶ Tap on the symbol to confirm.

Entering a destination using the voice control system

The voice control system must be switched on.

- ▶ Say the command "Enter address".
- ▶ When prompted by the voice control system, say the destination address, including street name, house number and city.
- ▶ Say the voice command "Yes" or, if several possible destinations are displayed, say the number.

Selecting a destination from the list of last destinations

- ▶ Select **Navigation > Drive to... > Recent destinations.**
- ▶ Select destination.

Entering a destination using geo-coordinates

- ▶ Select **Navigation > Drive to... > Latitude Longitude.**
- ▶ Enter the longitude and latitude

Setting home location

- ▶ Select **Navigation > Settings > Set home address.**
- ▶ Enter a home address

Setting home as a destination

- ▶ Select **Navigation > Drive to... > Home.**

Selecting a saved location as destination

At least one destination must be stored for this function.

- ▶ Select **Navigation > Drive to... > Saved locations.**
- ▶ Select destination.

Managing saved locations

- ▶ Select **Navigation > Settings > Manage saved locations.**

Entering a point of interest

POIs such as museums, restaurants or car parks near a location are displayed on the map.

- ▶ Select **Navigation > Drive to... > Point of interest.**

The following list of surrounding areas appears. A POI can be searched for in these areas:

- **Near my location**
- **Along the route**
- **Near destination**
- **Near home**
- **In a city**

- ▶ Select surrounding area for the search for a POI.

The following list of categories for POIs appears:

- a list of categories for POIs: e.g. a filling station or restaurant
- a POI name search
- a POI search within a category

- ▶ Select category for the search.
- ▶ Select POI.

Managing POIs

Adding a POI category

- ▶ Select **Navigation > Settings > Manage POIs > Add POI category.**
- ▶ Enter the name and symbol for the new POI category.

Deleting a POI category

- ▶ Select **Navigation > Settings > Manage POIs > Delete POI category.**
- ▶ Select the POI category to be deleted.

Adding POIs

- ▶ Select **Navigation > Settings > Manage POIs > Add POI**.
If no POI categories have been defined yet, a prompt appears to enter a POI category.
- ▶ Select the category for the POI.
- ▶ Enter your POI.

Deleting POIs

- ▶ Select **Navigation > Settings > Manage POIs > Delete POI**.
- ▶ Select POI category.
- ▶ Select the POI to be deleted.

Editing POIs

- ▶ Select **Navigation > Settings > Manage POIs > Edit POI**.
- ▶ Select POI category.
- ▶ Customise the POI properties.

Setting alerts for a nearby POI

- ▶ Select **Navigation > Settings > Manage POIs > Warning when near POI**.
- ▶ Select POI category.
- ▶ Set the distance at which the message should appear.
- ▶ Set the type of alert issued.

Entering a destination via “TomTom Places”

POIs from the “TomTom Places” database are available using the “TomTom Places” function.

- ▶ Select **Navigation > Drive to... > TomTom Places**.
A list of search criteria appears which can be used to search for a POI.
- ▶ Select the search criteria.
- ▶ Enter a search term.

Changing the route

Useful information

Once the destination has been selected, the navigation system calculates the route to the destination. The following options are available for adjusting the route guidance:

- calculate alternative routes
- adjust routes calculated by the navigation system
- plan routes in advance and travel via specific way points
- adjust settings for calculating routes

Once the route is calculated, a route summary is shown. By default, the quickest route will be calculated for route planning, taking into account IQ Routes™. Traffic information is taken into account when calculating the route.

The “route overview” function allows you to set whether the summary of a calculated route is automatically faded out from the display after 10 seconds.

If the route is not confirmed with **Done**, route guidance will start automatically after approximately ten seconds.

Displaying a planned route

Calculating the route

- ▶ Enter a destination.
- ▶ Select **Done**.

Displaying the route details

- ▶ Select **[+] > Route details**.
- ▶ Select one of the following functions:
 - **Display instructions**
An overview of the route with directions appears.
 - **Display a map of the route**
The route appears on a map.
 - **Start demonstration**
A simulation of the route guidance for the planned route is started. To end the simulation, tap on the touchscreen and confirm you want to cancel by tapping on **Yes**.
 - **Display the destination**
The destination for the route appears.

By pressing , it is possible to search for a car park near the destination or add the location to the saved locations.

- ▶ **Show traffic on route**

Traffic disruptions along the route are shown.

- ▶ **Summary**

A summary of the route details appears.

Saving a planned route

- ▶ Select  > **Save Itinerary**.

Changing the route

Cancelling the route

- ▶ Select **Navigation** > **Change route** > **Cancel route**.

Route guidance can be resumed again when a new destination is entered.

Calculating an alternative route

- ▶ Select **Navigation** > **Change route** > **Calculate alternative**.

A new route is calculated and displayed that takes you on different roads.

- ▶ Select the alternative route or a previous one.

Route guidance via way point

The route can be adjusted by entering up to four way points.

- ▶ Select **Navigation** > **Change route** > **Travel via**.

If a way point has already been entered, a list of the saved way points will be displayed.

- ▶ Select **Add**.

- ▶ Select a new way point from **Address**, **Recent destinations**, **Saved locations**, **TomTom Places** or **POI**.

The new way point is added.

Avoiding road blocks

The route can be changed if a section of road along the route is blocked or there is a traffic jam.

- ▶ Select **Navigation** > **Change route** > **Avoid roadblock**.

- ▶ Select the length of the route that needs to be avoided.

Avoiding specific roads

The route is calculated to avoid specific roads.

- ▶ Select **Navigation** > **Change route** > **Avoid part of route**.

A list of the roads on the route is displayed.

- ▶ Select the road you wish to avoid.

Taking traffic disruptions into account

The route is recalculated based on current traffic information

Traffic information is not available in all countries and regions.

- ▶ Select **Navigation** > **Change route** > **Minimise delays**.

An overview of the traffic disruptions along the route will be shown.

- ▶ Select the traffic disruption you wish to avoid.

Planning a route in advance

Adding a route

- ▶ Select **Navigation** > **Routes**.

- ▶ Select **Add**.

- ▶ Select the starting point of the route.

- ▶ Enter the route destination.

- ▶ Enter at least one way point for the route.

- ▶ Enter the route name.

- ▶ Confirm with **Done**.

Starting navigation using a saved route

- ▶ Select **Navigation** > **Routes**.

- ▶ Select the desired route.

- ▶ Select  > **Go**.

Setting route planning

Selecting the route type

- ▶ Select **Navigation** > **Settings** > **Route planning** > **Route types**.

- ▶ Select one of the following settings:

- Ask for every route
- Always plan the fastest route
- Always plan eco routes
- Always avoid motorways
- Always plan the shortest route

Selecting the setting for toll roads

- ▶ Select **Navigation > Settings > Route planning > Toll roads**.
- ▶ Select one of the following settings:
 - Ask for toll roads on route
 - Always avoid toll roads
 - Do not avoid toll roads

Selecting the setting for ferry connections

- ▶ Select **Navigation > Settings > Route planning > Ferry connections**.
- ▶ Select one of the following settings:
 - Ask for ferries on my route
 - Always avoid ferries
 - Do not avoid ferries

Selecting the setting for unpaved roads

- ▶ Select **Navigation > Settings > Route planning > Unpaved roads**.
- ▶ Select one of the following settings:
 - Ask for unpaved roads on my route
 - Always avoid unpaved roads

Selecting the setting for carpool lanes

Carpool lanes are lanes which can only be used by vehicles with at least two occupants.

- ▶ Select **Navigation > Settings > Route planning > Carpool lane settings**.
- ▶ Select one of the following settings:
 - Ask for carpool lanes on my route
 - Always avoid carpool lanes.
 - Never avoid carpool lanes

Using information during route guidance

Useful information

Navigation announcements provide guidance during the journey without distracting you from traffic conditions. In addition, the display shows information about the route.

Switching navigation announcements on and off

- ▶ Select **Navigation > Settings > Turn on voice guidance** or **Turn off voice guidance**.

Information such as traffic reports and warnings will be played even if the navigation announcements have been deactivated.

During route guidance, traffic information can be shown for the route ahead. The following traffic information can be received:

- Traffic announcements (RDS/TMC)
- HD Traffic (a TomTom Live Service, subject to a fee)

Live services are not available in all countries and regions. For more information, visit: <http://tomtom.com/services>.

Tracking navigation on the display



- ① Zoom in and out of the map view
- ② Maximum permitted speed
- ③ Name of the next main road or information about the next street sign
- ④ Traffic information
- ⑤ Route information
- ⑥ Compass and symbol for two or three-dimensional map display
- ⑦ Context menu
- ⑧ Next navigation manoeuvre with distance and symbol for volume adjustment
- ⑨ Information about current radio or audio equipment

- ▶ Tap on the desired symbol in the map view.

The navigation system zooms in on the map view as the vehicle approaches a junction. This makes it possible to follow turning manoeuvres more accurately.

Shortly before navigating a motorway junction or exit, the display will show a three-dimensional representation of the lanes and the exit. Lane Keeping Assist is not available for all junctions in all countries.

Traffic information details

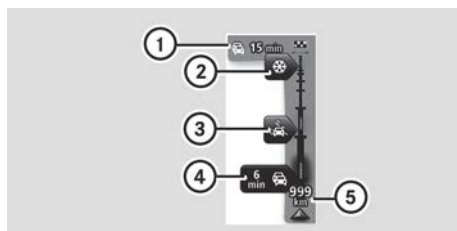

- ① Overall delay on route
- ② Traffic disruption (packed snow)
- ③ Traffic disruption (rain)
- ④ Traffic disruption (traffic jam)
- ⑤ Current location and distance to next traffic disruption

During route guidance, traffic information is shown for the route ahead. When there are a number of traffic disruptions in quick succession, only the very next disruption on the route will be displayed.

Traffic information is not available in all countries and regions.

Colour	Meaning
Grey	Unknown or unexplained situation
Orange	Slow-moving traffic
Red	Traffic jam
Dark red	Standstill or road blocked

Calling up more detailed information about the traffic problems

- ▶ Tap on the display for traffic information during route guidance.

Scrolling through the traffic reports

- ▶ Tap on the message on the touchscreen and swipe left or right.

Displaying the map for a location

Useful information

With the “View map” function, the display shows a two-dimensional map. The map shows your current position, as well as a number of other elements, such as Favourite.

Displaying a map

- ▶ Select **Navigation** > **View map**.
A map of the surrounding area will be shown.
- ▶ To search, select **[+]** > **Search**.

Controlling the map view

Moving the map

- ▶ Tap on the centre of the touchscreen.
- ▶ Swipe in the desired direction. The map will then move in the respective direction.

Zooming in on the map

- ▶ Place two fingers slightly apart in the middle of the touchscreen.
- ▶ Move your fingers away from each other.

Reducing the scale of the map

- ▶ Place two fingers, at a greater distance apart, on the screen.
- ▶ Pull your fingers towards each other.

Showing and hiding additional information on the map

- ▶ Select **Navigation** > **View map**.
- ▶ Select **[+]** > **Change map information**.
- ▶ Select one of the following information options:
 - Traffic information
 - Names
 - Points of interest (POIs)
 - Satellite images
 - Coordinates

Using TomTom Services with the navigation system

Useful information

The **TomTom Services** menu can be used to call up and manage traffic information and other TomTom Live Services.

TomTom Live Services are available for a subscription fee. The following TomTom Services come pre-installed and, following activation, can be used free of charge for a period of three years:

- HD Traffic
- Radar cameras (not available in all countries)
- Weather
- TomTom Places

More information on services <http://www.tomtom.com/services>.

More information on availability in specific countries: <http://smart.com/connect>

TomTom Services can also be called up and managed in the **Services** menu. In the main menu, select **Services > TomTom Services**.

- i** If you have subscribed to the "TomTom Traffic" service, the "Traffic info" menu will be called "TomTom Traffic".

Activating TomTom Services

TomTom Services must be activated before using them for the first time. If TomTom Services are not yet activated, a corresponding button will be displayed in the main menu and in the **Services** menu.

- ▶ Select **Services > TomTom Services**. The TomTom Services installed on the device are displayed.
- ▶ Select the desired TomTom Service. **Update installed** is shown. TomTom Services are activated.

Starting TomTom Services

- ▶ Select **Navigation > TomTom Services**. The **TomTom Services** menu is displayed.

Checking subscription status for TomTom Services

- ▶ Select **Navigation > TomTom Services > My Services**.

The services available on the device and their subscription status will be shown.

Displaying traffic information along the route

- ▶ Select **Navigation > TomTom Services > Traffic > Display traffic info. on route**.
- ▶ To switch between traffic information items, tap on the message on the touchscreen and swipe left or right.









Adjusting the route according to traffic disruptions





- ▶ Select **Navigation > TomTom Services > Traffic > Minimise delays**.

Viewing traffic disruptions on the map

- ▶ Select **Navigation > TomTom Services > Traffic > View map**. Traffic disruptions are displayed on the map as symbols.
- ▶ To view detailed information, tap on a traffic disruption symbol.

The following symbols are used:

Sym-bol	Meaning
	Traffic jam
	Road blocked
	Traffic disruption
	Construction site
	One or more lanes blocked
	Accident
	Traffic disruption avoided using the traffic information
	Fog

Sym- bol	Meaning
	Wind
	Snow
	Black ice
	Rain

Viewing traffic information for the route to work

- ▶ Select **Navigation** > **TomTom Services** > **Traffic** > **Traffic info. for route to work**.
- ▶ Select one of the following settings:
 - **Home to work**
 - **Work to home**
 - **Change the home to work route**

Changing the settings for traffic information

- ▶ Select **Navigation** > **TomTom Services** > **Traffic** > **Traffic info. settings**.
- ▶ Select one of the following settings:
 - **Always change to this route**
The navigation system automatically changes the route if a faster route has been calculated due to a traffic report along the route.
 - **Request confirmation for route**
If a faster route has been calculated due to a traffic report, the navigation system will ask which route should be used.
 - **Never change my route**
The navigation system will not change the route, even if a traffic announcement has been made.

Reading aloud traffic information

- ▶ Select **Navigation** > **TomTom Services** > **Traffic** > **Read traffic info. aloud**.

Setting the navigation system

Setting the voice

The voice which is used for navigation commands can be changed. It is possible to choose between computer-generated voices or voices recorded by professionals. For voices that have been recorded by professionals, only basic navigation commands will be spoken.

- ▶ Select **System** > **Sound** > **Voice**.
- ▶ Select voice for playback.
- ▶ To listen to the voice, select **Test**.



Setting the voice output

- ▶ Select **System** > **Sound** > **Voice output settings**.
- ▶ Select one of the following settings:
 - **Read early warning instructions aloud**
 - **Read motorway lane instructions aloud**
 - **Read traffic info. aloud when navigating**
 - **Read foreign street names aloud**
 - **Read street numbers aloud**
 - **Read street names aloud**
 - **Read weather information aloud**
 - **Read POI warnings aloud**
 - **Read aloud warnings**
 - **Read signposts aloud**

Changing the map

- ▶ Select **Navigation** > **Settings** > **Change map**.
- ▶ Select the desired map.

Changing the map colours

- ▶ Select **Navigation** > **Settings** > **Change map colours**.
- ▶ Press  or  to select the desired display.

Setting safety warnings

- ▶ Select **System > Safety warnings**.
- ▶ To select the desired settings:
 - **Suggest driving breaks**
 - **Warn when driving near schools**
 - **Warn when driving faster than allowed**
 - **Warn when driving faster than a set speed**
- ▶ Select **Resume**.
- ▶ Select a warning tone for the respective safety warning.

For the “Warn when driving faster than a set speed” function, the speed above which the warning tone should sound must be entered.

Setting the units of measurement for distance

All units of measurement for distance in the navigation system can be changed. The units of measurement for distance of other displays are not changed, such as distance displays for the eco score or the on-board computer.

- ▶ Select **System > Set units > Distance units**.
- ▶ Select one of the following settings:
 - **Kilometres**
 - **Miles**

Setting the units for GPS coordinates

- ▶ Select **System > Set units > GPS coordinate display**.
- ▶ Select one of the following settings:
 - **Degrees (d°)**
 - **Degrees, Minutes (d° m.m')**
 - **Degrees, Minutes, Seconds (d° m\' s \')**

Managing apps

Useful information

If available, apps may be installed and managed on the smart Media-System. Apps and the use of TomTom services can be called up and managed in the **Services** menu.

The smart Media-System uses a mobile phone connection for data connection. Please take note of the following information when using data services:

- The mobile connectivity and built-in SIM card for this vehicle can only be used for data services offered by certain third parties, as well as Daimler AG, via the Smart Media-System for use in the vehicle. The use of data services requires the conclusion of separate agreements between the vehicle user and the respective provider. Voice service usage is not permitted. As such, the SIM card must be permanently installed as factory equipment.
- The mobile communications connectivity and the SIM card may only be used responsibly in accordance with the applicable laws and other legal requirements of the corresponding countries, insofar as this is within the power of the vehicle user.
- Upgrading, reproduction, reverse assembly and disassembly of the SIM card are not permitted. Statutory authority remains unaffected.

Failure to follow the above instructions, depending on the severity of non-compliance, can in some cases lead to temporary or permanent deactivation of the mobile connection and the SIM card, in particular to protect Daimler AG and its contractual partners from negative legal consequences arising from non-compliance. The availability of mobile connectivity in individual countries depends on the existence of corresponding mobile service agreements with local mobile network providers; availability can therefore change from time to time. The maximum period of validity for the mobile connectivity is 15 years from the time of installation in the vehicle.

Installing Apps

If available, apps may be used on the Smart Media-System. This requires registration at <http://tomtom.com/forSMART>.

- ▶ Remove SD card from the vehicle and insert into a computer.

Further information: <http://tomtom.com/forSMART>.

Displaying and calling up apps

Displaying apps

- ▶ Select **Services** > **Settings** > **Applications manager**.

The Apps installed on the SD card are shown in the smart Media-System.

Calling up apps

- ▶ Select **Services**.
- ▶ Select the desired app.

Calling up the connectivity manager

The connectivity manager allows you to manage the devices connected to the Smart Media-System.

- ▶ Select **Services** > **Settings** > **Connectivity manager**.

Managing data sharing

Enabling or disabling data sharing

If data sharing has not been enabled beforehand, a corresponding message is shown when the smart Media-System is started up. Data sharing can be enabled or disabled at any time.

- ▶ Select **Services** > **Settings** > **Data sharing**.
- ▶ Select one of the following settings:
 - **Yes**
Enable data sharing
 - **No**
Disable data sharing.

Displaying additional information

- ▶ Select **Services** > **Settings** > **Data sharing** > **About**.

Displaying text in another language

- ▶ Select **Services** > **Settings** > **Data sharing** > **Language**.

Stowing small objects

Please note

WARNING

If you stow objects in the vehicle interior in an unsuitable way, they could slip or be thrown around and thus hit vehicle occupants. Additionally, the cup holders, open stowage spaces and mobile phone brackets cannot restrain the objects placed in them in the event of an accident. There is a risk of injury, especially in the event of braking or sudden changes in direction.

- Always stow objects so they cannot be thrown around in these or similar situations.
- Always ensure that objects do not protrude over the top of stowage compartments or stowage nets.
- All closable stowage compartments should be closed before beginning your journey.
- Always stow and secure heavy, hard, pointed, sharp-edged, fragile objects or objects which are too large behind the last bench seat or under the passenger seats.

WARNING

The cup holder cannot secure a drinks container in place during a journey. If you use a cup holder during a journey, the drinks container could be flung around and liquid could be spilt. Vehicle occupants could come into contact with the liquid and, in particular, be scalded by hot liquid. You could be distracted from the traffic situation and lose control of the vehicle. There is a risk of an accident and injury.

Only use the cup holder when the vehicle is stationary. Only place containers of a suitable size in the cup holder. Seal the container, in particular when it contains hot liquid.

 Only use the cup holders for containers of the right size and which have lids. The drinks could otherwise spill.

Using the compartments

- ▶ To stow objects, use the following compartments:
 - Stowage compartments in the doors
 - Glove compartment
 - Spectacles compartment above the driver's seat
 - Stowage net in the front-passenger footwell
 - Drawer in the centre console
 - Velcro strip on the front passenger seat for stowing a handbag
 - Cup holders in the front centre console
 - Cup holder in the rear centre console with a recess for storing a mobile phone
 - **smart fortwo coupé:** stowage compartment in the lower tailgate

Locking/unlocking the glove compartment

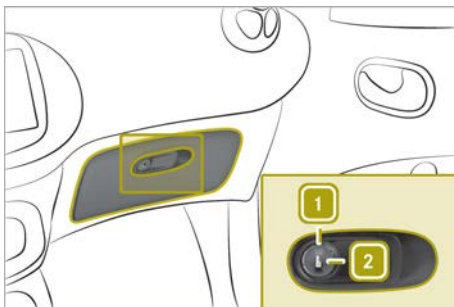

- ▶ Insert the key into the lock and turn clockwise to position **2** (to lock) or anticlockwise to position **1** (to unlock).

Opening the stowage compartment in the tailgate (smart fortwo coupé)

 Do not exceed the lower tailgate maximum load of 100 kg. It may otherwise become damaged.

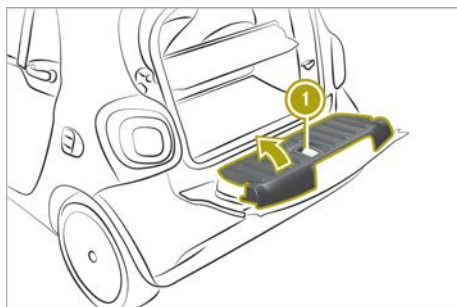

- ▶ Open the tailgate.
- ▶ Pull handle ① on the inside of the lower tailgate upwards.
- ▶ Lift up the cover in the direction of the arrow.

Stowing luggage and large objects

Please note

⚠ WARNING

If you stow objects in the vehicle interior in an unsuitable way, they could slip or be thrown around and thus hit vehicle occupants. Additionally, the cup holders, open stowage spaces and mobile phone brackets cannot restrain the objects placed in them in the event of an accident. There is a risk of injury, especially in the event of braking or sudden changes in direction.

- Always stow objects so they cannot be thrown around in these or similar situations.
- Always ensure that objects do not protrude over the top of stowage compartments or ruffled pockets.
- All closable stowage compartments should be closed before beginning your journey.
- Always stow and secure heavy, hard, pointed, sharp-edged, fragile objects or objects which are too large behind the last bench seat or under the passenger seats.

⚠ WARNING

Combustion engines emit poisonous exhaust gases such as carbon monoxide. If the tailgate is open when the engine is running, particularly if the vehicle is moving, exhaust fumes could enter the passenger compartment. There is a risk of poisoning.

Turn off the engine before opening the tailgate. Never drive with the tailgate open.

The handling characteristics of a laden vehicle are dependent on the distribution of the load within the vehicle.

Observe the following loading guidelines when loading and transporting luggage and loads:

- never exceed the maximum permissible gross vehicle weight or the permissible axle loads for the vehicle (including occupants).
- the load must not protrude above the upper edge of the head restraints.
- ensure that no items of luggage can enter the passenger compartment above or between the seats.
- ensure that loaded objects are stowed safely and are secured.
- load heavy objects at the bottom and light objects at the top.
- the load compartment is the preferred place to stow objects.
- stow heavy loads as far forwards and as low down in the load compartment as possible.

Opening the boot (smart fortwo coupé)

- ⚠ The tailgates swing to the rear, both upwards and downwards, when opened. Therefore, make sure that there is sufficient clearance above, behind and below the tailgates.

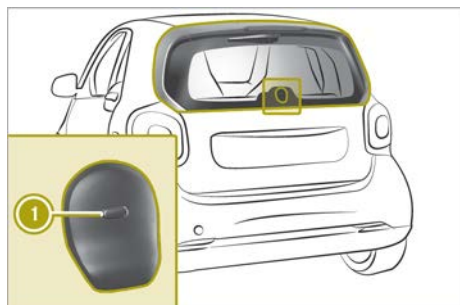

- ▶ Press the  button on the key.
- ▶ Press button ①.
- ▶ Fold the upper tailgate upwards.

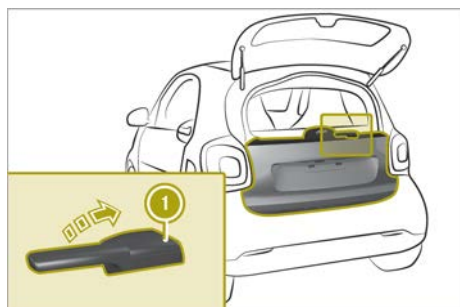

- ▶ Pull lever ① upwards.
- ▶ Fold the lower tailgate down.

Closing the boot (smart fortwo coupé)

- ▶ Fold the lower tailgate upwards and engage on both sides.
- ▶ Pull the upper tailgate down and press it closed.
- ▶ Press the  button on the key. The vehicle is locked.

Opening the boot (smart fortwo cabrio)

Opening the tailgate

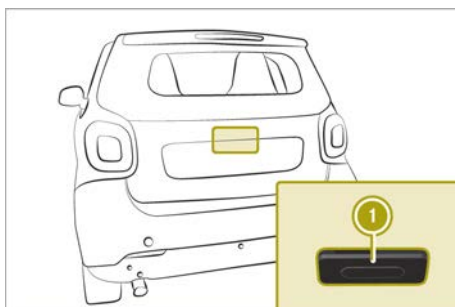

- ▶ Press the  button on the key.
- ▶ Press button ① in the handle recess.
- ▶ Fold down the tailgate.

Opening the rear soft top

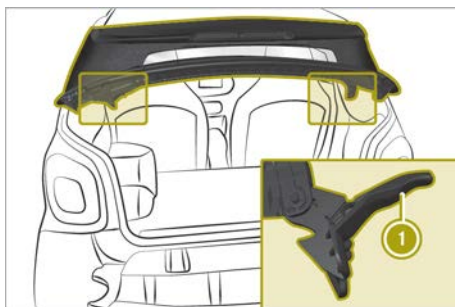

- ▶ Open the tailgate.
- ▶ Press both latch levers ①.
- ▶ Swing the rear soft top up.

Closing the boot (smart fortwo cabrio)

Closing the rear soft top

- ▶ **!** When closing the tailgate, you must first lock the tail cover. Otherwise, you could break the catch lever.
- ▶ Pull the rear soft top down until it engages.
- ▶ Lock the rear soft top with both latch levers.

Closing the tailgate

- ▶ Pull the tailgate up until it engages.
- ▶ Press the  button on the key. The vehicle is locked.

Enlarging the load compartment: folding the front-passenger seat backrest forwards

Folding down the front-passenger seat backrest (using the lever)

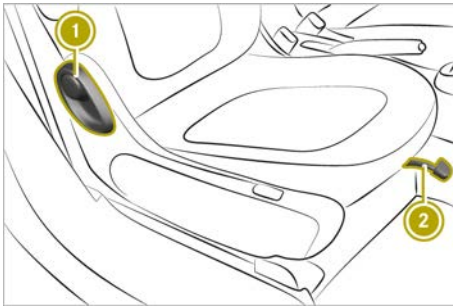

Seat with a lever

- ▶ Lift lever ② and slide the front passenger seat to its rearmost position.
- ▶ Pull lever ① forwards.
- ▶ Fold the seat backrest forwards at the same time.

Folding down the front-passenger seat backrest (using the handwheel)

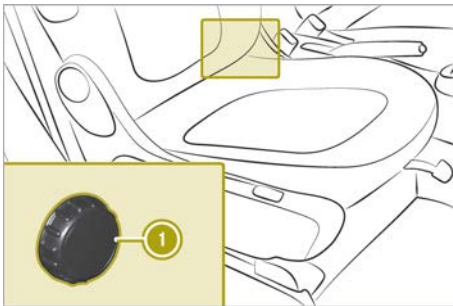

Seat with a handwheel

- ▶ Turn handwheel ① forward.

Folding back the front-passenger seat backrest

Please note

WARNING

If the seat backrest is not engaged, it may fold forwards, e.g. during braking or in the event of an accident.

- As a result, a backrest which is not engaged would press you into the seat belt. The seat belt cannot perform its intended protective function and could additionally cause injury.
- The backrest cannot restrain objects or loads in the boot.

This poses an increased risk of injury.

Before every journey, make sure that the backrest is engaged as described.

Folding back the front-passenger seat backrest (using the lever)

- ▶ Pull lever ①.
- ▶ Push the seat backrest back at the same time until it engages.

Folding back the front-passenger seat backrest (using the handwheel)

- ▶ Turn handwheel ① backwards.

Using the boot separator

Fitting the boot separator

WARNING

On its own, the boot cover cannot secure or restrain heavy objects, items of luggage and heavy loads. You could be hit by an unsecured load during sudden changes in direction, braking or in the event of an accident. There is an increased risk of injury or even fatal injury.

Always store objects so that they cannot be flung around. Secure objects, luggage or loads against slipping or tipping over, e.g.

by using lashing material, even if you are using the boot cover.

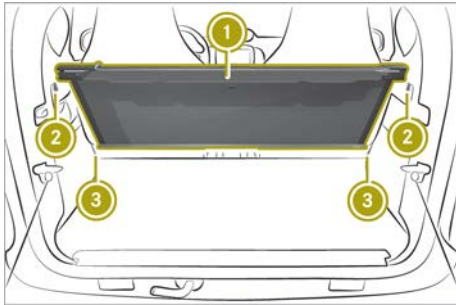

For easier fitting, fold the front-passenger seat backrest forwards.

- ▶ **smart fortwo coupé:** open the upper and lower tailgate.
- ▶ **smart fortwo cabrio:** open the lower tailgate.
- ▶ **smart fortwo cabrio:** fold the rear soft top up.
- ▶ Hold boot separator ① with the luggage net bag in the direction of the passenger compartment in the boot.
- ▶ Insert the boot separator into bracket ② on the right side.

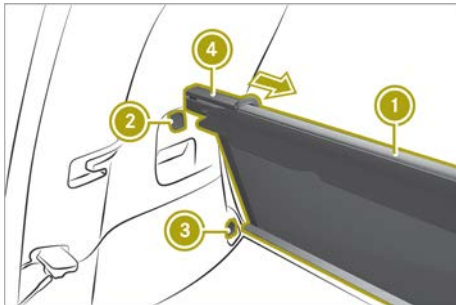

- ▶ Slide handle ④ to the right and hold.
- ▶ Insert the boot separator into bracket ② on the left side.
- ▶ Release handle.
Boot separator ① snaps into place.
- ▶ Secure the luggage net bag with the Velcro fasteners.

If the boot separator is not required and no subwoofer is installed, it can be attached to brackets ③.

Hooking in and unhooking the boot separator

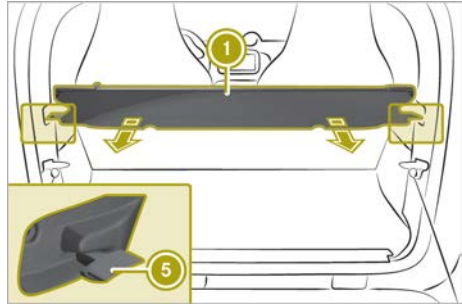

- ▶ Grip boot separator ① in the middle and pull it back.
- ▶ Hook boot separator into left and right rear brackets ⑤.

Useful information

The engine compartment in the smart is located at the rear, below the boot. Here you can check the engine oil level and top up the engine oil.

All other tanks for service fluids are located under the service cover at the front.

When working on the vehicle, always comply with all safety regulations.

Removing/fitting the subwoofer

Removing the subwoofer

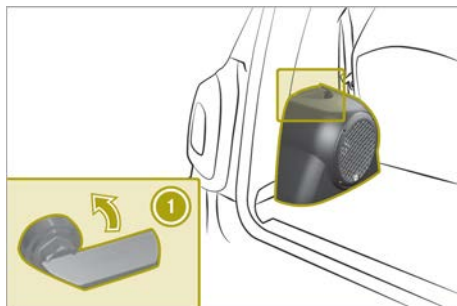

- ▶ Release quick-release fastener ① in the direction of the arrow.
- ▶ Reach into the recess on the quick-release fastener.
- ▶ Detach, tilt and pull the subwoofer to the right.
- ▶ Pull out the connector.

Fitting the subwoofer

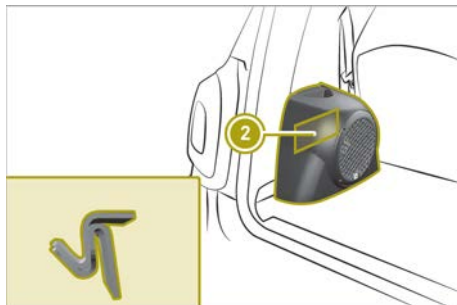

- ▶ Insert the connector.
- ▶ Place the subwoofer at the base of the side trim.
- ▶ Turn quick-release fastener ① upwards.
- ▶ Press the bracket into the recess in side trim ②.
- ▶ Turn quick-release fastener ① to the right.

Opening and closing the engine compartment cover

Please note

⚠ WARNING

The engine compartment cover can become very hot. There is a risk of injury if you remove the engine compartment cover to work in the engine compartment.

Allow the engine to cool down before removing the engine compartment cover.

⚠ WARNING

Combustion engines emit poisonous exhaust gases such as carbon monoxide. If the engine compartment cover has not been fitted correctly when the engine is running, particularly whilst the vehicle is moving, exhaust gases may enter the vehicle interior. There is a danger of poisoning.

Always switch off the engine before removing the engine compartment cover. Make sure that the engine compartment cover has been fitted correctly.

Opening the engine compartment cover

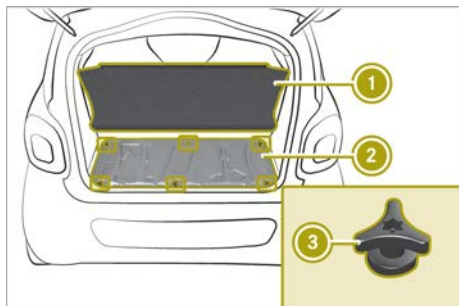

The vehicle must be secured against rolling away.

- ▶ **smart fortwo coupé:** open the upper and lower tailgate.
- ▶ **smart fortwo cabrio:** open the lower tailgate.
- ▶ **smart fortwo cabrio:** fold the rear soft top up.
- ▶ **Vehicles with a subwoofer:** remove the subwoofer.
- ▶ **Vehicles with a boot separator:** attach the hook to the upper bracket of boot separator ①.
- ▶ Fold up the carpet.
- ▶ Unscrew and remove screws ③ in the engine cover.
- ▶ Remove engine cover ②.

Closing the engine compartment cover

- ▶ Slide engine compartment cover ② forwards to the stop.
- ▶ Tighten screws ③.
- ▶ Fold down the carpet and push it under the side panelling.
- ▶ **Vehicles with a subwoofer:** fit the subwoofer.
- ▶ **Vehicles with a boot separator:** detach the hook on the boot separator.

Opening and closing the service cover

Please note

⚠ WARNING

If the service cover is not locked, it may come loose during driving and block your view or endanger other road users. There is a risk of an accident and injury.

Therefore, make sure that the service cover is locked before driving off.

⚠ WARNING

If the windscreen wipers start to move when the service cover is open, you could become caught up in the wiper rods. There is a risk of injury.

Always switch off the windscreen wipers and the ignition before you open the service cover.

- ▶ To ensure unhindered air intake, completely remove any dirt or snow from the ventilation slots above the service cover.

The vehicle must be secured against rolling away.

On vehicles with a lockable service cover, the service cover must be unlocked before it is opened.

Unlocking the service cover on vehicles with a lockable service cover

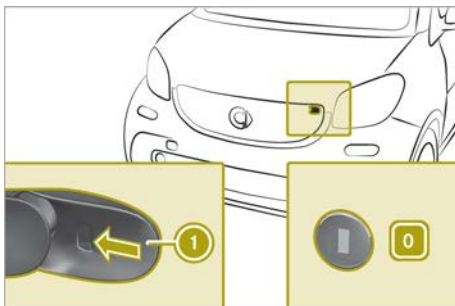

- ▶ Remove lock cover ① on driver's side.
- ▶ Insert the key into the lock and turn it to position 0.

Opening the service cover

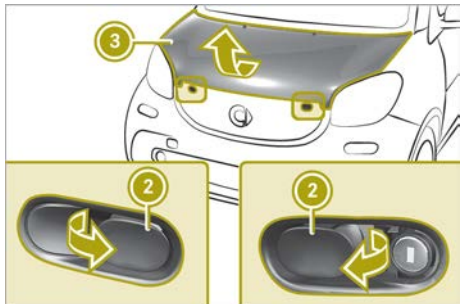

- ▶ Pull both levers (2) in the direction of the arrow.
- ▶ Lift service cover (3) at the front.
- ▶ Pull service cover (3) slightly forwards and upwards to remove it.
- ▶ Hook top rear of service cover (3) into the openings on the vehicle.

Closing the service cover

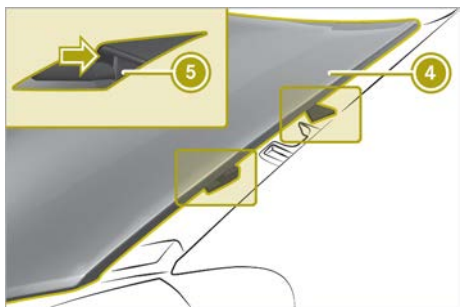

- ▶ Lift service cover (3).
- ▶ Slide bars (5) on the left and right of the service cover under the bars on wing (4).

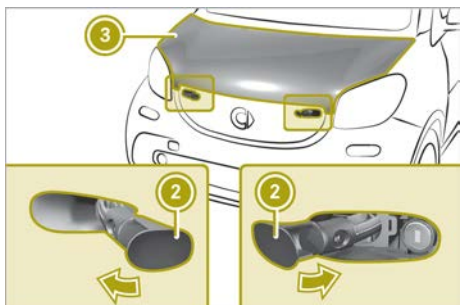

- ▶ Press service cover (3) downwards.
- ▶ Press both levers (2) backwards in the direction of the arrow.

Locking the service cover on vehicles with a lockable service cover

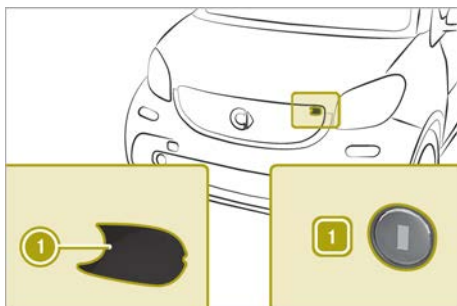

- ▶ Insert the key into the lock and turn it to position 1.
- ▶ Insert lock cover (1) on the driver's side and snap it into place.

Checking service products and topping up

Please note

⚠ WARNING

Service product can be poisonous and hazardous to health. There is a risk of injury. Observe the instructions on the respective original container when using, storing and disposing of service products. Always store service products in the sealed original container. Always keep service products out of the reach of children.

♻ Environmental note

Dispose of service products in an environmentally-responsible manner.

Also observe the safety notes in the "Service products" section (▷ page 190).

Service products include the following:

- Fuels (e.g. petrol, diesel)
- Lubricants (e.g. engine oil, transmission oil)
- Coolant
- Brake fluid
- Windscreen washer fluid
- Climate control system refrigerant

Service products approved by smart: <http://bevo.mercedes-benz.com>

Checking the engine oil and topping up

Checking the engine oil level

WARNING

Certain components in the engine compartment could be very hot, e.g. the engine, the radiator and parts of the exhaust system. There is a risk of injury when accessing the engine compartment.

As far as possible, allow the engine to cool down and only touch the components described in the following.

WARNING

If you open the bonnet while the engine is overheating or while there is a fire in the engine compartment, you could come into contact with hot gases or other leaking service products. There is a danger of injury.

Allow an overheating engine to cool down before opening the bonnet. If there is a fire in the engine compartment, leave the bonnet closed and notify the fire brigade.

WARNING

There are moving components in the engine compartment. Certain components may continue to move or suddenly move again even after the ignition has been switched off, e.g. the radiator fan. There is a risk of injury.

If you have to carry out work in the engine compartment:

- switch off the ignition
- never touch the dangerous areas surrounding moving components, e.g. the rotation area of the fan
- remove jewellery and watches
- keep items of clothing and hair, for example, away from moving parts.

Depending on your driving style, the vehicle consumes up to 0.5 litres of oil per 1000 km. The oil consumption may be higher than this when the vehicle is new or if it is frequently driven at high engine speeds.

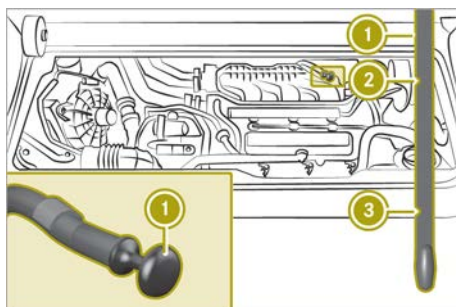

To check the engine oil, the vehicle must be parked on a flat surface.

- ▶ If the engine has not been started for an extended period, e.g. overnight, the measurement can be carried out immediately.
- ▶ If the engine is at normal operating temperature, wait 5 minutes before measuring.
- ▶ If the engine was only started briefly and is not at normal operating temperature, switch off the engine and wait 30 minutes before carrying out the measurement.
- ▶ Open the engine dipstick compartment cover.
- ▶ Remove oil dipstick ① from the guide tube and wipe it off.
- ▶ Insert the oil dipstick fully into the guide tube.
- ▶ Pull out the oil dipstick.
- ▶ Read the engine oil level. The level must be between MIN ③ and MAX ②.

Adding engine oil

WARNING

If engine oil comes into contact with hot components in the engine compartment, it may ignite. There is a risk of fire and injury.

Make sure that engine oil does not spill out over the filler neck. Allow the engine to cool down and thoroughly clean the components that have come into contact with engine oil before you start the engine.

! Do not add too much oil. If the oil level is above the **MAX** mark on the dipstick, too much oil has been added. This can lead to engine damage or catalytic converter damage. Have excess oil siphoned off.

! Do not use any additives with the engine oil. This could damage the engine.

Environmental note

When topping up the oil, take care not to spill any. If oil enters the soil or waterways, it is harmful to the environment.



Information on tested and approved engine oils is available from any smart centre. smart recommends that you have the oil change carried out at a qualified specialist workshop.

Overview of approved engine oils: <http://bevo.mercedes-benz.com>, then enter the designation, e.g. 229.5.

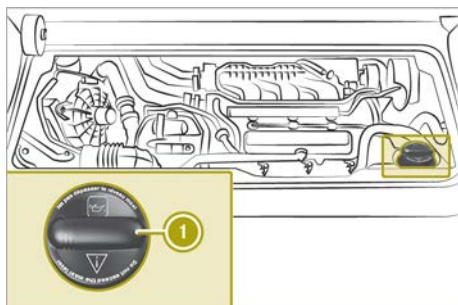

- ▶ Unscrew and remove cap ①.
 - ▶ Top up with no more than 1 litre of recommended engine oil.
 - ▶ Replace the cap and tighten it as far as it will go.
 - ▶ Check the engine oil level.
 - ▶ Close the engine compartment cover.
- i** Regular engine oil changes using an approved engine oil from the suitable SAE classification are strongly recommended.

Checking the coolant and topping up

Checking the coolant level

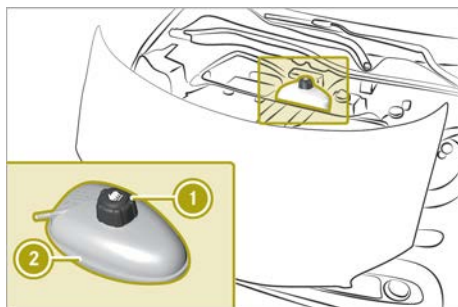

- ▶ Stop the vehicle on a level surface.
- ▶ Let the coolant cool down for at least 30 minutes.
- ▶ Open the service cover.
- ▶ Check reservoir ② visually. The fluid level must be between the MIN mark and the MAX mark.

Topping up the coolant

WARNING

The cooling system is pressurised, particularly when the engine is warm. If you open the cap, you could be scalded if hot coolant sprays out. There is a risk of injury. Let the engine cool down before you open the cap. Wear gloves and eye protection. Open the cap slowly to release the pressure.

! Only add coolant that has been premixed with the desired antifreeze protection. You could otherwise damage the engine.

Further information on coolants can be found in the Mercedes-Benz Specifications for Service Products, MB Specifications for Service Products 310.1, e.g. on the Internet at <http://bevo.mercedes-benz.com>. Or contact a qualified specialist workshop.

If antifreeze/corrosion inhibitor is present in the correct concentration, the boiling point of the coolant during operation is approximately 130 °C.

The antifreeze/corrosion inhibitor concentration in the engine cooling system should be 50% (antifreeze protection down to -37 °C). This will protect the engine cooling system against freezing down to approximately -25 °C.

- ▶ Cover cap ① of coolant expansion tank ② with a cloth.
- ▶ Turn the cap slowly one half turn. If necessary, allow excess pressure to escape.
- ▶ Turn the cap further and remove it.
- ▶ Top up the coolant to the MAX level.
- ▶ Replace the cap and tighten it as far as it will go.
- ▶ Close the service cover.

i See "Technical data" for information on recommended coolants.

Topping up the washer fluid

WARNING

Windscreen washer concentrate is highly flammable. If it comes into contact with hot

components in the front compartment, it may ignite. There is a risk of fire and injury.

Make sure that windscreen washer concentrate is not spilled next to the filler neck.

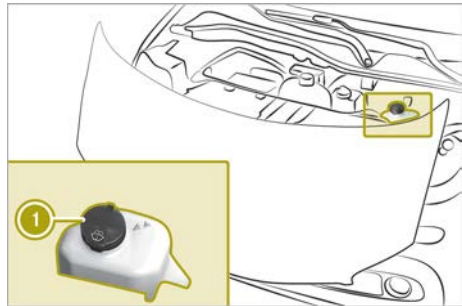

- ▶ Open the service cover.
- ▶ Pull cap ① upwards at the tab.
- ▶ If available, pull the removable nozzle up as far as the stop.
- ▶ Top up with washer fluid.
- ▶ If available, push the removable nozzle down and push it inside.
- ▶ Replace and tightly screw on cap ①.
- ▶ Close the service cover.

i See "Technical data" for information on windscreen washer fluid/antifreeze.

Checking wheels and tyres

Warning

A flat tyre severely impairs the driving, steering and braking characteristics of the vehicle. There is a risk of an accident.

Do not drive with a flat tyre. Immediately replace the flat tyre with your spare wheel, or consult a qualified specialist workshop.

WARNING

Damaged tyres can cause tyre inflation pressure loss. As a result, you could lose control of your vehicle. There is a risk of accident.

Check the tyres regularly for signs of damage and replace any damaged tyres immediately.

 **WARNING**

Insufficient tyre tread will reduce tyre traction. The tyre is no longer able to dissipate water. This means that on wet road surfaces, the risk of aquaplaning increases, in particular where speed is not adapted to suit the driving conditions. There is a risk of accident.

If the tyre pressure is too high or too low, tyres may exhibit different levels of wear at different locations on the tyre tread. Thus, you should regularly check the tread depth and the condition of the tread across the entire width of all tyres.

Minimum tyre tread depth for:

- summer tyres: 3 mm
- M+S tyres: 4 mm

For safety reasons, replace the tyres before the legally prescribed limit for the minimum tyre tread depth is reached.

 If unavoidable, you should drive over obstacles such as kerbs slowly and not at a sharp angle. Otherwise, you may damage the wheels or tyres.

Modification work on the brake system and wheels is not permitted. The use of spacers or brake dust shields is not permitted. This invalidates the general operating permit for the vehicle.

Check the wheels and tyres for damage at least once a month, as well as after driving off-road or on poorly surfaced roads.

Run-in new tyres at moderate speeds for the first 100 km. The tyres only attain their maximum performance after this distance.

Vibrations, audible noises and unusual handling characteristics, e.g. pulling to one side, can indicate damage to wheels or tyres.

If you suspect a tyre defect:

- ▶ Reduce vehicle speed.
- ▶ Stop the vehicle as soon as possible.
- ▶ Check the wheels and tyres for damage. If you find no signs of damage, have the wheels and tyres checked at a specialist workshop.

Changing a wheel

Please note

 **WARNING**

Never interchange the front and rear wheels as they have different dimensions, e.g. size, offset etc. Otherwise, there could be a negative effect on the road holding and you could endanger yourself or others.

 **WARNING**

Exceeding the stated tyre load-bearing capacity and the approved maximum speed could lead to tyre damage or the tyre bursting. There is a risk of accident.

Therefore, only use tyre types and sizes approved for your vehicle model. Observe the tyre load rating and speed rating required for your vehicle.

 **WARNING**

If wheels and tyres of the wrong size are used, the wheel brakes or suspension components may be damaged. There is a risk of an accident.

Always replace wheels and tyres with those that fulfil the specifications of the original part.

When replacing wheels, make sure to fit the correct:

- designation
- type

When replacing tyres, make sure to fit the correct:

- designation
- manufacturer
- type

I On vehicles fitted with a tyre pressure monitor, electronic components are located in the wheel.

Tyre-fitting tools should not be applied in the area of the valve, since this could damage the electronic components.

Only have tyres changed at a qualified specialist workshop.

I Position a suitable jack only on the jacking points intended for this purpose. Raise the vehicle for a short time only to change the wheel. Make sure the vehicle is on a suitable surface and that no-one is in the vehicle. Secure the vehicle using chocks and apply the parking brake.

Rules for selecting new tyres

I For safety reasons, smart recommends that you only use tyres and wheels which have been specifically approved by smart for your vehicle. These are specially adapted to the control systems, such as ABS or ESP®.

Only use tyres and wheels specifically tested and approved by smart. Certain characteristics, e.g. handling, vehicle noise emissions or fuel consumption, may otherwise be adversely affected. In addition, when driving with a load, dimensional variations and different tyre deformation characteristics could cause the tyres to make contact with the bodywork and axle components. This could result in damage to the tyres or the vehicle.

smart accepts no liability for damage resulting from the use of tyres or wheels other than those tested and approved.

Information on wheels and tyres can be obtained at a qualified specialist workshop, e.g. a smart centre.

The service life of tyres depends on various factors, including the following:

- Driving style
- Tyre pressure
- Mileage

Observe the following rules for selecting new tyres:

- Observe country-specific regulations which stipulate or recommend a certain tyre type for the vehicle.
- Only fit tyres and wheels of the same type and make.
- Only tyres of the same size may be used on a single axle (left/right).
- Only use tyres of the same type (summer tyres, winter tyres).
- Use only wheel-tyre combinations approved by smart.
- Do not wear tyres out too much. This otherwise significantly reduces the traction on wet roads (aquaplaning).
- Replace tyres after six years at the latest.

i Recommended tyre pressures for various operating states can be found on the tyre pressure table on the driver's side door pillar (B-pillar).

You can find further information regarding tyres and wheels at specialist tyre retailers, at qualified specialist workshops and at any smart centre.

Preparing to change a wheel

- ▶ Stop the vehicle on solid, non-slippery and level ground.
- ▶ Apply the parking brake.
- ▶ Position the front wheels to point straight ahead.
- ▶ **Vehicles with a manual transmission:** depress the clutch pedal and shift to either first or reverse gear.
- ▶ **Vehicles with automatic transmission:** shift the transmission to position P.
- ▶ Switch off the engine.
- ▶ Remove key from ignition lock.
- ▶ Secure the vehicle against rolling away.

Removing a wheel

⚠ WARNING

If you do not position the jack correctly at the appropriate jacking point of the vehicle, the jack could tip over with the vehicle raised. There is a risk of injury.

Only position the jack at the appropriate jacking point of the vehicle. The base of the jack must be positioned vertically, directly under the jacking point of the vehicle.

- !** Do not place wheel bolts in sand or dirt. The threads of the wheel bolts and wheel hubs could otherwise be damaged when the bolts are tightened.

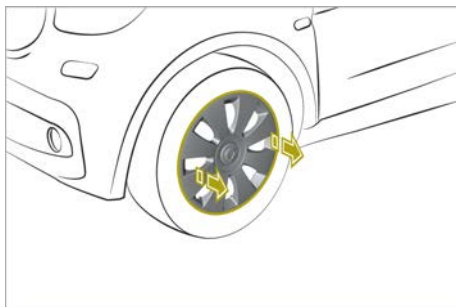

Vehicles with steel wheels and hub caps:

- Using both hands, grasp two hub cap openings and remove the hub cap.

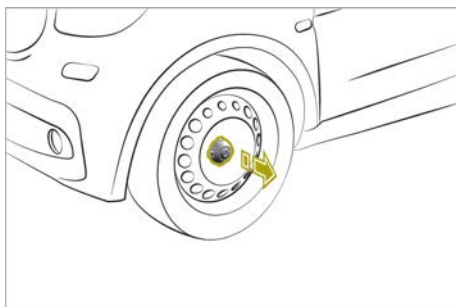

Vehicles with steel wheels and hub cap covers:

- Remove the wheel hub cover.

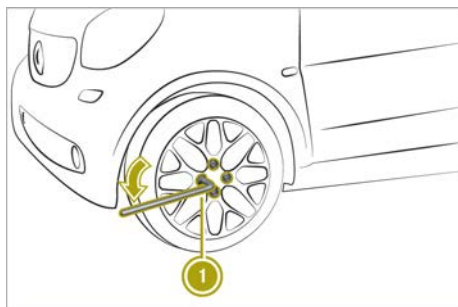

- Using wheel wrench ① loosen the wheel bolts by about one turn. Do not unscrew the wheel bolts completely.

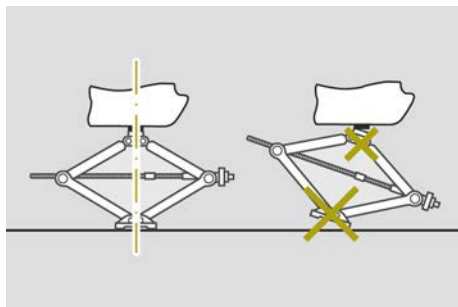
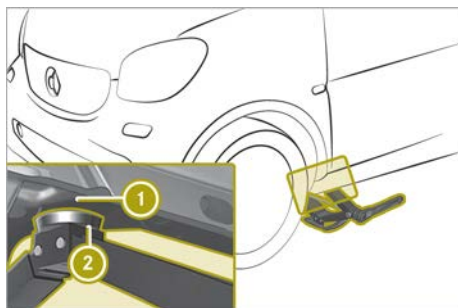
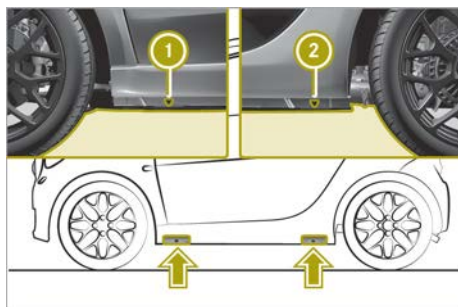

The vehicle may only be raised at the designated jacking points. The jacking points are located just behind the front wheel arches and just in front of the rear wheel arches.

- ▶ Position jack ② under the triangular indentations for jacking point ①.
- ▶ Set the foot of the jack up vertically with respect to the jacking point on the vehicle.
- ▶ Raise the vehicle with the jack until the tyre is at most 3 cm off the ground.
- ▶ Unscrew and remove the wheel bolts.
- ▶ Remove the wheel.



Fit tyres with a specified direction of rotation only according to their direction of rotation. An arrow on the sidewall of the tyre indicates its correct direction of rotation.

- ▶ Clean the wheel and wheel hub contact surfaces.
- ▶ Push the wheel onto the wheel hub and press it on.
- ▶ Screw in the wheel bolts and tighten them slightly.

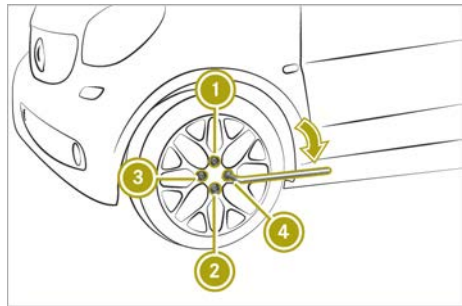

- ▶ Lower the vehicle all the way.
- ▶ Remove the jack.
- ▶ Tighten the wheel bolts evenly in a cross-wise pattern in sequence indicated ① to ④. The tightening torque must be 105 Nm.
- ▶ Check the recommended tyre pressure and adjust if necessary.

i Vehicles with tyre pressure control system: all fitted wheels must be equipped with functioning sensors.

Fitting a wheel

⚠ WARNING

Oiled or greased wheel bolts or damaged wheel bolts/hub threads can cause the wheel bolts to come loose. As a result, you could lose a wheel while driving. There is a risk of accident.

Never oil or grease wheel bolts. In the event of damage to the threads, contact a qualified specialist workshop immediately. Have the damaged wheel bolts or hub threads replaced/renewed. Do not continue driving.

⚠ WARNING

The wheels could work loose if the wheel nuts and bolts are not tightened to the specified tightening torque. There is a risk of accident.

Have the tightening torque immediately checked at a qualified specialist workshop after a wheel is changed.

⚠ WARNING

If you tighten the wheel bolts or wheel nuts when the vehicle is raised, the jack could tip over. There is a risk of injury.

Only tighten the wheel bolts or wheel nuts when the vehicle is on the ground.

- !** When changing a wheel, use only wheel bolts that have been approved for the wheel rim and vehicle.

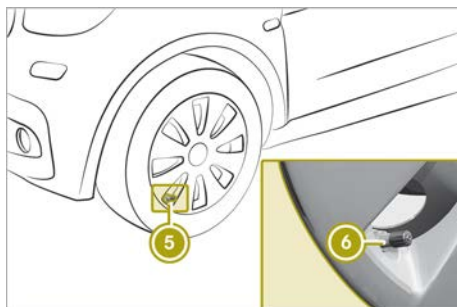

Vehicles with steel wheels and hub caps:

- ▶ Fit hub cap (5) such that valve (6) does not become trapped.
- ▶ Press the hub cap evenly onto the wheel with both hands until you hear the hub cap engage.
- ▶ Check to make sure the hub cap is seated securely on the wheel.

Vehicle with steel wheels and wheel hub covers:

- ▶ Fit the wheel hub cover.

Storing wheels

- ▶ Store wheels in a cool, dry and dark place when not in use.
- ▶ Protect against oil, grease and fuel.

Using the tyre pressure monitor

Useful information

It is the driver's responsibility to set the tyre pressure to the recommended cold tyre pressure suitable for the operating situation.

The tyre pressure monitor issues a warning when the pressure drops in one or more of the tyres.



The tyre pressure monitor works properly only if sensors are present in all four tyres, and after the monitor has learned the correct tyre pressure for the current operating situation. This occurs automatically in most situations, but may also be specified after restarting the tyre pressure monitor. Before restarting, check the tyres for the recommended tyre pressure.

The tyre pressure monitor does not provide a warning in the following cases:

- Even loss of pressure on multiple tyres
- Sudden loss of tyre pressure, e.g. due to penetration by a foreign body
- Incorrectly set tyre pressure

The tyre pressure monitor has a yellow warning lamp in the instrument cluster for indicating a pressure loss or malfunction.

Restarting the tyre pressure monitor (on-board computer with a monochrome display)

- ▶ Set the tyre pressure of all tyres to the recommended value.
- ▶ On the multifunction lever press the  button repeatedly until the **SET** and  symbols are displayed in the instrument cluster display.
- ▶ Press and hold the **OK** button on the multifunction lever.
The **SET** and  symbols will flash in the instrument cluster display for about 5 seconds. The two symbols then light up.

The tyre pressure monitor is restarted.

Restarting the tyre pressure monitor (on-board computer with colour display)

- ▶ Set the tyre pressure of all tyres to the recommended value.
- ▶ Select **Settings > Tyre pressure monitor** in the on-board computer.
The **Tyre pressure monitor Adopt current pressures as new reference values?** message appears in the display.
- ▶ Select **yes** and press **OK** to confirm.
The display shows the **Tyre pressure monitor restarted** message.

If the **Tyre pressure monitor restarted** message does not appear after 5 seconds, repeat the tyre pressure monitor restart.

Checking the tyre pressures

Please note

WARNING

Underinflated or overinflated tyres pose the following risks:

- the tyres may burst, especially as the load and vehicle speed increase.
- the tyres may wear excessively and/or unevenly, which may greatly impair tyre traction.
- the driving characteristics, as well as steering and braking, may be greatly impaired.

There is a risk of an accident.

Observe the recommended tyre pressure and check the tyre pressure of all the tyres:

- at least every two weeks
- when the load changes
- before embarking on a longer journey
- for changed operating conditions, e.g. off-road driving

If necessary, correct the tyre pressure.

WARNING

If you mount unsuitable accessories onto tyre valves, the tyre valves may be overloaded and malfunction, which can cause tyre pressure loss. Aftermarket tyre pressure monitoring systems will cause the tyre valve to remain open. This can also result in tyre pressure loss. There is a risk of an accident.

Only screw standard valve caps or valve caps specifically approved by smart for your vehicle onto the tyre valve.

WARNING

If the tyre pressure drops repeatedly, the wheel, valve or tyre may be damaged. Tyre pressure that is too low may result in a tyre blow-out. There is a risk of accident.

- Check the tyre for foreign objects.
- Check whether the wheel is losing air or the valve is leaking.

If you are unable to rectify the damage, contact a qualified specialist workshop.

Environmental note

Check the tyre pressure regularly, at least every 14 days.

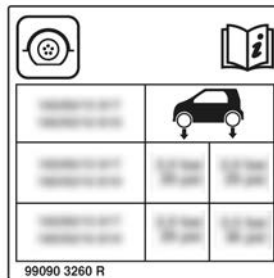

The table with the recommended tyre pressure for various operating conditions can be found on the driver's side door pillar (B-pillar).

The tyre pressure table may also state air pressures for different load conditions. These are defined in the table as different numbers of passengers and amounts of luggage. The actual number of seats may differ from this.

If a tyre size precedes a tyre pressure, the tyre pressure information following is only valid for that tyre size. If tyre sizes are not specified, the tyre pressures stated on the tyre pressure table apply for all approved tyres.

Checking and correcting the tyre pressure manually

Only check the tyre pressure once the tyres have cooled down.

- ▶ Drive the vehicle less than 2 km.
- ▶ Park the vehicle away from direct sunlight for at least three hours.
- ▶ Check the tyre pressure with a suitable tyre pressure gauge.

- ▶ If necessary, adjust the tyre pressure.
- ▶ Restart tyre pressure monitor.

Using winter tyres

WARNING

M+S tyres with a tyre tread depth of less than 4 mm are not suitable for use in winter as they do not provide sufficient traction. There is a risk of accident.

M+S tyres with a tread depth of less than 4 mm must be replaced.

At temperatures below +7 °C, summer tyres lose elasticity and therefore traction and braking power. Change the tyres on your vehicle therefore to M+S tyres. Using summer tyres at very cold temperatures could cause tears to form, thereby damaging the tyres permanently. smart cannot accept responsibility for this type of damage.

Have the vehicle winterproofed at a qualified specialist workshop at the onset of winter.

- ▶ At low temperatures, use only winter tyres marked with M+S.
- ▶ When road conditions are wintry, use M+S tyres with the additional  snowflake symbol. These tyres allow driving safety systems, e.g. ABS, to function optimally in the winter.
- ▶ Use M+S tyres of the same make and tread on all wheels.
- ▶ When driving with M+S tyres, observe the specified maximum permissible speed.
- ▶ Use only tyre types and sizes approved for smart.
- ▶ When using tyres with a specified direction of rotation, observe the arrow on the sidewall indicating the tyre's direction of rotation.

After fitting M+S tyres:

- ▶ Check tyre pressure.
- ▶ Restart tyre pressure monitor.
- ▶ If M+S tyres with a lower maximum permissible speed than that of the vehicle are fitted, affix an appropriate warning label in the driver's field of vision. Using the

limiter, restrict the speed to the maximum permissible speed for M+S tyres.

Using snow chains

WARNING

If you have fitted snow chains to the front wheels, they may scrape against the vehicle body or chassis components. This could cause damage to the vehicle or the tyres. There is a risk of an accident.

To avoid hazardous situations:

- never fit snow chains on the front wheels
- fit snow chains to the rear wheels in pairs.

! **Vehicles with steel wheels:** if you fit snow chains on steel wheels, you may damage the hub caps. Remove the hub caps from the relevant wheels before fitting the snow chains.

For safety reasons, smart recommends that you only use snow chains that have been specially approved for your vehicle by smart. Further information can be obtained at a smart centre or a qualified specialist workshop.

- ▶ Observe country-specific regulations.
- ▶ Use only snow chains approved for smart.
- ▶ Fit snow chains on both rear wheels.
- ▶ Use snow chains only on snow-covered roads.
- ▶ When driving with snow chains fitted, do not exceed the maximum permissible speed of 50 km/h.

Changing the window wiper blades

Please note

WARNING

If the windscreen wipers begin to move while you are changing the wiper blades, you can be trapped by the wiper arm. There is a risk of injury.

Always switch off the windscreen wipers and ignition before changing the wiper blades.

! Never open the service cover or tailgate if a wiper arm has been folded away from the windscreen or rear window. Never fold a wiper arm without a wiper blade back onto the windscreen or rear window. Hold the wiper arm firmly when you change the wiper blade. If you release the wiper arm without a wiper blade and it falls onto the window, the window may be damaged by the force of the impact.

Changing the window wiper blades on the windscreen

- ▶ Turn the key to position 1 or 2 in the ignition lock.
- ▶ Press the combination switch to position 2. The wiper arms will move upwards.
- ▶ Turn the key to position 0 and remove it.
- ▶ Fold the wiper arm away from the windscreen.

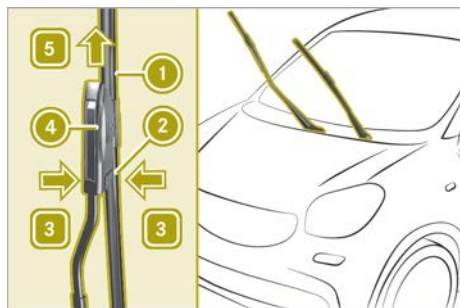

- ▶ Press both release clips ② on mounting ④ in the direction of arrow ③ and pull away from the wiper arm.
- ▶ Slide window wiper blade ① in the direction of arrow ⑤ until the securing hook for the window wiper blade is revealed.
- ▶ Remove the window wiper blade.

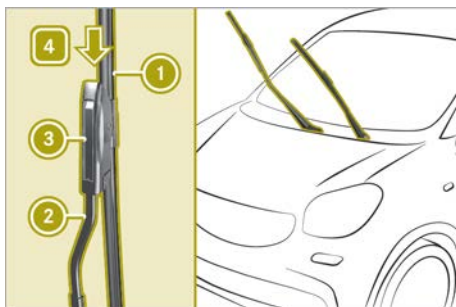

- ▶ Slide new window wiper blade ① in the direction of arrow ④ onto mounting ③ of wiper arm ②.
- The window wiper blade snaps into place.
- ▶ Check that the window wiper blade is positioned correctly.
- ▶ Carefully fold wiper arm ② onto the windscreen.

Changing the rear window wiper blade (smart fortwo coupé)

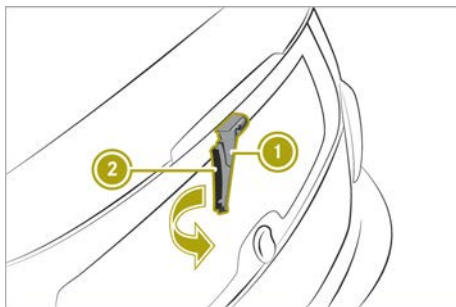

- ▶ Remove key from ignition lock.
- ▶ Fold wiper arm ① away from the rear window until you hear it engage.
- ▶ Unscrew window wiper blade ② in the direction of the arrow until it is released from the retainer on the wiper arm.
- ▶ Pull out window wiper blade ②.
- ▶ Press new window wiper blade ② onto wiper arm ① until it engages.
- ▶ Check that window wiper blade ② is positioned correctly.
- ▶ Fold wiper arm ① back onto the rear window.

Cleaning the vehicle

Useful information

Regular care maintains the appearance and quality of the vehicle over time.

Observe the following when cleaning and caring for the vehicle:

- ▶ Use soft, moist cloths.
- ▶ Use care products and cleaning agents recommended and approved by smart.
- ▶ Do not use acidic cleaning agents.
- ▶ In winter, carefully remove road salt as soon as possible.

Cleaning the vehicle exterior

Cleaning the vehicle

Preparing the vehicle for cleaning

WARNING

Braking efficiency is reduced after the vehicle has been washed. There is a risk of an accident.

After washing the vehicle, brake carefully while paying attention to the traffic conditions in order to restore full braking efficiency.

- ▶ Close the side windows completely.
- ▶ Switch off the climate control blower.
- ▶ Turn the windscreen wipers to position 0.

Cleaning in an automatic car wash

- ▶ Prepare the vehicle for cleaning.
- ▶ Remove excess dirt.
- ▶ Drive through the automatic car wash.
- ▶ Remove wax from the front windscreen and the wiper blades.

i If the windscreen wipers leave smears after the vehicle has passed through the car wash, this may be caused by wax or other residue. This residue can be removed with washer fluid.

Washing by hand

- ▶ Locate a washing bay equipped for hand-washing.
- ▶ Prepare the vehicle for cleaning.
- ▶ Apply mild cleaning agent with a soft vehicle sponge.
- ▶ Thoroughly hose the vehicle with a gentle jet of water; do not point the water jet directly towards the air inlet grille.
- ▶ Dry the vehicle off with a chamois.

Cleaning with a high-pressure cleaner

WARNING

The water jet of circular-jet nozzles (dirt grinders) can cause damage not visible from the outside to tyres or chassis components. Components damaged in this way can unexpectedly fail. There is a risk of an accident.

Do not use high-pressure cleaners with circular-jet nozzles to clean the vehicle. Have damaged tyres or chassis components replaced immediately.

! Always maintain a distance of at least 30 cm between the vehicle and the high-pressure cleaner nozzle. Information about the correct distance is available from the equipment manufacturer.

Move the high-pressure cleaner nozzle around when cleaning your vehicle.

Do not aim directly at any of the following:

- tyres
- door gaps, roof gaps, joints etc.
- electrical components
- battery
- connectors
- lights
- seals
- ventilation slots

Damaged seals or electrical components can lead to leaks or failures.

- ▶ Prepare the vehicle for cleaning.
- ▶ Maintain a distance of at least 30 cm between the high-pressure cleaner nozzle and the vehicle.
- ▶ Keep moving the nozzle whilst cleaning.

Cleaning the reversing camera

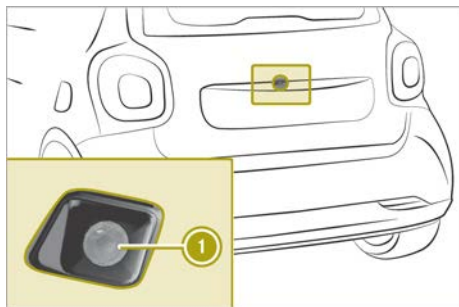

- ▶ Clean camera lens ① with water and a soft cloth.

Cleaning the sensors

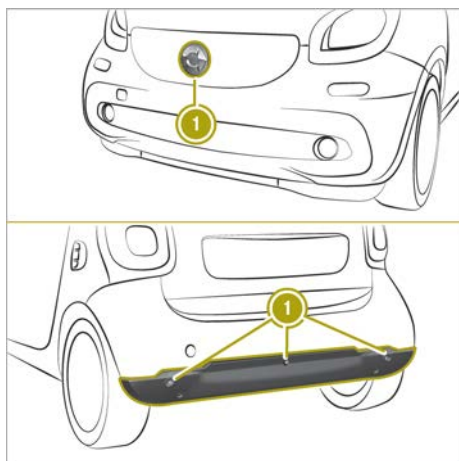

- ▶ Clean sensors ① with water, car shampoo and a soft cloth.

Cleaning the wheels

WARNING

The water jet of circular-jet nozzles (dirt grinders) can cause damage not visible from the outside to tyres or chassis components. Components damaged in this way can unexpectedly fail. There is a risk of an accident.

Do not use high-pressure cleaners with circular-jet nozzles to clean the vehicle.

Have damaged tyres or chassis components replaced immediately.

- ❗ Do not use acidic wheel cleaning products to remove brake dust. This could damage wheel bolts and brake components.
- ❗ Do not park up your vehicle for a long period of time immediately after cleaning, particularly after cleaning the wheel rim with wheel cleaner. Wheel cleaner may lead to increased corrosion of the brake discs and pads. You should therefore drive for a few minutes after cleaning. By heating up the brakes, the brake discs and pads dry. The vehicle can then be parked up for a long period of time.
- ▶ Clean the wheels with an acid-free cleaning agent.

Cleaning the exhaust pipe

- ❗ Do not clean the exhaust pipe with acid-based cleaning agents, such as sanitary cleanser or wheel cleaner.
- ▶ Clean the exhaust pipe with an acid-free cleaning agent.

Cleaning the windows and windscreen wipers

Cleaning the windows

WARNING

If the windscreen wipers are set in motion when cleaning the windscreen or wiper blades, you could become trapped. There is a danger of injury.

Always switch off the windscreen wipers and the ignition before cleaning the windscreen or wiper blades.

- ▶ Place the wiper arms in the vertical position and fold them away from the window.
- ▶ Clean the inside and outside of the windows with a damp cloth and a cleaning agent recommended by smart.
- ▶ Clear deposits regularly from the windscreen and rear window to ensure that water can drain unhindered.

Cleaning the window wiper blades

- ▶ Place the wiper arms in the vertical position and fold them away from the window.
- ▶ Clean the window wiper blades with a soft cloth.
- ▶ Fold the wiper arms back into place.

Cleaning the panoramic roof (smart fortwo coupé)

- ❗ Only use cleaning agents or cleaning cloths that are suitable for plastic lenses. Unsuitable cleaning agents or cleaning cloths could scratch or damage the plastic panes of the panorama roof. Do not use cleaning agents containing solvents
- ▶ Apply mild cleaning agent for plastic lenses and wipe off with a moist sponge.

Cleaning the solid roof

Dry cleaning

- ▶ Brush from the front to the back using a soft brush.

Wet cleaning

- ▶ Dry clean first.
- ▶ Wash down with a soft brush or sponge and lukewarm water.
- ▶ Rinse with clean water.

Cleaning the soft top (smart fortwo cabrio)

Useful information

- ❗ Never clean the soft top using a high-pressure cleaner as water could otherwise enter the vehicle interior.
- ❗ Only clean the folding roof and the rear soft top when they are closed.

Dry cleaning

- ▶ Brush from the front to the back using a soft brush.

Wet cleaning

- ▶ Dry clean first.
- ▶ Wash down with a soft brush or sponge and lukewarm water.
- ▶ Rinse with clean water.

Cleaning the exterior lighting

- ▶ Apply mild cleaning agent for plastic lenses and wipe off with a wet sponge.

Cleaning and caring for paintwork

- ❗ Do not affix stickers to the painted surface. Adhesive residue could damage the paintwork.
- ▶ Remove impurities immediately by rubbing carefully.
- ▶ Soak insect remains with insect remover and rinse off.
- ▶ Soak bird droppings with water and rinse off.
- ▶ Use tar remover to remove tar stains.
- ▶ Use silicone remover to remove wax.
- ▶ Remove coolant, brake fluid, tree resin, oils, fuels and greases by rubbing carefully with a cloth soaked in petroleum ether or lighter fluid.

Cleaning the vehicle interior

Cleaning the displays

- ❗ For cleaning, do not use any of the following:

- alcohol-based thinner or petrol
- abrasive cleaning agents
- commercially-available household cleaning agents

These may damage the display surface. Do not put pressure on the display surface when cleaning. This could lead to irreparable damage to the display.

- ▶ Switch off the display and let it cool down.
- ▶ Clean the display surface with a microfibre cloth and cleaner for TFT/LC displays.
- ▶ Dry the display surface using a dry microfibre cloth.

Cleaning the steering wheel and gear or selector lever

- ▶ Wipe off with a moist cloth, or use a leather care agent recommended by smart.

Cleaning the seat belts

WARNING

Seat belts may be severely weakened if bleached or coloured. This may lead to the seat belts, for example, tearing or failing in an accident. There is an increased risk of injury, possibly even fatal.

Never bleach or colour seat belts.

! Do not clean the seat belts using chemical cleaning agents. Do not dry the seat belts at temperatures above 80 °C or in direct sunlight.

- ▶ Clean the seat belts using only lukewarm soapy water.

Cleaning and caring for seats

Please note

! Do not use microfibre cloths to clean genuine leather or artificial leather covers, as these are too aggressive and, if used often, may damage the cover.

Regular care maintains the appearance and feel of the seats over time.

Cleaning and caring for genuine leather seat covers

- ▶ Wet a cloth with water and clean the seat covers. Do not allow the leather to become soaked.
- ▶ Wipe off with a dry cloth.
- ▶ Apply a leather care agent recommended by smart.

Cleaning synthetic leather seat covers

- ▶ Wet a cloth with detergent water and clean the seat covers.

Cleaning cloth seat covers

- ▶ Wet a microfibre cloth with detergent water.
- ▶ Rub cloth covers with care, cleaning entire sections of the cover.
- ▶ Allow the seat to dry.

Cleaning DINAMICA seat covers

- ▶ Wet a cloth with water.
- ▶ Clean entire sections of the cover.

Cleaning the artificial leather cover of the dashboard (BRABUS)

- ▶ Wet a cloth with detergent water and clean.

Cleaning the trim

Cleaning the plastic trim

WARNING

Care products and cleaning agents containing solvents can cause surfaces in the cockpit to become porous. This could result in plastic parts breaking away when the airbags are deployed. There is a danger of injury.

Do not use care products and cleaning agents containing solvents to clean the cockpit.

! Do not affix the following to plastic surfaces:

- stickers
- films
- scented oil bottles or similar items

You could otherwise damage the plastic.

To maintain the appearance of high-quality plastic surfaces, do not allow surfaces to come into contact with cosmetics, insect repellents or sun creams.

- ▶ Clean the plastic trim with a damp cloth.
- ▶ Use care products and cleaning agents recommended by smart to remove heavy soiling.

Cleaning the roof lining (smart fortwo coupé)

- ▶ Remove heavy soiling using a soft brush or a cleaning agent recommended by smart.



Cleaning the carpets



- ▶ Use carpet and textile cleaning agents recommended by smart.

Cleaning the trim elements

- ❗ Do not use solvent-based cleaning agents such as tar remover, wheel cleaners, polishes or waxes. There is otherwise a risk of damaging the surface.
- ▶ Clean the trim elements with a moist microfibre cloth.
- ▶ Use care products and cleaning agents recommended by smart to remove heavy soiling.

Observing service due dates

The  and  indicator lamps in the instrument cluster display are reminders of upcoming service due dates:

- : minor service.
- : major service.

Monochrome display: the indicator lamp flashes for a few seconds after the engine is started. Depending on the operating conditions of the vehicle, the time or distance remaining until the service is due, is also displayed.

The service interval is based on normal operation of the vehicle. Observe the following if the vehicle is operated under arduous conditions or increased loads, e.g. regular city driving with frequent intermediate stops:

- ▶ Carry out service work more often than specified by the service interval.
- ▶ Have the air filter, engine oil and oil filter changed more frequently.
- ▶ Check the tyres more frequently.

Current information on the type of service can be obtained at a smart centre or a qualified specialist workshop.

Parking up the vehicle

- ❗ Please note that if the vehicle is not used for prolonged periods, vehicle damage may occur and the battery may discharge or become damaged.
- ▶ Visit a qualified specialist workshop for a consultation.

Securing the vehicle in the event of an accident or a breakdown

Securing the vehicle

- ❗ When a tyre is damaged, the danger area must be kept clear of all persons.
- ▶ Stop the vehicle away from traffic on solid, non-slippery ground.
- ▶ Switch on the hazard warning lamps.
- ▶ Turn the front wheels to the straight-ahead position.
- ▶ Switch off the engine.
- ▶ Passengers should leave the vehicle.
- ▶ Secure the vehicle against rolling away.
- ▶ Set up the warning triangle.

In the event of a flat tyre, without TIREFIT the vehicle cannot be made roadworthy again using the on-board equipment. You cannot place an emergency call using the smart Audio-System. The vehicle owner and the driver are responsible for equipping the vehicle with an appropriate breakdown kit and seeking assistance in the event of a breakdown.

Switching the hazard warning lamps on and off

If the hazard warning lamps are activated, all turn signals flash.

The hazard warning lamps automatically switch on in the following cases:

- an airbag is deployed.
- the vehicle decelerates rapidly from a speed of more than 70 km/h and comes to a standstill.

The hazard warning lamps switch off automatically if a speed of 10 km/h is exceeded again after full brake application.

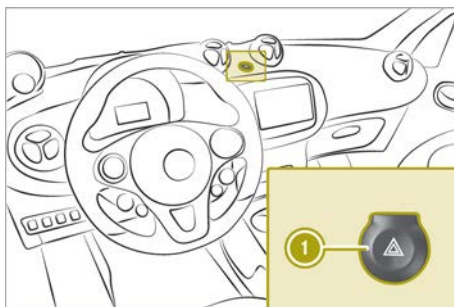

- ▶ Press button ①.

Securing the vehicle against rolling away

Securing on level ground

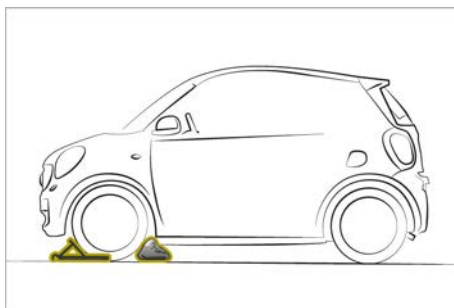

- ▶ When changing a wheel, place chocks or other suitable items under the front and rear of the wheel that is diagonally opposite the wheel you wish to change.

Securing on a downhill gradient

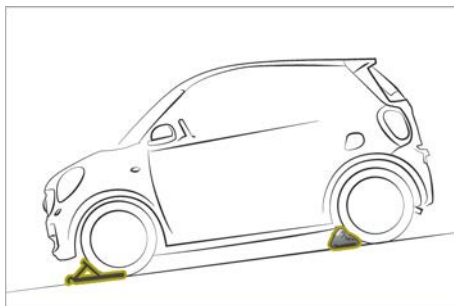

- ▶ Place wheel chocks or other suitable items in front of the wheels of the front and rear axle.

Using the warning triangle

Removing the warning triangle

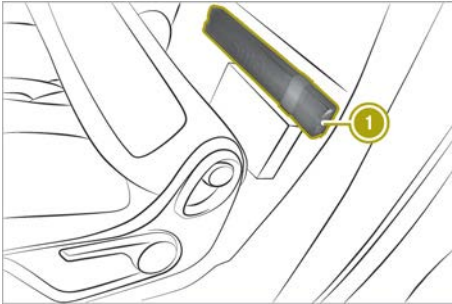

The warning triangle is secured behind the driver's seat backrest with a Velcro fastener.

- ▶ Fold the driver's seat forwards.
- ▶ Remove warning triangle ①.

Setting up the warning triangle



- ▶ Fold feet ③ out to the side.
- ▶ Pull side reflectors ② upwards to form a triangle.
- ▶ Connect the reflectors using upper stud ①.
- ▶ Place the warning triangle at a suitable distance.

Removing the first-aid kit

- ⓘ Check the expiry date on the first-aid kit at least once a year. Replace the contents if necessary, and replace any missing parts.

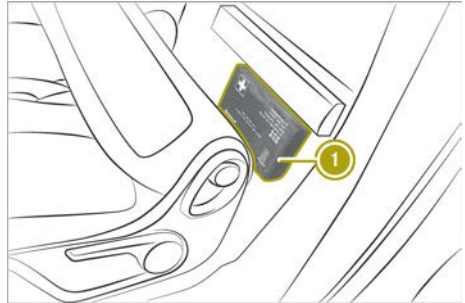

The first-aid kit is secured behind the driver's seat backrest with a Velcro fastener. Return it to this location after use.

- ▶ Fold the driver's seat forwards.
- ▶ Remove first-aid kit ①.

Removing the fire extinguisher

The fire extinguisher is located underneath the front passenger seat.

Removing the vehicle tool tray

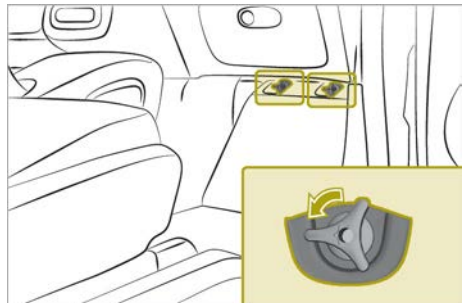

The towing eye and the TIREFIT kit are located in the vehicle tool tray under the glove compartment.

- ▶ Remove bolts in the front-passenger footwell.
- ▶ Remove the vehicle tool tray.

Sealing tyres using the TIREFIT kit

Useful information

The tyre sealant is pumped into the tyre. TIREFIT is a tyre sealant. TIREFIT is used to seal punctures of up to 4 mm, particularly those in the tyre tread, at outside temperatures of up to -20 °C.

Please note

WARNING

In the following situations, the tyre sealant is unable to provide sufficient breakdown assistance, as it is unable to seal the tyre properly:

- there are cuts or punctures in the tyre larger than those mentioned above.
- the wheel rim is damaged.
- you have driven at very low tyre pressures or on a flat tyre.

There is a risk of an accident.

Do not drive any further. Contact a qualified specialist workshop.

WARNING

The tyre sealant is harmful and causes irritation. It must not come into contact with your skin, eyes or clothing or be swallowed. Do not inhale TIREFIT fumes. Keep tyre sealant away from children. There is a risk of injury.

If you come into contact with the tyre sealant, observe the following:

- Rinse off the tyre sealant from your skin immediately with water.
- If the tyre sealant comes into contact with your eyes, immediately rinse them thoroughly with clean water.
- If tyre sealant is swallowed, immediately rinse your mouth out thoroughly and drink plenty of water. Do not induce vomiting, and seek medical attention immediately.

- Immediately change out of clothing which has come into contact with tyre sealant.
- If an allergic reaction occurs, seek medical attention immediately.

WARNING

A tyre temporarily sealed with tyre sealant impairs the driving characteristics and is not suitable for higher speeds. There is a risk of accident.

You should therefore adapt your driving style accordingly and drive carefully. Do not exceed the specified maximum speed with a tyre that has been repaired using tyre sealant.

The maximum permissible speed for a tyre sealed with tyre sealant is 80 km/h.

 After use, excess tyre sealant may run out of the filler hose. This could cause stains. Therefore, place the filler hose in the plastic bag that contained the TIREFIT kit.

Environmental note

Have the used tyre sealant bottle disposed of professionally, e.g. at a qualified specialist workshop.

Comply with the manufacturer's safety instructions on the sticker on the tyre inflation compressor.

Filling with tyre sealant

- ▶ Leave foreign bodies which have penetrated the tyre in the tyre.
- ▶ Remove the vehicle tool tray.
- ▶ Remove the TIREFIT Kit, consisting of a tyre sealant bottle and a tyre inflation compressor, from the vehicle tool kit.
- ▶ Affix the 80 km/h maximum speed sticker to the instrument cluster within the driver's field of vision.

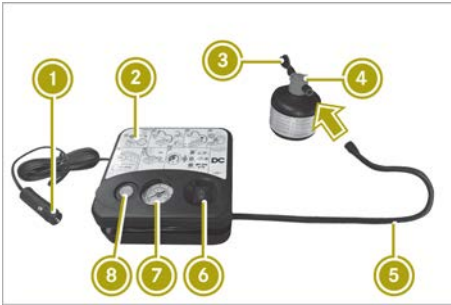

- ▶ Unwind plug ① with the cable from tyre inflation compressor ②.
- ▶ Remove hose ⑤ from the bottom section of tyre inflation compressor ②.
- ▶ Unscrew the cap from tyre sealant bottle ④.
- ▶ Connect hose ⑤.

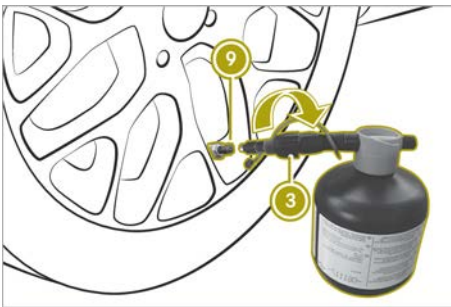

- ▶ Remove valve flap from valve ⑨ on the faulty tyre.
- ▶ Unscrew cap from filler hose ③.
- ▶ Screw filler hose ③ onto valve ⑨.
- ▶ Insert connector ① into the cigarette lighter socket or the 12 V socket.
- ▶ Turn the key in the ignition lock to position 1.
- ▶ Press on/off switch ⑥ on tyre inflation compressor ② to position 1. The tyre sealant is pumped into the tyre. The pressure may briefly rise to approximately 600 kPa (6.0 bar, 86 psi).
- ▶ **i** Preventing damage to the tyre inflation compressor

Do not switch off the tyre inflation compressor during this phase.

- ▶ Let the tyre inflation compressor run for a maximum of 15 minutes, then allow it to cool down.

The tyre pressure must be at least 180 kPa (1.8 bar, 26 psi).

Allow any leaking tyre sealant to dry. It can then be removed like a layer of film.

Have any clothing stained with tyre sealant cleaned as soon as possible with perchloroethylene.

Further procedure if the pressure of the sealed tyre is below 180 kPa

⚠ WARNING

If the specified tyre pressure still cannot be reached, the tyre is too badly damaged. The tyre sealant cannot repair the tyre in this instance. Damaged tyres and low tyre pressures can significantly impair the vehicle's braking and driving characteristics. There is a risk of an accident.

Do not drive any further. Contact a qualified specialist workshop.

- ▶ Switch off the tyre inflation compressor.
- ▶ Unscrew the filler hose from the valve of the defective tyre. Please note that tyre sealant may escape when unscrewing.
- ▶ Slowly move the vehicle approximately 10 m forwards or backwards.
- ▶ Pump up the tyre again. After a maximum of 15 minutes, the tyre pressure must be at least 180 kPa (1.8 bar, 26 psi).

Further procedure if the pressure of the sealed tyre is at least 180 kPa

- ▶ Switch off the tyre inflation compressor.
- ▶ Unscrew the hose from the valve of the defective tyre. Please note that tyre sealant may escape when unscrewing.

- ▶ Stow the tyre sealant bottle and the tyre inflation compressor.
- ▶ Perform a test drive.
The maximum permissible speed for a tyre sealed with tyre sealant is 80 km/h.
- ▶ Stop after driving for approximately 3 km and check the tyre pressure with the tyre inflation compressor.
The tyre pressure must now be at least 130 kPa (1.3 bar/19 psi). The precise values are located on the door pillar (B-pillar) on the driver's side.
- ▶ If necessary, adjust the tyre pressure.
- ▶ Unscrew the filler hose from the valve on the sealed tyre.
Please note that tyre sealant may escape when unscrewing.
- ▶ Screw the valve cap onto the valve of the sealed tyre.
- ▶ Pull the tyre sealant bottle out of the tyre inflation compressor. The filler hose stays on the tyre sealant bottle.
- ▶ Drive to the nearest qualified specialist workshop and have the tyre changed there.
- ▶ Have the tyre sealant bottle and filler hose replaced as soon as possible at a qualified specialist workshop.

Adjusting the tyre pressure

Increasing the tyre pressure

- ▶ Switch on the tyre inflation compressor.
- ▶ Observe the display.

Reducing the tyre pressure



- ▶ Press button ① next to pressure gauge ②.
- ▶ **i** Even unused tyre sealant loses its effectiveness over time.
Have the tyre sealant bottle replaced every four years at a qualified specialist workshop.

Jump-starting and charging the battery

Please note

WARNING

Work carried out incorrectly on the battery can lead, for example, to a short circuit and thus damage the vehicle electronics. This can lead to function restrictions applying to safety-relevant systems, e.g the lighting system, the ABS (anti-lock braking system) or the ESP® (Electronic Stability Program). The operating safety of your vehicle may be restricted.

You could lose control of the vehicle, for example:

- when braking
- in the event of abrupt steering manoeuvres and/or when the vehicle's speed is not adapted to the road conditions

There is a risk of an accident.

In the event of a short circuit or a similar incident, contact a qualified specialist workshop immediately. Do not drive any further. Always have work on the battery carried out at a qualified specialist workshop.

Further information about ABS (▷ page 46) and ESP® (▷ page 47).

WARNING

During charging and jump-starting, explosive gases can escape from the battery. There is a risk of an explosion.

Particularly avoid fire, naked flames, creating sparks and smoking. Ensure there is sufficient ventilation while charging and jump-starting. Do not lean over a battery.

⚠ WARNING

During the charging process, a battery produces hydrogen gas. If a short circuit occurs or sparks are created, the hydrogen gas can ignite. There is a risk of an explosion.

- Make sure that the positive terminal of a connected battery does not come into contact with vehicle parts.
- Never place metal objects or tools on a battery.
- It is important that you observe the described order of the battery terminals when connecting and disconnecting a battery.
- When jump-starting, make sure that the battery poles with identical polarity are connected.
- It is particularly important to observe the described order when connecting and disconnecting the jump leads.
- Never connect or disconnect the battery terminals while the engine is running.

⚠ WARNING

Electrostatic build-up can lead to the creation of sparks, which could ignite the highly explosive gases of a battery. There is a risk of an explosion.

Before handling the battery, touch the vehicle body to remove any existing electrostatic build-up.

⚠ WARNING

Battery acid is caustic. There is a risk of injury.

Avoid contact with the skin, eyes or clothing. Do not breathe in any battery gases. Do not lean over the battery. Keep the batteries out of the reach of children. Immediately rinse off battery acid thoroughly with plenty of clean water and seek medical attention at once.

⚠ WARNING

A discharged battery can freeze at temperatures below freezing point. When jump-starting the vehicle or charging the battery, gases can escape from the battery. There is a risk of an explosion.

Allow the frozen battery to thaw out before charging it or jump-starting.

- If the indicator/warning lamps in the instrument cluster do not light up at temperatures around or below freezing point, it is very likely that the discharged battery has frozen. In this case do not jump-start the vehicle or charge the battery.
- The service life of a battery that has been thawed may be reduced drastically.
- The starting characteristics may be impaired, especially at low temperatures.
- Have the thawed battery checked at a qualified specialist workshop.

! Always have work on the battery carried out at a qualified specialist workshop. Should it, in exceptional circumstances, be absolutely necessary to disconnect the battery yourself, please observe the following:

- switch off the engine and remove the key. Check that all the indicator lamps in the instrument cluster are off. Otherwise, you may damage electronic components such as the alternator, for example.
- first, disconnect the negative terminal clamp, followed by the positive terminal clamp. Never swap the terminal clamps. The vehicle electronics may otherwise be damaged.
- on vehicles with automatic transmission, the transmission is locked in position **P** after disconnecting the battery. The vehicle is secured against rolling away. You can then no longer move the vehicle.

The battery and the cover of the positive terminal clamp must be fitted securely during operation.

! Do not make any attempt to start the vehicle if the on-board voltage is low (e.g. weak lighting) or  is shown in the display. A starting attempt could damage the

batteries if they are cold or not fully charged.

- ❗ Avoid repeated and lengthy starting attempts. Otherwise, the catalytic converter could be damaged by the non-combusted fuel.

📌 Environmental note



Batteries contain pollutants. It is illegal to dispose of them with the household rubbish. They must be collected separately and disposed of in an environmentally responsible recycling system.



Dispose of batteries in an environmentally responsible manner. Take discharged batteries to a qualified specialist workshop or to a collection point for used batteries.

For safety reasons, smart recommends using only batteries which have been approved for your vehicle by smart. These batteries provide increased leakage protection in the event of an accident.

Jump-starting

When jump-starting, observe the following rules:

- Avoid multiple or lengthy starting attempts.
- Do not use a rapid charging device to start the vehicle.
- You may only jump-start the vehicle when the engine and exhaust system are cold.
- For jump-starting, use only batteries with a nominal voltage of 12 V.
- Only use jump leads that have a sufficient cross-section and insulated terminal clamps.
- If the battery is fully discharged, leave the donor battery connected for a few minutes

before attempting to start. This charges the empty battery a little.

- Make sure that the two vehicles do not touch.
- Make sure that the jump leads are not damaged.
- Do not allow non-insulated parts of the terminal clamps to come into contact with other metal parts while the jump leads are connected to the battery.
- The jump leads must not come into contact with parts which can move when the engine is running, e.g. the wiper rods or the fan.
- ▶ Secure the vehicle using the parking brake.
- ▶ Switch off all electrical consumers, e.g. rear window heating or lighting.
- ▶ Turn the key in the ignition lock to position 0.
- ▶ Remove key from ignition lock.
- ▶ Open the service cover.

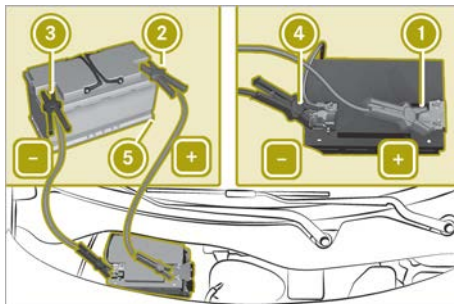

- ⑤ Charged donor battery or an equivalent jump-starting device
- ▶ Remove the protective cap from positive terminal ① of your battery.
- ▶ First connect positive terminal ① of your battery to positive terminal ② of donor battery ⑤ using the jump lead.
- ▶ Start the engine of the donor vehicle and run it at idling speed.
- ▶ First connect negative terminal ③ of donor battery ⑤ and then negative terminal ④ of your battery using the jump lead.
- ▶ Start the engine.
- ▶ Before disconnecting the jump leads, let both engines run for several minutes.

- ▶ To disconnect the jump leads, follow the sequence in reverse.
- ▶ Attach protective cap to positive terminal ①.
- ▶ Have the battery checked at a qualified specialist workshop.

The battery is not accessible in all vehicles. If the other vehicle's battery is not accessible, jump-start the vehicle using a second battery or a jump-starting device.

Charging the battery

In order to prevent damage, observe the following requirements:

- Use only battery chargers with a maximum charging voltage of 14.8 V.
- Charge the battery using only a battery charger approved by smart.
When using another battery charger, remove the battery before charging.
- Observe the operating instructions for the battery charger.
- ▶ Open the service cover.
- ▶ Remove the protective cap from positive terminal ① on the battery.
- ▶ Connect positive terminal ① on the battery to positive terminal ② on battery charger ⑤.
- ▶ Connect negative terminal ③ on battery charger ⑤ to negative terminal ④ on the battery.

The vehicle battery should always be sufficiently charged to achieve the maximum possible service life. The battery may discharge over time if the vehicle is not used.

To charge the battery, a battery charger recommended by smart can be connected.

If the vehicle is unused for an extended period, the battery should be checked frequently or disconnected at a qualified specialist workshop.

A battery charger adapted to and approved by smart allows the charging of the battery in its installed position. Further information is available from any smart Centre.

Towing and tow-starting the vehicle

Please note

WARNING

Safety relevant functions are restricted or no longer available if:

- the engine is not running
- the brake system or power steering is malfunctioning
- there is a malfunction in the voltage supply or the vehicle's electrical system

When your vehicle is towed away or towed started, you may require considerably more effort to steer and brake. There is a risk of an accident.

In such cases use a rigid towing bar. Before being towed away or tow started, make sure the steering moves freely.

WARNING

If the steering wheel lock is engaged, the vehicle can no longer be steered. There is a risk of an accident.

Always switch on the ignition when towing with a tow rope or a towing bar.

WARNING

When towing or tow-starting another vehicle and its weight is greater than the permissible gross weight of your vehicle, the:

- towing eye may be torn off
- car/trailer combination may swerve or even overturn

There is a risk of an accident.

When towing or tow-starting another vehicle, its weight should not be greater than the permissible gross weight of your vehicle.

Information on the vehicle's permissible gross mass can be found on the vehicle identification plate (> page 188).

! Observe the following points when towing with a tow rope:

- secure the tow rope on the same side on both vehicles.
- make sure that the tow rope is not longer than legally permitted. Mark the tow rope in the middle, e.g. with a white cloth (30 x 30 cm). This makes other road users aware that a vehicle is being towed.
- only secure the tow rope to the towing eye.
- observe the brake lamps of the towing vehicle while driving. Always maintain a distance so that the tow rope does not sag.
- do not use steel cables or chains to tow your vehicle. You could otherwise damage the vehicle.

! Do not use the towing eyes for recovery purposes as this could damage the vehicle. If in doubt, recover the vehicle with a crane.

! Pull away smoothly when towing away or tow-starting a vehicle. If the tractive power is too high, the vehicles could be damaged.

! You may tow the vehicle for a maximum of 50km. A towing speed of 50 km/h must not be exceeded.

For towing distances over 50 km, the entire vehicle must be lifted up and transported.

Observe the legal requirements for the relevant countries when towing and tow starting.

Preference should be given to transporting rather than towing.

Vehicles with automatic transmission: when being towed, the transmission must be in position N.

i Before the vehicle is towed, switch off the automatic locking feature. The driver could otherwise be locked out when pushing or having the vehicle towed.

i **Vehicles with the basic carrier fitted:**

Do not tow the vehicle with the basic carrier fitted.

Do not secure the tow rope or tow bar to the basic carrier.

Vehicles with automatic transmission:

observe the notes on the selector lever when towing away the vehicle.

Fitting the towing eye

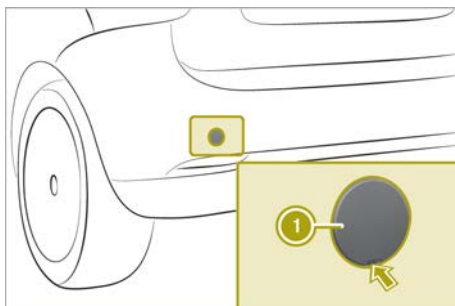
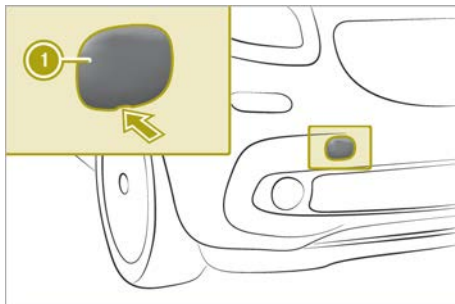

The towing eye can be attached to the front or rear of the vehicle.

- ▶ Remove the towing eye from the vehicle tool tray.
- ▶ Carefully prise off cover ① on the vehicle.
- ▶ Screw in the towing eye to the stop.

Towing the vehicle with both axles on the ground

Vehicles with automatic transmission:

- ▶ Turn the key to position 2 in the ignition lock.
- ▶ Depress the brake pedal and keep it depressed.
- ▶ Shift the automatic transmission to position N. The selector lever lock can be manually released in the event of an electrical malfunction.

- ▶ Release the brake pedal.
- ▶ Release the parking brake.
- ▶ Switch on the hazard warning lights.

Vehicles with manual transmission:

- ▶ Leave the key in position 2 in the ignition lock.
- ▶ Release the brake pedal.
- ▶ Release the parking brake.
- ▶ Switch on the hazard warning lights.

Towing the vehicle with the rear axle raised

- ▶ Switch on the hazard warning lights.
- ▶ Deactivate automatic door locking.
- ▶ Turn the front wheels to the straight-ahead position.
- ▶ **Vehicles with automatic transmission:** turn the key to position 2 in the ignition lock.
- ▶ **Vehicles with automatic transmission:** shift the transmission to position P.
- ▶ **Vehicles with manual transmission:** depress the clutch pedal fully and select neutral.
- ▶ Turn the key to position 0 in the ignition lock and remove it.

Transporting the vehicle

- ! Only lash the vehicle down by the wheels or wheel rims, not by parts of the vehicle such as axle or steering components. The vehicle could otherwise be damaged.
- ▶ **Vehicles with automatic transmission:** turn the key to position 2 in the ignition lock. Move the transmission to position N.
- ▶ **Vehicles with manual transmission:** depress the clutch pedal fully and select neutral.

As soon as the vehicle is loaded:

- ▶ Apply the parking brake.
- ▶ **Vehicles with automatic transmission:** shift the transmission to position P.
- ▶ **Vehicles with manual transmission:** engage first gear.
- ▶ Remove the key.
- ▶ Lash down the vehicle.

Emergency engine starting by tow starting

The following conditions must be met before tow starting:

- The battery is connected.
- The engine has cooled down.
- The exhaust system has cooled down.
- ▶ Switch on the hazard warning lights.
- ▶ Fit the towing eye.
- ▶ Attach the tow bar or tow rope.
- ▶ Depress the brake pedal and keep it depressed.
- ▶ Turn the key to position 2 in the ignition lock.
- ▶ **Vehicles with automatic transmission:** activate the manual gearshift setting.
- ▶ **Vehicles with manual transmission:** depress the clutch pedal fully, engage second gear and keep the clutch pedal fully depressed.
- ▶ Release the brake pedal.
- ▶ Tow start the vehicle.
- ▶ **Vehicles with automatic transmission:** push the selector lever forwards towards  until the engine starts. Do not depress the accelerator pedal while doing so.
- ▶ **Vehicles with manual transmission:** without depressing the accelerator pedal, release the clutch pedal slowly.
- ▶ **Vehicles with manual transmission:** when the engine is started, immediately depress the clutch pedal fully and select neutral.
- ▶ Keep the engine running by accelerating.
- ▶ Pull over at a suitable place and stop the vehicle safely, paying attention to road and traffic conditions.
- ▶ Apply the parking brake.
- ▶ Remove the tow bar or tow rope.
- ▶ Remove the towing eye.

Removing the towing eye

- ▶ Loosen the towing eye and unscrew it.
- ▶ Attach the cover to the recess at the top and engage it at the bottom.
- ▶ Stow the towing eye in the vehicle tool tray.

Manually releasing the selector lever lock

The selector lever lock can be manually released in the event of an electrical malfunction, e.g. if the parking lock has been deactivated for towing and should subsequently be re-applied.

- I** Do not use any sharp-edged objects to prise out the cover from the centre console. Otherwise, the cover or the centre console could be damaged.

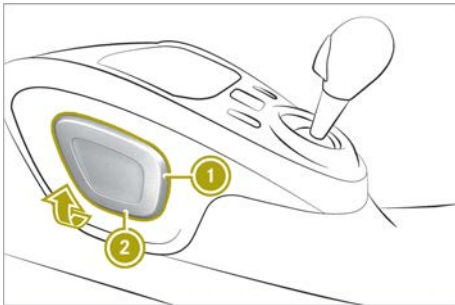

- ▶ Apply the parking brake.
- ▶ Prise out cover ① on the centre console from bottom edge ② using with a flat, blunt object.
- ▶ Pull cover ① in the direction of the arrow.

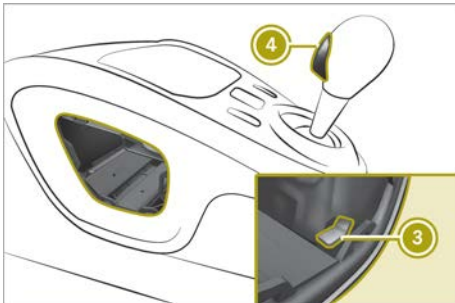

- ▶ Pull yellow release ③ behind the trim up and simultaneously press release button ④ on the selector lever.
- ▶ Shift the selector lever to N or P.

Replacing the bulbs

Useful information

⚠ WARNING

Bulbs, lamps and plug connectors can become very hot during use. When replacing a bulb, you could burn yourself on these components. There is a risk of injury. Allow these components to cool down before replacing the bulb.

⚠ WARNING

The radiator fan may continue to move or suddenly move again even after the engine is switched off. There is a risk of injury. If you have to carry out work in the front compartment:

- switch off the ignition
- remove jewellery and watches
- never touch the rotation area of the fan
- keep items of clothing and hair, for example, away from the fan

Observe the following rules when changing bulbs:

- Only replace bulbs when the engine is switched off.
- Do not use bulbs that have been dropped or show signs of visible damage, e.g. scratches.
- Do not touch the glass bulb with your bare hands.
- Only use bulbs in enclosed lamps designed for that purpose.
- Only fit spare bulbs of the same type and with a specified voltage.
- Do not allow bulbs to come into contact with moisture.
- Have LED bulbs changed at qualified specialist workshops only.

Change only the bulbs described below yourself in accordance with the specified bulb types.

Replacing front bulbs

Changing dipped-beam and main-beam headlamps

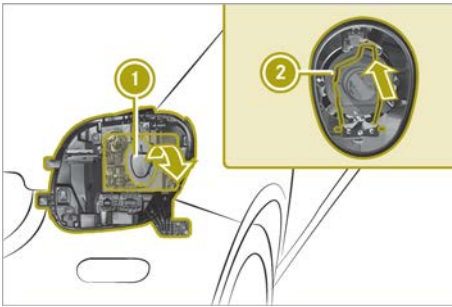

- ▶ Switch off the lights.
- ▶ Open the service cover.
- ▶ Remove cover ①.
- ▶ Pull out the connector.
- ▶ Press retainer ② inwards and to the left.
- ▶ Pull the bulb out.
- ▶ Insert the new bulb.
- ▶ Lock the retainer.
- ▶ Insert the connector.
- ▶ Replace and engage cap ①.

Changing the front turn signal lamps

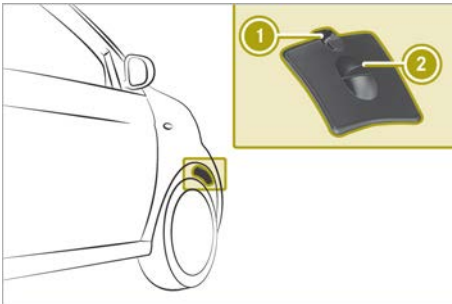

- ▶ Switch off the lights.
- ▶ Turn the respective front wheel inwards.
- ▶ Push clamp ① downwards.
- ▶ Remove cover ② upwards.
- ▶ Turn the bulb holder anti-clockwise and remove it.
- ▶ Remove the bulb from the bulb holder.
- ▶ Insert the new bulb.

- ▶ Insert the bulb holder and turn it clockwise until it engages.
- ▶ Insert and engage the cover.

Replacing the side turn signal lamps

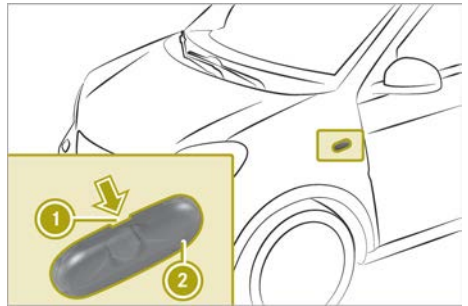

- ▶ Carefully insert a flat tool into recess ①.
- ▶ Pry out side turn signal ②.
- ▶ Unscrew the bulb from the bulb holder.
- ▶ Insert the new bulb into the bulb holder.
- ▶ Refit side turn signal ②.

Replacing rear bulbs

Changing the tail lamp bulbs

Tail lamps without partial LEDs

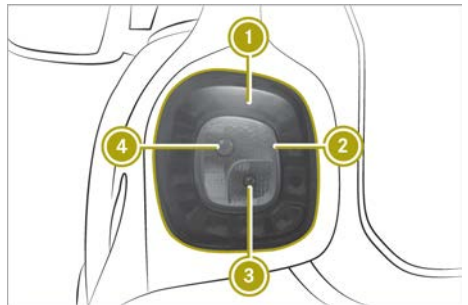

- ① Tail lamp and brake lamp
- ② Rear foglamp
- ③ Reversing lamp
- ④ Turn signals

Tail lamps with partial LEDs

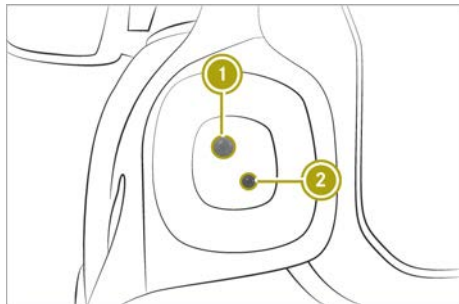

- ① Turn signals
- ② Reversing lamp

Removing the tail lamp cover

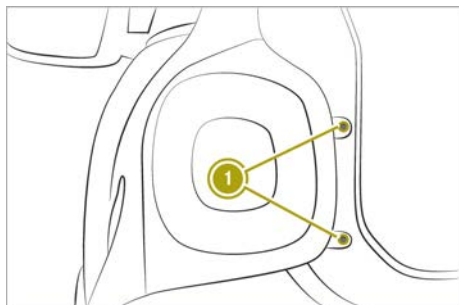

- ▶ Switch off the lights.
- ▶ **smart fortwo coupé:** open the upper and lower tailgate.
- ▶ **smart fortwo cabrio:** open the lower tailgate.
- ▶ **smart fortwo cabrio:** fold the rear soft top up.
- ▶ Loosen screws ①.
- ▶ Remove the tail lamp.
- ▶ Carefully insert a flat tool under the plastic hanger on the tail lamp.
- ▶ Lift the connector and remove it.

Replacing a faulty tail lamp bulb

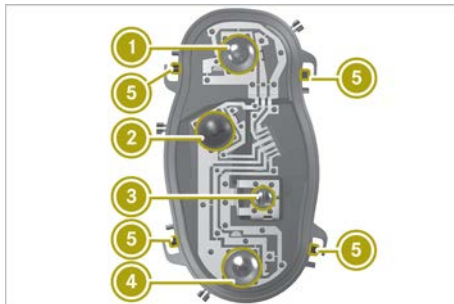

- ① Tail lamp/brake lamp (vehicles without partial LEDs)
- ② Turn signals
- ③ Reversing lamp
- ④ Rear foglamp (vehicles without partial LEDs)

- ▶ Release four tabs ⑤ on the bulb holder.
- ▶ Remove the bulb holder.
- ▶ Pull the faulty bulb out.
- ▶ Insert the new bulb.
- ▶ Refit the bulb holder.
- ▶ Insert the connector.
- ▶ Insert the tail lamp until you hear it engage.
- ▶ Tighten the screws on the tail lamp.

Replacing the licence plate lighting



- ▶ Insert a flat tool into recess ①.
- ▶ Remove the cover from the licence plate lamp.
- ▶ Remove the bulb from the holder.
- ▶ Insert the new bulb into the holder.
- ▶ Insert the lamp lens into the licence plate lamp.

Replacing the interior lighting

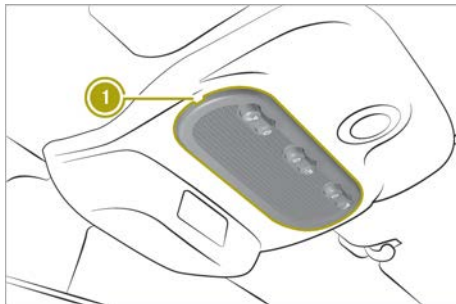

- ▶ Insert a flat tool into the recess.
- ▶ Prise out lamp lens ①.
- ▶ Remove the bulb from the holder.
- ▶ Insert the new bulb into the holder.
- ▶ Refit the lamp lens.

Changing fuses

Please note

⚠ WARNING

If you manipulate, bridge or replace a faulty fuse with a fuse of a higher amperage, the electric cables could be overloaded. This may result in a fire. There is a risk of an accident and injury.

Always replace faulty fuses with specified new fuses of the correct amperage.

! Only use fuses that have been approved for smart vehicles and which have the correct fuse rating for the system concerned. Components or systems could otherwise be damaged.

! Make sure that no moisture can enter the fuse box when the cover is open.

The electrical fuses disconnect defective circuits. If a fuse blows, all the connected components and their functions will fail.

Blown fuses must be replaced with fuses of the same rating, which you can recognise by the colour and fuse rating. The fuse ratings are listed in the fuse allocation chart (▷ page 190).

If new fuses blow, the cause for this must be diagnosed and rectified at a qualified specialist workshop.

Preparing the vehicle to change a fuse

- ▶ Apply the parking brake.
- ▶ Switch off all electrical consumers.
- ▶ Turn key to position 0 in the ignition lock and remove it.
- ▶ Check whether all indicator lamps in the instrument cluster are off.

Changing a fuse (left-hand drive vehicle)

! Do not use a pointed object such as a screwdriver to open the cover in the dashboard. You could damage the dashboard or the cover.

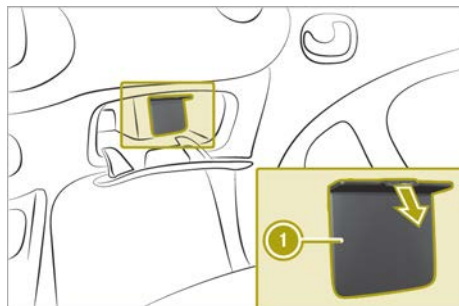

- ▶ Open the front-passenger door.
- ▶ Open the glove compartment.
- ▶ To open: open cover ① in the direction of the arrow.
- ▶ Replace faulty fuse.
- ▶ To close: insert and fold in cover ① until it engages.
- ▶ Close the glove compartment.

Changing a fuse (right-hand drive vehicle)

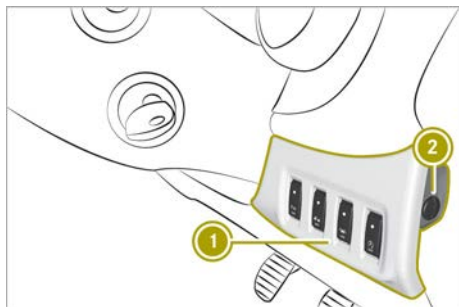

- ▶ Open the driver's door.
- ▶ Turn quick-release fastener ② by 90° using a suitable object.
- ▶ Fold down cover ①.
- ▶ Replace faulty fuse.
- ▶ Close cover ①.
- ▶ Close quick-release fastener ②.

Replacing the key battery

WARNING

Batteries contain toxic and corrosive substances. If batteries are swallowed, it can result in severe health problems. There is a risk of fatal injury.

Keep batteries out of the reach of children. If a battery is swallowed, seek medical attention immediately.

Environmental note



Batteries contain pollutants. It is illegal to dispose of them with the household rubbish. They must be collected separately and disposed of in an environmentally responsible recycling system.



Dispose of batteries in an environmentally responsible manner. Take dis-

charged batteries to a qualified specialist workshop or to a collection point for used batteries.



- ▶ **Fixed keys:** unscrew screw ①.



- ▶ Insert a flat tool, e.g. a coin, into the recess.
- ▶ Turn the tool until the cover of the battery tray opens.

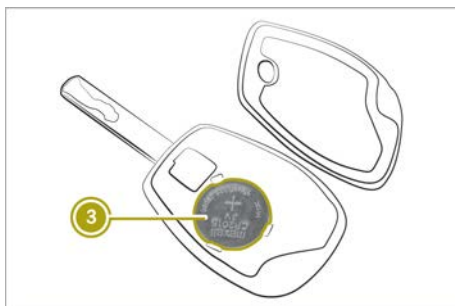

- ▶ Replace battery ③ with the positive terminal facing upwards.
- ▶ Replace the cover on the battery tray and push it closed.

- ▶ **Fixed keys:** tighten screw ①.
- ▶ Check the function of all key buttons.

Opening a door with the emergency release

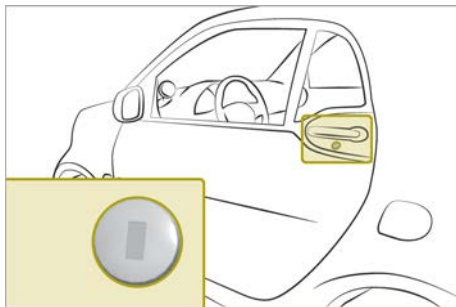

The vehicle can be opened using the emergency release if this is not possible using the remote control key.

If the driver's door is unlocked and opened with the key in the emergency release, the anti-theft alarm system will issue an alarm. To disable the alarm, switch on the ignition.

- ▶ Carefully remove the cover from the emergency release.
- ▶ Insert the key into the emergency release on the driver's door.
- ▶ Turn the key anti-clockwise.
- ▶ Remove the key from the lock.
- ▶ Push the cover into the emergency release until it engages.
- ▶ Open the door.
- ▶ To disable the alarm from the anti-theft alarm system, switch on the ignition.

On right-hand-drive vehicles, the emergency release is located on the front-passenger door.

Locking the doors in an emergency

Locking the doors with the locking button

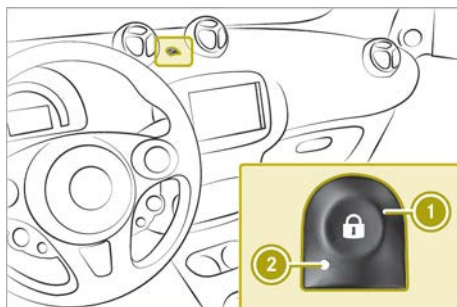

- ▶ Open the driver's door.
- ▶ Close the other doors and the tailgate.
- ▶ Press and hold button ①. An audible locking and unlocking sound can be heard. Wait until the third (locking) sound, before releasing button ①.
- ▶ Leave the vehicle and close the driver's door.

The doors, tailgate and fuel filler cap are locked. The anti-theft alarm system is primed.
- ▶ From the outside, check that the doors, tailgate and fuel filler cap are locked.

Locking the doors with the emergency locking

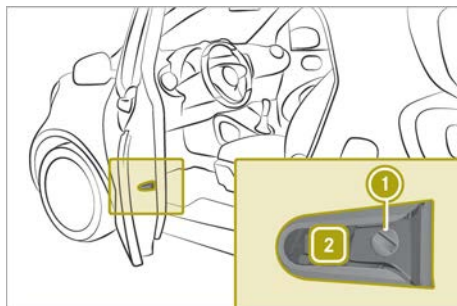

- ▶ Insert the key into slot ① on the left door.
- ▶ Turn the key towards the bonnet as far as it will go to position ②.
- ▶ Close the left door.

- ▶ Repeat the procedure described above on the right door.
- ▶ Check that the doors are locked.
- i** If you lock the vehicle using the emergency locking, the tailgate and fuel filler flap are not locked. The anti-theft alarm system is not primed.

Notes on display messages



The display shows warnings, malfunctions or additional information. A warning tone also sounds with some display messages. Messages from all categories can contain important information that must be observed. Have error messages checked at a Mercedes-Benz Service Centre as soon as possible. If an error message is not followed up with a repair, this can lead to damage that is not covered by the Mercedes-Benz Limited Warranty including injuries or material damage.

Display messages with graphic symbols are simplified in the Owner's Manual and may differ from the symbols in the display.



Colour display: low-priority display messages can be hidden by pressing **OK** on the steering wheel. High-priority messages are shown in red. The display messages are then stored in the message memory and can be called up for as long as the ignition remains switched on. Switching off the ignition clears the message memory.





Locking and unlocking

Problem	Possible causes/consequences and ► Solutions
Key will not lock or unlock the vehicle.	A strong source of radio waves is interfering with the signal. ► Stand closer to the door lock and try to lock/unlock the vehicle again.
	Key battery is low or discharged. ► Unlock the vehicle with the key in the emergency release or lock the vehicle with emergency locking. ► Replace the key battery.
	Key is faulty. To lock: ► Press the locking button and close the door within five seconds. The vehicle still will not lock. ► Lock driver's door using emergency locking. ► Consult a qualified specialist workshop. To unlock: ► Unlock vehicle with the key in the emergency release. ► Consult a qualified specialist workshop.
Key is lost.	► Have the key deactivated or replaced at a qualified specialist workshop. ► Report loss of the key to vehicle insurer.
Side window will not close or will not open or close fully.	Objects are obstructing the window guide. ► Remove objects.

Problem	Possible causes/consequences and ► Solutions
	<p>Side window is not reset.</p> <p> WARNING</p> <p>While closing the side windows, body parts in the closing area could become trapped. There is a risk of injury.</p> <p>When closing make sure that no parts of the body are in the closing area. If somebody becomes trapped, release the switch or press the switch to open the side window again.</p> <ul style="list-style-type: none"> ► Close all doors. ► Turn the key to position 2 in the ignition lock. ► Push switch for closing the window until the window is closed, and then pull the switch for one second. <p>The side window opens again a little way.</p> <ul style="list-style-type: none"> ► Repeat previous step until the window remains closed after releasing the switch.
<p>Fuel filler flap will not open.</p>	<p>Fuel filler flap is not unlocked.</p> <ul style="list-style-type: none"> ► Unlock vehicle. <p>Key battery is low or discharged.</p> <ul style="list-style-type: none"> ► Unlock vehicle using the emergency key element in the emergency release.
<p> Red warning lamp is lit.</p> <p>If the speed exceeds 20 km/h, a warning tone also sounds.</p> <p>Colour display: the display shows an open door/tailgate.</p>	<p>Door or tailgate is open.</p> <ul style="list-style-type: none"> ► Pull over and stop the vehicle, paying attention to road and traffic conditions. ► Close all doors and the tailgate.





Visibility, occupants, airbags





Problem	Possible causes/consequences and ► Solutions
Exterior mirror is not engaged.	The exterior mirror has been moved forwards or backwards by force. ► Carefully move exterior mirror to the correct position.
Windscreen wipers have malfunctioned.	Windscreen wipers are obstructed, e.g. by snow. ► Pull over and stop the vehicle, paying attention to road and traffic conditions. ► Remove key from ignition lock. ► Remove the cause of the obstruction. ► Switch the windscreen wipers on again after 30 seconds. Windscreen wiper drive is malfunctioning. ► Select another wiper speed on the combination switch. ► Consult a qualified specialist workshop.
Windscreen wiper will not stop or always wipes at the same speed.	Combination switch or rain sensor is malfunctioning. ► Pull over and stop the vehicle, paying attention to road and traffic conditions. ► Remove key from ignition lock. ► Insert key in ignition lock, turn to position 1 and start the engine. ► Consult a qualified specialist workshop.
 Red warning lamp lights up for six seconds after starting the engine (certain countries only). Warning tone sounds.	Warning lamp prompts driver and front passenger to fasten their seat belts. ► Fasten seat belts.
 Red warning lamp lights up after starting the engine.	Driver or front passenger has not fastened their seat belt. ► Fasten seat belts.
 Red warning lamp flashes. Warning tone sounds.	Driver or front passenger has not fastened their seat belt and the vehicle is travelling faster than 20 km/h. ► Fasten seat belts.

Problem	Possible causes/consequences and ► Solutions
 Red warning lamp lights up while the engine is running. Colour display: Malfunction Visit workshop appears.	Restraint system is malfunctioning.  WARNING If the restraint system is malfunctioning, restraint system components may be triggered unintentionally or may not deploy as intended during an accident. This may affect the seat belt tensioner or airbag, for example. This poses an increased risk of injury or even fatal injury. Have the restraint system checked and repaired immediately at a qualified specialist workshop.
 Indicator lamp on the overhead control panel lights up.	The front-passenger front airbag has been deactivated (▷ page 35). ► Activate front-passenger front airbag. Front-passenger front airbag has not been deactivated and is malfunctioning. ► Do not use a rearward-facing child restraint system on front-passenger seat. ► Do not allow passengers to travel on the front-passenger seat. ► Consult a qualified specialist workshop.
 Indicator lamp on the overhead control panel lights up.	The front-passenger front airbag is enabled (▷ page 35). The airbag system is operating correctly. ► Do not use a rearward-facing child restraint system on front-passenger seat.
 Indicator lamp on the overhead control panel does not light up if the front-passenger front airbag has been activated manually.	Malfunction in the airbag system. ► Do not allow passengers to travel on the front-passenger seat. ► Consult a qualified specialist workshop.







Engine, brakes, transmission

Problem	Possible causes/consequences and ► Solutions
<p>Engine will not start using the key.</p>	<p>Steering lock is manually locked.</p> <ul style="list-style-type: none"> ► Remove key from ignition lock and then reinsert it into the ignition lock. ► Turn the key. ► Turn steering wheel left and right.
<p>Engine will not start. Starter motor cannot be heard.</p>	<p>On-board voltage is too low.</p> <ul style="list-style-type: none"> ► Switch off electrical consumers that are not required. ► Start the engine. <p>The engine still does not start.</p> <ul style="list-style-type: none"> ► Jump-start the vehicle. <p>The engine will not start despite jump-starting.</p> <ul style="list-style-type: none"> ► Consult a qualified specialist workshop. <hr/> <p>Starter motor has overheated.</p> <ul style="list-style-type: none"> ► Let the starter motor cool down for two minutes. ► Start the engine. <p>The engine still does not start.</p> <ul style="list-style-type: none"> ► Consult a qualified specialist workshop.
<p>Engine will not start. Starter motor can be heard.</p>	<p>Engine electronics or fuel delivery system is malfunctioning.</p> <ul style="list-style-type: none"> ► Switch off the engine. ► Start the engine. <p>Lengthy and frequent starting attempts will drain the battery. The engine will not start after several attempts.</p> <ul style="list-style-type: none"> ► Consult a qualified specialist workshop.
<p>Engine will not start. Starter motor can be heard. The fuel tank gauge is at zero.</p>	<p>Fuel tank is empty.</p> <ul style="list-style-type: none"> ► Refuel the vehicle.
<p>Engine is not running smoothly and is misfiring.</p>	<p>Malfunction in the engine electronics or a mechanical component.</p> <ul style="list-style-type: none"> ► Only depress the accelerator pedal slightly. ► Consult a qualified specialist workshop immediately.

Problem	Possible causes/consequences and ► Solutions
Fuel leaking from vehicle.	Fuel line or fuel tank is faulty.  WARNING Fuel is highly flammable. If you handle fuel incorrectly, there is a risk of fire and explosion. You must avoid fire, naked flames, creating sparks and smoking. Switch off the engine and, if applicable, the auxiliary heating before refuelling. ► Turn the key to position 0 in the ignition lock and remove it. ► Consult a qualified specialist workshop.
 Yellow warning lamp flashes while driving.	Risk of misfiring. Ignition system is malfunctioning. ► Consult a qualified specialist workshop.
 Yellow warning lamp lights up and engine output is reduced. Colour display: Reduced power See Owner's Manual appears.	Engine is running in emergency mode. Ignition system may be malfunctioning. ► Drive on carefully. ► Consult a qualified specialist workshop.
 Yellow warning lamp lights up while the engine is running.	Malfunction in one or more of the following components: <ul style="list-style-type: none"> • Engine management • Exhaust system • Fuel system • Accelerator pedal sensor ► Consult a qualified specialist workshop.
Colour display:  lights up. Low fuel level appears.	The amount of fuel in the tank has reached the reserve range. ► Refuel as soon as possible.







Problem	Possible causes/consequences and ► Solutions
<p> Red warning lamp lights up. Warning tone sounds. Colour display: Stop Switch off engine appears.</p>	<p>The coolant level is too low or the air supply to the engine radiator is restricted. The engine is not being cooled sufficiently and the coolant temperature exceeds 110 °C.</p> <p> WARNING</p> <p>If you open the bonnet while the engine is overheating or while there is a fire in the engine compartment, you could come into contact with hot gases or other leaking service products. There is a danger of injury.</p> <p>Allow an overheating engine to cool down before opening the bonnet. If there is a fire in the engine compartment, leave the bonnet closed and notify the fire brigade.</p> <ul style="list-style-type: none"> ► Stop the vehicle, paying attention to road and traffic conditions, and switch off the engine. ► Leave the vehicle and allow the engine to cool down. ► Make sure that the air supply to the engine radiator is not blocked, e.g. by frozen slush. ► Check the coolant level and top up if necessary. <p>The coolant level is sufficient. The electric engine radiator fan has failed.</p> <ul style="list-style-type: none"> ► Consult a qualified specialist workshop.
<p> Red warning lamp lights up. Warning tone sounds. Stop Switch off motor appears.</p>	<p>The coolant is too hot.</p> <ul style="list-style-type: none"> ► Pull over and stop the vehicle, paying attention to road and traffic conditions. ► Switch off the engine. ► Secure the vehicle against rolling away with the parking brake. ► Consult a qualified specialist workshop. ► Do not tow away the vehicle on its own wheels.
<p> Red warning lamp lights up while the engine is running. Warning tone sounds. Colour display: Stop Switch off engine appears.</p>	<p>Oil pressure is too low.</p> <p> Check the oil level regularly. If there is insufficient oil (oil level is below the MIN mark), there is a risk of engine failure.</p> <ul style="list-style-type: none"> ► Pull over and stop the vehicle, paying attention to road and traffic conditions. ► Switch off the engine. ► Check the engine oil level. ► If necessary, top up the engine oil.

>> Practical advice.







Problem	Possible causes/consequences and ► Solutions
<p> Red warning lamp lights up while the engine is running.</p> <p>Warning tone sounds.</p> <p>Colour display: Check brake fluid level appears.</p>	<p>Brake fluid level is too low.</p> <p> WARNING</p> <p>If the brake fluid level is too low the brake system may fail. There is a risk of an accident.</p> <p>Stop the vehicle in accordance with the traffic conditions. Secure the vehicle by applying the parking brake. Do not drive any further. Consult a qualified specialist workshop immediately and have the brake system repaired.</p> <p>► Consult a qualified specialist workshop.</p>
<p> Red warning lamp lights up while driving.</p> <p>Warning tone sounds.</p> <p>Colour display: Release parking brake appears.</p>	<p>Parking brake is applied.</p> <p>► Release the parking brake.</p>
<p> Yellow warning lamp lights up while driving and when stationary.</p> <p>Colour display: Malfunction See Owner's Manual appears.</p>	<p>The automatic start/stop system is malfunctioning and has been automatically switched off.</p> <p>► Consult a qualified specialist workshop.</p>
<p> Yellow warning lamp lights up when stationary.</p>	<p>Not all conditions for the automatic start/stop system have been met.</p> <p>► Please take note of the conditions for the automatic start/stop system.</p>
<p> Green indicator lamp flashes during automatic engine switch-off.</p> <p>Warning tone sounds.</p> <p>Colour display: When exiting: remove key appears.</p>	<p>Automatic start/stop system has automatically switched off the engine, driver's door has been opened or seat belt has been unfastened.</p> <p>► Close the driver's door.</p> <p>► Fasten seat belts.</p> <p>► Restart the engine.</p> <p>When leaving the vehicle:</p> <p>► Pull over and stop the vehicle, paying attention to road and traffic conditions.</p> <p>► Remove key from ignition lock.</p>







Problem	Possible causes/consequences and ► Solutions
<p>Ⓐ Green indicator lamp flashes while the vehicle is stationary.</p>	<p>Vehicles with manual transmission: the vehicle is at a standstill. No stop preventers are active. The clutch pedal is fully depressed. The engine is not switched off automatically. The flashing indicator lamp is intended to remind you to activate the automatic start/stop system in order to save fuel.</p> <p>► Shift into neutral and release clutch pedal slowly. Engine is switched off automatically.</p>
<p>Ⓐ Green indicator lamp flashes. Colour display: To start engine: operate the clutch appears.</p>	<p>Vehicles with manual transmission: the engine has stalled.</p> <p>► Depress the clutch pedal. The engine starts.</p>
<p>Ⓐ Green indicator lamp flashes. Colour display: To start engine: shift to neutral appears.</p>	<p>Vehicles with manual transmission: the engine has stalled.</p> <p>► Select neutral. The engine starts.</p>
<p>Monochrome display: Ⓐ flashes in the centre of the display. Colour display: To start engine: shift to neutral or depress clutch appears when starting the engine.</p>	<p>Vehicles with manual transmission: gear is selected and the clutch pedal is not fully depressed when starting the engine.</p> <p>► Depress the clutch pedal fully.</p> <p>If the engine fails to start despite the clutch pedal being fully depressed, then the clutch sensor is malfunctioning.</p> <p>► Consult a qualified specialist workshop.</p>
<p>Colour display: To start engine: shift to neutral appears when the engine is started.</p>	<p>Vehicles with manual transmission: clutch sensor is malfunctioning.</p> <p>► Select neutral. ► Consult a qualified specialist workshop.</p>
<p>Monochrome display: Ⓐ flashes in the middle of the display. Colour display: Parking lock malfunction. To park: apply parking brake appears when starting the engine. Warning tone sounds.</p>	<p>Vehicles with automatic transmission: the parking lock is malfunctioning. The vehicle is not secured against rolling away.</p> <p>► Apply the parking brake to park.</p>



Problem	Possible causes/consequences and ► Solutions
<p>Monochrome display:  or  flash alternately in the middle of the display.</p> <p>Colour display: To start engine: shift to P or N appears.</p>	<p>An attempt was made to start the engine with the transmission in position D or R.</p> <p>► Shift to P or N to start.</p>
<p>Monochrome display:  or  /  flash alternately in the middle of the display.</p> <p>Colour display: To start engine: shift to N appears.</p>	<p>Vehicles with automatic transmission: engine switches off while the vehicle is in motion.</p> <p>► Shift to N to start.</p>
<p>Monochrome display:  flashes for 15 seconds in the middle of the display.</p> <p>Colour display: To start engine: apply brake appears.</p>	<p>Vehicles with automatic transmission: an attempt was made to start the engine with the transmission in position N without applying the brake.</p> <p>► Depress the brake pedal.</p>
<p>Monochrome display:  or  /   flash alternately.</p> <p>Warning tone sounds.</p> <p>Colour display: Risk of vehicle rolling away Transmission not in P appears.</p> <p>Warning tone sounds.</p>	<p>Vehicles with automatic transmission: driver's door is open and selector lever is in position R, N or D.</p> <p> WARNING</p> <p>The vehicle may roll away. There is a risk of an accident.</p> <p>► Shift to position P. ► Switch off the engine. ► Close the driver's door completely.</p>
<p>Monochrome display:  lights up.</p> <p>Colour display: Electronics malfunction Visit workshop appears.</p>	<p>Vehicles with manual transmission: electronics are malfunctioning.</p> <p>The system deactivates the automatic start/stop system and cruise control.</p> <p>► Depress clutch pedal fully to start the engine. ► Consult a qualified specialist workshop.</p>
<p> lights up.</p> <p>Colour display: Transmission malfunction Visit workshop appears.</p>	<p>Vehicles with automatic transmission: automatic transmission is malfunctioning.</p> <p>► Consult a qualified specialist workshop.</p>





Problem	Possible causes/consequences and ► Solutions
<p> flashes alternately with the current transmission position P / D / R / N.</p> <p>Colour display: Clutch protection active See Owner's Manual appears.</p>	<p>Vehicles with automatic transmission: other pulling away procedures result in the clutch overheating.</p> <ul style="list-style-type: none"> ► Pull over and stop the vehicle safely as soon as possible, paying attention to road and traffic conditions. ► Secure the vehicle to prevent it from rolling away. ► Wait until the automatic transmission has cooled down and the display message does not reappear after acknowledging it.
<p> flashes alternately with the current transmission position P / D / R / N.</p> <p>Warning tone sounds.</p> <p>Colour display: Transmission overheated See Owner's Manual appears.</p>	<p>Vehicles with automatic transmission: automatic transmission clutch has overheated. You will feel the clutch pedal pulsate.</p> <ul style="list-style-type: none"> ► Avoid pulling away or crawling manoeuvres. If the display message disappears, automatic transmission is available again.
<p>Vehicles with automatic transmission: has faulty gear shifts.</p>	<p>Transmission is losing oil.</p> <ul style="list-style-type: none"> ► Have the transmission checked immediately at a qualified specialist workshop.
<p>Vehicles with automatic transmission: acceleration characteristics are deteriorating.</p> <p>Transmission no longer shifts into all of the gears.</p> <p>Reverse gear can no longer be selected.</p>	<p>Transmission is in emergency mode.</p> <ul style="list-style-type: none"> ► Stop. ► Shift transmission to position P. ► Switch off the engine. ► Wait at least ten seconds. ► Start the engine. ► Shift transmission to position D. ► Have the transmission checked immediately at a qualified specialist workshop.
<p> or  warning lamp flashes for a few seconds after starting the engine.</p> <p>Colour display: Next service in ... km or Service due ... km ago appears.</p>	<p>A service due date is approaching or has already passed:</p> <ul style="list-style-type: none"> •  indicates a minor service. •  indicates a full service. <ul style="list-style-type: none"> ► Consult a qualified specialist workshop.



Driving safety systems





Problem	Possible causes/consequences and ► Solutions
<p> Yellow warning lamp lights up.</p> <p> (USA only) or  (Canada only) Yellow warning lamp lights up.</p> <p>Colour display: System inoperative appears.</p>	<p>ABS is malfunctioning. Other driving systems may be deactivated.</p> <p>If ABS is faulty, there is also a possibility that other driving systems may be unavailable.</p> <p>Observe the information on the ABS warning lamp and display messages which may be shown in the instrument cluster .</p> <p> WARNING</p> <p>If ABS is malfunctioning, the wheels may lock when you brake. This will greatly impair the driver's ability to steer and brake. In addition, further driving safety systems are deactivated. The danger of skidding and having an accident increases.</p> <p>Drive on carefully. Have the ABS checked at a qualified specialist workshop immediately.</p> <ul style="list-style-type: none"> ► Drive on carefully. ► Consult a qualified specialist workshop.
<p> Red warning lamp lights up while the engine is running.</p> <p>Warning tone sounds.</p> <p>Colour display: Brake force distribution inoperative. Stop See Owner's Manual appears.</p>	<p>EBD is malfunctioning. This means that ABS, ESP®, Crosswind Assist and Hill start assist are also unavailable.</p> <p>Other driving systems may be deactivated.</p> <p> WARNING</p> <p>The brake system continues to function normally, but without the functions listed above. The wheels could therefore lock early if you brake hard, for example.</p> <p>The steerability and braking characteristics may be severely affected. The braking distance may increase in emergency braking situations.</p> <p>If ESP® is not operational, ESP® is unable to stabilise the vehicle. The danger of skidding and having an accident increases.</p> <ul style="list-style-type: none"> ► Pull over and stop the vehicle, paying attention to road and traffic conditions. ► Secure the vehicle against rolling away. ► Consult a qualified specialist workshop.

Problem	Possible causes/consequences and ► Solutions
<p> Monochrome display: yellow warning lamp lights up while the engine is running.</p> <p> Colour display: Yellow warning lamp lights up.</p> <p>System inoperative appears.</p>	<p>ESP® is not available due to a malfunction. Other driving systems may be deactivated.</p> <p> WARNING</p> <p>If ESP® is malfunctioning, ESP® is unable to stabilise the vehicle. In addition, other driving safety systems are switched off. This increases the risk of skidding and an accident.</p> <p>Drive on carefully. Have ESP® checked at a qualified specialist workshop.</p> <p>Brake lamps may be inoperative and thus no longer working when braking.</p> <ul style="list-style-type: none"> ► Pull over and stop the vehicle, paying attention to road and traffic conditions. Do not drive on. ► Check that the brake lamps are working. <p>The brake lamps are not working.</p> <ul style="list-style-type: none"> ► Consult a qualified specialist workshop. <p>Brake lamps are working.</p> <ul style="list-style-type: none"> ► Drive on carefully. ► Consult a qualified specialist workshop.
<p> Yellow warning lamp flashes while driving.</p>	<p>ESP® is intervening because there is a risk of skidding or at least one of the wheels is spinning.</p> <ul style="list-style-type: none"> ► Pull away carefully. ► Accelerate carefully whilst driving. ► Adapt your driving style to suit the road and weather conditions.
<p> and  other warning lamps are lit.</p> <p>Colour display: Electronics malfunction Visit workshop appears.</p>	<p>Central vehicle electronics system is malfunctioning.</p> <p>After switching off the engine, it is no longer possible to lock or unlock the doors using the remote control on the key or to start the engine.</p> <ul style="list-style-type: none"> ► Pull over and stop the vehicle, paying attention to road and traffic conditions. ► Consult a qualified specialist workshop.







Problem	Possible causes/consequences and ► Solutions
<p>Colour display:  Hill start assist inoperative appears.</p>	<p>Hill start assist is malfunctioning. Vehicle will not be held automatically when pulling away uphill and may start rolling immediately.</p> <p> WARNING</p> <p>If ESP® is malfunctioning, ESP® is unable to stabilise the vehicle. In addition, other driving safety systems are switched off. This increases the risk of skidding and an accident.</p> <p>Drive on carefully. Have ESP® checked at a qualified specialist workshop.</p> <p>Other driving systems may be deactivated.</p> <p>The brake system functions normally, but without hill start assist.</p> <ul style="list-style-type: none"> ► Drive on carefully. ► Consult a qualified specialist workshop.
<p> Yellow warning lamp lights up while driving.</p> <p>Colour display: Correct tyre pressure appears.</p>	<p>The tyre pressure is too low in at least one of the tyres, or the tyre pressure difference between the wheels is too great.</p> <ul style="list-style-type: none"> ► Check tyre pressure. ► Correct the tyre pressure. ► Restart tyre pressure monitor.







Problem	Possible causes/consequences and ► Solutions
<p> Yellow warning lamp lights up while driving.</p> <p>Colour display: Tyre pressure Caution tyre malfunction appears.</p>	<p>The tyre pressure monitor has detected a significant loss of pressure in at least one of the tyres.</p> <p> WARNING</p> <p>Underinflated or overinflated tyres pose the following risks:</p> <ul style="list-style-type: none"> • the tyres may burst, especially as the load and vehicle speed increase. • the tyres may wear excessively and/or unevenly, which may greatly impair tyre traction. • the driving characteristics, as well as steering and braking, may be greatly impaired. <p>There is a risk of an accident.</p> <p>Observe the recommended tyre pressure and check the tyre pressure of all the tyres:</p> <ul style="list-style-type: none"> • at least every two weeks • when the load changes • before embarking on a longer journey • for changed operating conditions, e.g. off-road driving <p>If necessary, correct the tyre pressure.</p> <ul style="list-style-type: none"> ► Secure the vehicle against rolling away. ► Check tyres visually and, if necessary, follow the instructions for flat tyres. ► Check the tyre pressure and correct it if necessary.
<p> Yellow warning lamp flashes for approximately one minute and then stays lit.</p> <p>Colour display: Tyre pressure monitor inoperative appears.</p>	<p>The tyre pressure monitor is malfunctioning or was not restarted after a wheel change.</p> <p> WARNING</p> <p>If you correct the tyre pressure without recalibrating the Run Flat Indicator, the system cannot issue a warning about a defective tyre in time. In the event of tyre pressure loss, the driving characteristics and the steering and braking may be greatly impaired. There is a risk of an accident.</p> <p>If you correct the tyre pressure, you must recalibrate the Run Flat Indicator.</p> <ul style="list-style-type: none"> ► Restart tyre pressure monitor. <p>The display message continues to be displayed.</p> <ul style="list-style-type: none"> ► Drive on carefully. ► Consult a qualified specialist workshop.



Problem	Possible causes/consequences and ► Solutions
<p> Yellow warning lamp flashes for approximately 60 seconds and then stays lit.</p> <p>Colour display: Tyre pressure monitor inoperative wheel sensors missing appears.</p>	<p>There is no signal from the tyre pressure sensor of one or more wheels.</p> <p> WARNING</p> <p>Risk of accident due to undetected tyre pressure losses. The system is possibly unable to recognise or register low tyre pressure.</p> <p>► Consult a qualified specialist workshop.</p> <hr/> <p>Wheels have unsuitable tyre pressure sensors.</p> <p>► Fit wheels with suitable tyre pressure sensors.</p>

Problem	Possible causes/consequences and ► Solutions
<p> Red warning lamp is lit.</p> <p> Yellow warning lamps light up while the engine is running.</p> <p>Warning tone sounds.</p> <p>Colour display: Electronics malfunction Stop See Owner's Manual appears.</p>	<p>The following systems are malfunctioning:</p> <ul style="list-style-type: none"> • ABS (anti-lock braking system) • ESP® (Electronic Stability Program) • Crosswind Assist • Hill start assist <p>Further driving systems could be switched off automatically.</p> <p> WARNING</p> <p>The risk of skidding and having an accident increases due to malfunctioning driving safety systems.</p> <p>The brake system functions normally, but without the systems listed. The wheels could therefore lock up if you brake hard, for example.</p> <p>This will greatly impair the ability to steer and brake. The braking distance may increase in emergency braking situations.</p> <p>► Pull over and stop the vehicle, paying attention to road and traffic conditions.</p> <p>► Consult a qualified specialist workshop.</p>
<p> Yellow warning lamp lights up while the engine is running.</p> <p>Colour display: Steering malfunction See Owner's Manual</p>	<p>Power assistance may be malfunctioning, making steering difficult.</p> <p> WARNING</p> <p>If the steering fluid level is too low, the power steering may fail. You will then need to use considerably more force to steer. There is a risk of an accident.</p> <p>Stop the vehicle immediately, paying attention to road and traffic conditions, and secure the vehicle using the parking brake. Check whether you are able to apply the extra force required to steer.</p> <p>Have the power steering checked and repaired immediately at a qualified specialist workshop.</p> <ul style="list-style-type: none"> • If you are able to steer safely, drive on carefully to a qualified specialist workshop. • If you are not able to steer safely, do not continue driving. Contact a qualified specialist workshop.



Driver assistance systems





Problem	Possible causes/consequences and ► Solutions
 Red warning lamp is lit. Warning tone sounds.	Forward collision warning detects obstacle on the road. ► Pay careful attention to the road and traffic conditions and be ready to brake.
 Red warning lamp is lit.	Distance to the vehicle in front is too short for the current speed. ► Increase the distance.
 Yellow warning lamp lights up while driving. Colour display: Distance warning inoperative or Electronics malfunction Visit workshop appears.	The sensors in the radiator trim are dirty. ► Clean the sensors. Environmental influences or error sources outside the system are temporarily interfering with the forward collision warning. Possible causes: <ul style="list-style-type: none"> • Heavy rain or snow. • Operating temperature is too high. • On-board voltage is too low. Forward collision warning is operational again when the causes listed no longer apply. Warning lamp remains lit. ► Pull over and stop the vehicle, paying attention to road and traffic conditions. ► Clean the sensors. ► Restart the engine. Warning lamp still remains lit. ► Consult a qualified specialist workshop.
 and  and other warning lamps are lit.	Central vehicle electronics system is malfunctioning. After switching off the engine, it is no longer possible to lock or unlock the doors using the remote control on the key or to start the engine. Do the following: <ul style="list-style-type: none"> ► Pull over and stop the vehicle, paying attention to road and traffic conditions. ► Consult a qualified specialist workshop.
 flashes for approximately 3 seconds. Warning tone sounds. Colour display: Lane Keeping Assist inoperative appears.	Windscreen is dirty in the camera's field of vision. ► Pull over and stop the vehicle, paying attention to road and traffic conditions. ► Clean the windscreen.

Problem	Possible causes/consequences and ► Solutions
	<p>Environmental influences are interfering with Lane Keeping Assist. Possible causes:</p> <ul style="list-style-type: none"> • Heavy rain or snow or thick fog is impairing visibility. • The sun is low in the sky and shining directly onto the sensor. • Lane markings cannot be detected. <p>Lane Keeping Assist is automatically operational again when the causes listed no longer apply.</p> <p>If the windscreen is clean and the causes listed do not apply, then the electronics are malfunctioning.</p> <p>System electronics are faulty.</p> <p>► Consult a qualified specialist workshop.</p>
<p> flashes for a maximum of 5 seconds.</p> <p>Colour display:  green warning lamp flashes for a maximum of five seconds.</p> <p>Warning tone sounds.</p>	<p>A lane boundary marking was crossed without using the turn signal.</p> <ul style="list-style-type: none"> ► Stay inside the lane boundary markings. ► Use indicator before changing lanes.
<p> flashes for approximately 10 seconds.</p> <p>Warning tone sounds.</p> <p>Colour display:  Cruise control inoperative appears.</p>	<p>Cruise control is malfunctioning and deactivates automatically.</p> <ul style="list-style-type: none"> ► Consult a qualified specialist workshop.
<p> flashes for approximately 10 seconds.  and other warning lamps are also lit.</p> <p>Warning tone sounds.</p> <p>Colour display: Electronics malfunction Visit workshop appears.</p>	<p>Central vehicle electronics system and cruise control are malfunctioning. After switching off the engine, it is no longer possible to lock or unlock the doors using the remote control on the key or to start the engine.</p> <ul style="list-style-type: none"> ► Pull over and stop the vehicle immediately, paying attention to road and traffic conditions. ► Consult a qualified specialist workshop.
<p> lights up.</p> <p>Speed display flashes.</p> <p>Warning tone sounds.</p>	<p>Vehicle is exceeding the set limit speed.</p> <ul style="list-style-type: none"> ► Brake the vehicle, paying attention to road and traffic conditions.

Problem	Possible causes/consequences and ► Solutions
<p> flashes for approximately 10 seconds.</p> <p>Warning tone sounds.</p> <p>Colour display: Lim-iter inoperative appears.</p>	<p>Speed limiter is malfunctioning and deactivates automatically.</p> <p>► Consult a qualified specialist workshop.</p>
<p> Warning lamp flashes for a minute or lights up continuously.</p> <p>Colour display: Black ice warning appears.</p>	<p>The outside temperature has fallen to or below 3 °C. There is a risk of black ice.</p> <p>► Adapt your driving style and speed to suit the weather conditions.</p>

Battery, lights, heating

Problem	Possible causes/consequences and ► Solutions
<p>Rear window heating or seat heating switches off automatically or cannot be switched on.</p>	<p>Battery is not sufficiently charged.</p> <p>► Switch off electrical consumers that are not required.</p>
<p> Red warning lamp lights up when the vehicle is ready to start.</p> <p>Warning tone sounds.</p> <p>Colour display: Stop See Owner's Manual appears.</p>	<p>Possible causes:</p> <ul style="list-style-type: none"> • Alternator is faulty. • Battery is faulty. • V-belt is torn. • Electronics are malfunctioning. <p>► Do not continue driving.</p> <p>► Pull over and stop the vehicle, paying attention to road and traffic conditions.</p> <p>► Switch off the engine.</p> <p>► Consult a qualified specialist workshop.</p>
<p>Colour display:  Warning lamp lights up.</p> <p>Malfunction Visit workshop appears.</p>	<p>Battery monitoring is malfunctioning.</p> <p>► Consult a qualified specialist workshop.</p>
<p>Monochrome display:  Warning lamp lights up.</p>	<p>Dipped beam is on continuously. Main beam cannot be activated.</p> <p>► Switch off the engine.</p> <p>► Start the engine.</p>

Problem	Possible causes/consequences and ► Solutions
	<p>If, after that, the warning lamp is still lit up: Brake lamps are inoperative. The bulb or LED is faulty.</p> <p> WARNING</p> <p>Risk of accident due to faulty brake lamps. The brake lamps are faulty and no longer alert other road users when braking.</p> <ul style="list-style-type: none"> ► Pull over and stop the vehicle, paying attention to road and traffic conditions. ► Consult a qualified specialist workshop. <hr/> <p>If, after that, the warning lamp is still lit up: Rain/light sensor is malfunctioning.</p> <ul style="list-style-type: none"> ► Manually adjust exterior lighting. ► Manually adjust windscreen wipers. ► Consult a qualified specialist workshop.
<p>Colour display:  Warning lamp lights up. Malfunction See Owner's Manual appears.</p>	<p>Dipped beam is on continuously. Main beam cannot be activated.</p> <ul style="list-style-type: none"> ► Switch off the engine. ► Restart the engine. <hr/> <p>If the message continues to be displayed: Rain/light sensor is malfunctioning.</p> <ul style="list-style-type: none"> ► Manually adjust exterior lighting. ► Manually adjust windscreen wipers. ► Consult a qualified specialist workshop.
<p>Colour display:  Warning lamp lights up. Brake lamps inoperative appears.</p>	<p>Brake lamps are inoperative. The bulb or LED is faulty.</p> <p> WARNING</p> <p>Risk of accident due to faulty brake lamps. The brake lamps are faulty and no longer alert other road users when braking.</p> <ul style="list-style-type: none"> ► Pull over and stop the vehicle, paying attention to road and traffic conditions. ► Consult a qualified specialist workshop.
<p>Colour display: Switch off lights appears. Warning tone sounds.</p>	<p>Lights are still switched on when you leave the vehicle.</p> <ul style="list-style-type: none"> ► Turn control knob for the lights to AUTO or 0.

smart Audio-System and smart Media-System

Bluetooth® connection

Problem	Possible causes/consequences and ► Solutions
Bluetooth® connection cannot be established between the smart Audio-System or smart Media-System and mobile phone.	<ul style="list-style-type: none"> ► Ascertain whether the mobile phone is compatible with the system. Information about compatible mobile phones: www.smart.com/connect ► Check the security settings on your mobile phone. ► Check that the Bluetooth® function is enabled on the smart Audio-System or smart Media-system and on your mobile phone. ► Start the device search on the smart Audio-System or smart Media-System and on the mobile phone.

The navigation system in the smart Media-System

Problem	Possible causes/consequences and ► Solutions
No map is displayed in the navigation system.	<p>The SD card with the map data is missing or damaged.</p> <ul style="list-style-type: none"> ► Check to see that the SD card is inserted.
Position of the vehicle in the navigation system does not match the vehicle's actual position. GPS symbol on the display is grey or yellow.	<p>GPS reception is poor.</p> <ul style="list-style-type: none"> ► Drive the vehicle to another position where GPS reception is better.
The road's course in the navigation system no longer coincides with the actual road.	<p>The map data is out of date.</p> <ul style="list-style-type: none"> ► Update the map data.
Navigation system does not display any traffic information.	<p>Route guidance has not been started.</p> <ul style="list-style-type: none"> ► Select a destination and start navigation. <p>HD Traffic is not available or the subscription for HD Traffic has expired.</p> <ul style="list-style-type: none"> ► Check whether HD Traffic is available for the country you are in or upgrade the subscription for HD Traffic.
There are no navigation messages during route guidance.	<p>The road's course is not detected. The map data may be out of date.</p> <ul style="list-style-type: none"> ► Check if route guidance has started. ► If not, select a destination and start navigation. <p>Navigation messages are switched off.</p> <ul style="list-style-type: none"> ► Switch on navigation messages.

Voice control system in the smart Media-System

Problem	Possible causes/consequences and ► Solutions
The voice control system does not understand voice commands.	Interval for entering voice commands has been exceeded. ► Press the  button on the multifunction steering wheel.
	Voice commands have not been given from the driver's seat. ► Issue voice commands from the driver's seat.
	Noise from the blower or wind noise are interfering with voice commands. ► Avoid interfering noises.
	Voice commands have not been given clearly. ► Say voice commands clearly.
	Voice command is unknown. ► Say the command "Help". A list of possible voice commands appears.

Obtaining technical data

Information on technical data:
www.smart.de

The technical data was determined in accordance with EC Directives. All data applies to the vehicle's standard equipment. Differences will be present in the case of vehicles with optional equipment. Further information is available from any smart Centre.

Reading out vehicle data

Useful information

The heights specified vary as a result of:

- Tyres
- Load
- Condition of the suspension
- Optional equipment

Optional equipment reduces the maximum payload.

Only for certain countries: you can find vehicle-specific vehicle data in the COC documents (EU CERTIFICATE OF CONFORMITY). These documents are delivered with your vehicle.

Vehicle identification plate

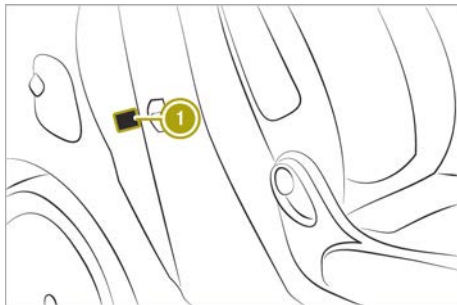

① Vehicle identification plate position

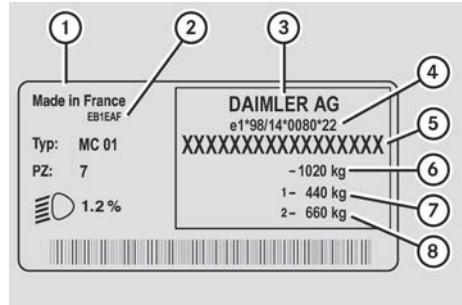

- ① Vehicle identification plate
- ② Paint code
- ③ Vehicle manufacturer
- ④ EU type approval number
- ⑤ Vehicle identification number (VIN)
- ⑥ Maximum permissible gross vehicle weight
- ⑦ Maximum permissible front axle load
- ⑧ Maximum permissible rear axle load

i The data shown on the vehicle identification plate is example data. This data is different for every vehicle and can deviate from the data shown here. The data applicable to the vehicle is found on the vehicle's identification plate.

Dimensions and weight

Missing technical data was not available at the time of publication.

Dimensions and weight (smart fortwo coupé)

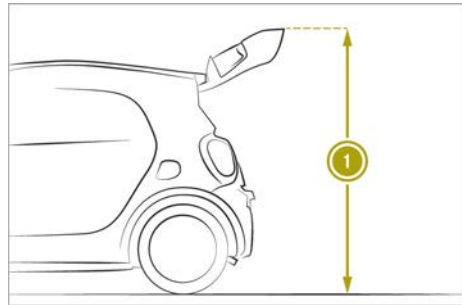

Specifications	Dimensions, weight and volumes
Opening height ①	1855 mm
Vehicle length	2695 mm
Vehicle width including exterior mirrors	1893 mm
Vehicle width excluding exterior mirrors	1663 mm
Vehicle width excluding exterior mirrors for vehicles equipped with wheel trims	
Vehicle height	1555 mm
Wheelbase	1873 mm
Maximum boot load	75 kg
Maximum tailgate load	
Tank capacity	Total: 28.0 l Reserve: 5.0 l

Specifications (BRABUS)	Dimensions, weight and volumes
Opening height ①	
Vehicle length	2740 mm
Vehicle width including exterior mirrors	1893 mm
Vehicle width excluding exterior mirrors	1663 mm
Vehicle width excluding exterior mirrors for vehicles equipped with wheel trims	
Vehicle height	1543 mm
Wheelbase	1873 mm
Maximum boot load	
Maximum tailgate load	
Tank capacity	Total: 35.0 l Reserve: 5.0 l

Dimensions and weight (smart fortwo cabrio)

Specifications	Dimensions, weight and volumes
Vehicle length	2695 mm
Vehicle width including exterior mirrors	1893 mm
Vehicle width excluding exterior mirrors	1663 mm
Vehicle width excluding exterior mirrors for vehicles equipped with wheel trims	
Vehicle height	1553 mm
Wheelbase	1873 mm
Maximum boot load	75 kg
Maximum tailgate load without side bars	
Maximum tailgate load with sidebars	
Tank capacity	Total: 28.0 l Reserve: 5.0 l

Specifications (BRABUS)	Dimensions, weight and volumes
Vehicle length	2740 mm
Vehicle width including exterior mirrors	1893 mm
Vehicle width excluding exterior mirrors	1663 mm
Vehicle width excluding exterior mirrors for vehicles equipped with wheel trims	
Vehicle height	1543 mm
Wheelbase	1873 mm
Maximum boot load	
Maximum tailgate load without side bars	

Specifications (BRABUS)	Dimensions, weight and volumes
Maximum tailgate load with sidebars	
Tank capacity	Total: 35.0 l Reserve: 5.0 l

Service products

The following table lists all technical data for the service products of the vehicle. Further information on service products: <http://bevo.mercedes-benz.com> and in any smart centre.

Service products	Specifications
Fuel (▷ page 67)	Unleaded petrol, with at least 95 RON that conforms to the European standard EN 228, as an alternative: unleaded petrol with 91 RON/82 MON BRABUS: Super unleaded, with at least 98 ROZ/88 MOZ that conforms to the European standard EN 228, as an alternative: unleaded petrol with 95 ROZ/85 MOZ
Engine oil (▷ page 133)	229.51, 229.53, as an alternative: 229.1 and 229.3 or ACEA A3
Corrosion inhibitor/antifreeze (▷ page 134)	Recommended: G40
Windscreen washer fluid (▷ page 134)	Temperatures above freezing point: mixing ratio of 1:100 MB SummerFit to water Temperatures below freezing point: for the correct mixing ratio of MB WinterFit and water, please observe the information on the antifreeze container.

Bulb types

The following table lists the correct bulb types of the vehicle:

Bulb	Type
Dipped-beam/main-beam headlamps	H4 60/55 W
Front foglamps	H 16
Turn signals	PY 21 W
Side turn signal lamps	WY 5 W
Licence plate lighting	W 5 W
Interior lighting	W 5 W

Tail lamps

Bulb	Type
Tail lamp and brake lamp	P21 5 W
Rear foglamp	P21 W
Reversing lamp	W 16 W
Turn signals	PY 21 W

Fuse allocation

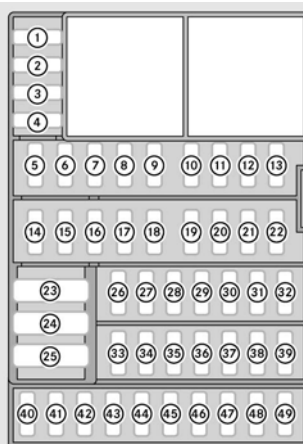

No.	Consumer	Current	Colour coding
1	Starter motor	5 A	Brown
2	Power steering control unit	5 A	Brown
3	Multifunction lever	5 A	Brown
4	Airbag	5 A	Brown
5	Transmission control unit	25 A	Cyan
6	Instrument cluster	10 A	Red
7	Horn, alarm system	15 A	Blue
8	Power supply control unit	10 A	Red
9	Power supply control unit	10 A	Red
10	Central control unit	20 A	Yellow
11	Central control unit	15 A	Blue
12	Central control unit	10 A	Red
13	Central control unit	15 A	Blue
14	Power windows (automatic reversing feature)	30 A	Green
15	esp®, transmission control unit	5 A	Brown
16	Interior lighting	10 A	Red
17	Immobiliser	3 A	Violet
18	Electrical exterior mirror	5 A	Brown
19	Brake lamps	10 A	Red
20	Cruise control, radio, belt warning	15 A	Blue
21	Central control unit, fuel pump, injection	15 A	Blue

No.	Consumer	Current	Colour coding
22	Rear window wiper	15 A	Blue
23	Only for eDrive: power supply control unit	40 A	Orange
24		5 A	Brown
25	Power supply control unit	30 A	Green
26	Radio	20 A	Yellow
27	Daytime driving lamps	5 A	Brown
28	12 V socket, cigarette lighter	15 A	Blue
29	Power supply control unit	5 A	Brown
30	Forward collision warning	15 A	Blue
31	Rear fog lamps	-	-
32	Radio, central control unit	15 A	Blue
33	Tail lamps, front fog lamps, hazard warning lamp button, locking button, headlamp range control, power windows, licence plate lighting, radio, control unit for air-conditioning system, cruise control, limiter, parking aid button, program selector button, tailgate release, Lane Keeping Assist camera, automatic start/stop system button	25 A	Cyan
34	Power supply control unit	25 A	Cyan
35	Headlamps, daytime driving lamps	25 A	Cyan

No	Consumer	Current	Colour coding
36	Left-hand dipped beam, central control unit	10 A	Red
37	Right-hand dipped beam	10 A	Red
38	Left-hand dipped beam, central control unit	10 A	Red
39	-	-	-
40	-	-	-
41	-	-	-
42	-	-	-
43	Exterior mirror heating	5 A	Brown
44	Automatic reversing feature	25 A	Cyan
45	Power supply control unit	25 A	Cyan
46	Radio amplifier	20 A	Yellow
47	-	-	-
48	-	-	-
49	-	-	-

Radio type approvals for the tyre pressure monitors

Country	Radio type approval number
Argentina	MW2433A H-12337 GG4 H-12338
Brazil	2770-12-8001 Model: MW2433A 0381-13-8001 Model: GG4

Country	Radio type approval number
Abu Dhabi Dubai	TRA, Registered-NO ER0092100/12 TRA, Registered-NO ER0099792/12 TRA, Registered-NO ER0076990/11 Dealer-NO: DA0047074/10
Jordan	Model: Gen Alpha Wal 2 TPMS transmitter Type Approval Number: TRC/LPD/2012/114 Model: Gen Gamma Gen 4 433.92 MHz. Type Approval Number: TRC/LPD/2012/190 Model: Corax 3 MRXMC34MA4 Type Approval Number: TRC/LPD/2011/158 Type Number: LPD
Morocco	MR7319 ANRT 2012/ 11/07/2012 MR7672 ANRT 2012/ 23/11/2012 MR6706 ANRT 2011
Moldova	1024
Philippines	No: ESD-1206394C No: ESD-1306871C
Serbia	И 011 12
Singapore	Compliance with IDA Standard DA- 103365
South Africa	TA-2012/719 TA-2012/1540 TA-2011/1370

Retrofitting two-way radios and mobile phones (RF transmitters)

WARNING

If RF transmitters are tampered with or not properly retrofitted, the electromagnetic radiation they emit can interfere with the vehicle electronics. This may jeopardise the operational safety of the vehicle. There is a risk of an accident.

You should have all work on electrical and electronic components carried out at a qualified specialist workshop.

⚠ WARNING

If you operate RF transmitters incorrectly in the vehicle, the electromagnetic radiation could interfere with the vehicle electronics, e.g.:

- if the RF transmitter is not connected to an exterior aerial
- the exterior aerial has been fitted incorrectly or is not a low-reflection type

This could jeopardise the operating safety of the vehicle. There is a risk of an accident. Have the low-reflection exterior aerial fitted at a qualified specialist workshop. When operating RF transmitters in the vehicle, always connect them to the low-reflection exterior aerial.

! Only have work carried out on the engine electronics and its associated parts, such as control units, sensors, actuating components and connector leads, at a qualified specialist workshop. Vehicle components may otherwise wear more quickly and the vehicle's operating permit may be invalidated.

! The operating permit may be invalidated if the instructions for installation and use of RF transmitters are not observed.

In particular, the following conditions must be complied with:

- only approved wavebands may be used.
- observe the maximum permissible output in these wavebands.
- only approved aerial positions may be used.

Excessive levels of electromagnetic radiation can cause damage to health. The use of an exterior aerial takes into consideration the scientific discussion surrounding the possible health risk posed by electromagnetic fields.

The following aerial positions may be used if RF transmitters have been properly installed:

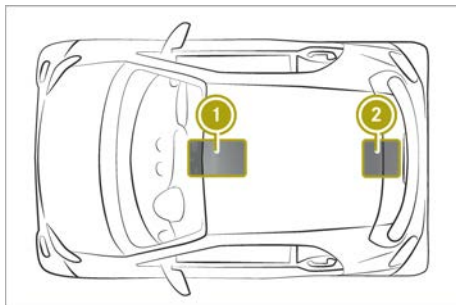

- ① Front roof area
- ② Rear roof area

Use Technical Specification ISO/TS 21609 (Road Vehicles – EMC guidelines for installation of aftermarket radio frequency transmitting equipment) when retrofitting RF (radio frequency) transmitters. Comply with the legal requirements for add-on parts.

If your vehicle has fittings for two-way radio equipment, use the power supply and aerial connections intended for use in the basic wiring. Be sure to observe the manufacturer's additional instructions during installation. Deviations with respect to wavebands, maximum transmission outputs or aerial positions must be approved by smart.

The maximum transmission output (PEAK) at the base of the aerial must not exceed the following values:

Waveband	Maximum transmission output
Tetra 380 - 410 MHz	20 W
Mobile communications generation 2G/3G/4G	6 W

The following can be used in the vehicle without restrictions:

- RF transmitters with a maximum transmission output of up to 100 mW
- Mobile phones (2G/3G/4G)

There are no restrictions when positioning the aerial on the outside of the vehicle for the following wavebands:

- Tetra
- Mobile communications (2G/3G/4G)

Publication details

Internet

Further information about smart vehicles and about Daimler AG can be found on the following websites:

<http://www.smart.com>

<http://www.daimler.com>

Editorial office

You are welcome to forward any queries or suggestions you may have regarding this Owner's Manual to the technical documentation team at the following address:

Daimler AG, HPC: CAC, Customer Service,
70546 Stuttgart, Germany

©Daimler AG: not to be reprinted, translated or otherwise reproduced, in whole or in part, without written permission from Daimler AG.

Vehicle manufacturer

Daimler AG
Mercedesstraße 137
70327 Stuttgart
Germany

Order no. 6522 0175 02
Part no. 453 584 89 05
Edition AJ2016-1a



Other ManualsLib Projects



www.manualslib.com



www.manualslib.de



www.manualslib.es



www.manualslib.fr



www.manualslib.nl



www.manualslib.mx



www.manualslib.tech 30+ Languages